

2024  
2025



*Universal Products*

*Global Partnerships*

*Localized Support*

# Tools that matter for your work

**Cordless | Pneumatic Solutions**

CONSTRUCTION | CARPENTRY | AUTO MAINTENANCE | METAL WORK

# **WARNING :**

- All the pneumatic tools should only be used as hand operated tools.
- They are powered by compressed air and are not insulated against electric shock.
- Always turn off the air supply and disconnect the air hose before changing or replacing any inserted tool and accessory.
- Before using these tools, make sure that all couplings and plugs are securely fastened. Air hoses which are under pressure may lash out when disconnecting, that can lead to serious injury!
- High sound levels may cause hearing damage.
- Always wear hearing protection when operating this tool.
- Wearing eye/face protection can reduce the danger of high-speed materials being emitted from the tool.
- Make sure that the direction of the spark generated from the cutting wheel grinding wheel or shank stone is properly directed so as to not create a hazard..
- Always wear gloves to reduce risk
- User must wear proper clothing.
- Loose clothing, long hair, stings, straps, belts and jewelry should not be worn when operating this tool.
- Long periods of prolong use will cause fatigue.
- Periodic breaks are recommended for user safety.
- It is recommended to stop operating the tool whenever discomfort, tingling or pain occurs during use.
- Make sure there is no gas or combustible material stored near the tool when servicing, changing insert tools, or storage.
- Wearing proper breathing protection to avoid inhale dust or handling debris from working process, which can be harmful to the health.



**AUTHENTIC POWER**

# LEVEL IDENTIFICATION

## LEVEL

The air tools in this section have been categorized into three distinctive levels for user convenience (for reference only).



### Efficiency / Performance

Easy to use to handle tasks quickly, these tools embody efficiency and performance.



### Strength

Tools provide high torque force, superior grinding power and high cutting energy.



### Endurance

Built to last, product longevity and low failure rate are characteristics associated with these tools.

## APPLICATION

Application icons have been designed to provide visual references that suggest industry specific features or usability. These application icons are for reference only.



Automotive



Industry



Shipbuilding



Motorcycle



Agriculture



Aviation

## **CONTENT**

- 04 - NEW PRODUCT
- 10 - AIR IMPACT WRENCH
- 20 - AIR RATCHET WRENCH
- 24 - AIR DIE GRINDER
- 28 - MICRO AIR DIE GRINDER
- 29 - AIR ANGLE GRINDER
- 32 - AIR BELT SANDER
- 33 - AIR SANDER
- 36 - AIR SQUARE SANDER
- 37 - AIR PISTOL POLISHER
- 38 - AIR CUTTING TOOLS
- 42 - AIR DRILL
- 48 - AIR SCREWDRIVER
- 53 - SPRING BALANCER
- 54 - AIR HAMMER
- 57 - AIR HYDRAULIC RIVETER
- 60 - RIVETER ADAPTOR/RIVET NUT ADAPTOR
- 61 - AIR NAILER / AIR STAPLER
- 63 - AIR GREASE GUN
- 64 - AIR BLOW GUN
- 65 - AUTO REPAIR TOOL
- 72 - SANDBLASTING GUN
- 73 - FILTER REGULATOR LUBRICATOR
- 75 - AIR HOSE REEL
- 76 - TORQUE WRENCH
- 79 - DIGITAL TORQUE WRENCH
- 82 - IMPACT SOCKET
- 101 - AFTER MARKET SUPPORT
- 103 - DISPLAY CASE
- 104 - ACCESSORIES
- 112 - AIR ADAPTOR / QUICK COUPLINGS
- 114 - POWER BIT
- 116 - MERCHANDISE
- 118 - CATALOGING INFORMATION
- 123 - ALPHABETIC INDEX
- 128 - CORDLESS TOOLS

# NEW PRODUCT



**BRUSHLESS**

## DRH-101 **BRUSHLESS** CORDLESS ROTARY HAMMER



## DRH-101A **BRUSHLESS** CORDLESS ROTARY HAMMER



| Item No. | Chuck Type | Impact Energy<br>J | Free Speed<br>R.P.M | Blows Per Minute<br>B.P.M | Max. Drilling Capacity<br>mm |       |          | Net Weight |     |
|----------|------------|--------------------|---------------------|---------------------------|------------------------------|-------|----------|------------|-----|
|          |            |                    |                     |                           | Wood                         | steel | Concrete | LBS        | kg  |
| DRH-101  | SDS Plus   | 2.6                | 1150                | 5100                      | 30                           | 13    | 26       | 6.17       | 2.8 |

## DOM-101 **BRUSHLESS** CORDLESS OSCILLATING MULTIT-TOOL



## DOM-101A **BRUSHLESS** CORDLESS OSCILLATING MULTIT-TOOL



| Item No. | Minimum Oscillations<br>per minute | Maximum Oscillations<br>per minute | Oscillation Angle<br>B.P.M | Tool Length<br>mm | Net Weight |      |
|----------|------------------------------------|------------------------------------|----------------------------|-------------------|------------|------|
|          |                                    |                                    |                            |                   | LBS        | kg   |
| DOM-101  | 11000                              | 18000                              | 1.8°                       | 320               | 2.29       | 1.04 |

**DR-102** *BRUSHLESS*  
CORDLESS RIVET GUN



**DR-102A** *BRUSHLESS*  
CORDLESS RIVET GUN



| Item No. | Traction Power | Stroke Length | Capacity | Battery   | Rating Voltage | Completely Charged | Tool Length | Weight |
|----------|----------------|---------------|----------|-----------|----------------|--------------------|-------------|--------|
|          | lb-f / kg-f    | mm            | mm       | Li-ion Ah | V              | V                  | mm          | kg     |
|          |                |               |          |           |                |                    |             |        |
| DR-102   | 4496 / 2040    | 27            | 2.4-6.4  | 5.0       | 18             | 20                 | 320         | 1.63   |

**DGG-102**  
CORDLESS GREASE GUN



**DGG-102A**  
CORDLESS GREASE GUN



| Item No. | Working Pressure | Grease Output | Capacity | Battery   | Rating voltage | Completely charged | Net Weight |     |
|----------|------------------|---------------|----------|-----------|----------------|--------------------|------------|-----|
|          | PSI              | ml            | g        | Li-ion Ah | V              | V                  | LBS        | kg  |
|          |                  |               |          |           |                |                    |            |     |
| DGG-102  | 7000             | 94.6          | 400      | 5.0       | 18             | 20                 | 5.3        | 2.4 |

**DHG-101**  
CORDLESS HEAT GUN



| Item No. | Max Temperature | Airflow | Battery   | Rating voltage | Completely charged | Net Weight |      |
|----------|-----------------|---------|-----------|----------------|--------------------|------------|------|
|          |                 | L/min   | Li-ion Ah | V              | V                  | LBS        | kg   |
|          |                 |         |           |                |                    |            |      |
| DHG-101  | 550 °c          | 200     | 5.0       | 18             | 20                 | 1.38       | 0.63 |

NEW PRODUCT

# NEW PRODUCT

## DW-404 *BRUSHLESS* CORDLESS IMPACT WRENCH



## DW-404A/DW-404K *BRUSHLESS* CORDLESS IMPACT WRENCH



DW-404A

DW-404K



| Item No. | Square Drive<br>Inch (mm) | Bolt Capacity | Max Torque<br>FT-LB Nm | No Load Speed<br>R.P.M     | Impact Rate<br>ipm          | Rating Voltage<br>V | Completely Charged<br>V | Net Weight<br>kg |
|----------|---------------------------|---------------|------------------------|----------------------------|-----------------------------|---------------------|-------------------------|------------------|
| DW-404   | 1/2"(12.7)                | M6-M16        | 660 900                | 0-900/0-1400/0-1800/0-2200 | 0-1150/0-1700/0-2300/0-2500 | 18                  | 20                      | 1.16             |

## DW-406 *BRUSHLESS* CORDLESS IMPACT WRENCH



## DW-406A *BRUSHLESS* CORDLESS IMPACT WRENCH



| Item No. | Square Drive<br>Inch (mm) | Bolt Capacity | Max Torque<br>FT-LB Nm | No Load Speed<br>R.P.M | Impact Rate<br>ipm   | Rating Voltage<br>V | Completely Charged<br>V | Net Weight<br>kg |
|----------|---------------------------|---------------|------------------------|------------------------|----------------------|---------------------|-------------------------|------------------|
| DW-406   | 1/2"(12.7)                | M10-M25       | 1200 1600              | 0-1400/0-1900/0-2400   | 0-1800/0-2200/0-2800 | 18                  | 20                      | 2.0              |

# DPW-101

CORDLESS PRESSURE WASHER GUN



| Item No. | Flow Rate | Hose Length | Maximum Pressure | Tool Length | Rating voltage | Completely charged | Net Weight |
|----------|-----------|-------------|------------------|-------------|----------------|--------------------|------------|
|          | L/min     | m           | PSI(bar)         | mm          | V              | V                  | kg         |
|          |           |             |                  |             |                |                    |            |
| DPW-101  | 2.8       | 4           | 360(25)          | 876         | 18             | 20                 | 1.72       |

# NC-4670Q

1/2" DRIVE AIR IMPACT WRENCH Jumbo hammer type



**SIDE TO SIDE**  
**1.1 KG**  
**650 FT-LB**



| Item No. | Square Drive | Bolt Capacity | Torque Range     |       | Max Torque |       | Free Speed  | Avg. Air Consumption | Air Pressure | Overall Length | Net Weight |      | Air Hose | Sound Pressure   | Vibration Level | Air Inlet |
|----------|--------------|---------------|------------------|-------|------------|-------|-------------|----------------------|--------------|----------------|------------|------|----------|------------------|-----------------|-----------|
|          | Inch         | Inch (mm)     | FT-LB (Nm)       | FT-LB | Nm         | R.P.M | CFM (L/min) | PSI (bar)            | Inch (mm)    | LBS            | kg         | Inch | dBA      | m/s <sup>2</sup> | Inch            |           |
|          |              |               |                  |       |            |       |             |                      |              |                |            |      |          |                  |                 |           |
| NC-4670Q | 1/2"         | 5/8"(16)      | 150-500(204-680) | 650   | 884        | 9000  | 5.2(147)    | 90(6.3)              | 4"(105)      | 2.4            | 1.1        | 3/8" | 85.0     | 3.3              | 1/4"            |           |

# NE-2900/NE-3900

1/4" & 3/8" DRIVE



## FEATURES

- No force is generated when used.
- Extremely small body that can be grasped with one hand.
- Compact size allows for greater access to tight spaces.
- Lightweight design reduces fatigue.

| Item No. | Square Drive | Torque Range   |       | Max Torque |       | Free Speed  | Avg. Air Consumption | Air Pressure | Overall Length | Net Weight |      | Air Hose | Sound Pressure   | Vibration Level | Air Inlet |
|----------|--------------|----------------|-------|------------|-------|-------------|----------------------|--------------|----------------|------------|------|----------|------------------|-----------------|-----------|
|          | Inch         | FT-LB (Nm)     | FT-LB | Nm         | R.P.M | CFM (L/min) | PSI (bar)            | Inch (mm)    | LBS            | kg         | Inch | dBA      | m/s <sup>2</sup> | Inch            |           |
|          |              |                |       |            |       |             |                      |              |                |            |      |          |                  |                 |           |
| NE-2900  | 1/4"         | 5-35(7.0-47.0) | 40    | 54.0       | 1000  | 3.4(96)     | 90(6.3)              | 6-1/4"(160)  | 1.43           | 0.65       | 3/8" | 80.0     | 2.3              | 1/4"            |           |
| NE-3900  | 3/8"         | 5-35(7.0-47.0) | 40    | 54.0       | 1000  | 3.4(96)     | 90(6.3)              | 6-1/4"(160)  | 1.43           | 0.65       | 3/8" | 80.0     | 2.3              | 1/4"            |           |



# NEW PRODUCT

## ★★★ **GTA-930/GTA-940/GTA-941**

### 3/8" / 1/2" / 1/2" DIGITAL ANGLE TORQUE ADAPTER

Accuracy : clockwise +/- 1.5% counterclockwise +/- 2.5%



| Item No. | Drive | Torque Range |            |     | Indicator | Torque Adjusting | D    | H   | L    | Weight |
|----------|-------|--------------|------------|-----|-----------|------------------|------|-----|------|--------|
|          | Inch  | Nm           | FT-LB      |     | LCD       |                  | mm   | mm  | mm   | kg     |
| GTA-930  | 3/8"  | 6.8-135      | 5.0-99.6   | LCD | Digital   | 32               | 31.8 | 361 | 0.77 |        |
| GTA-940  | 1/2"  | 10-200       | 7.4-147.5  | LCD | Digital   | 32               | 31.8 | 361 | 0.77 |        |
| GTA-941  | 1/2"  | 17-340       | 12.5-250.8 | LCD | Digital   | 32               | 31.8 | 361 | 0.77 |        |

### **MB47010M** HEX BALL BIT SOCKET SET

10pcs 1/2" Drive

- Contents : H6, H7, H8, H10, H12, H14, H15, H17, H18, H19
- Note : Not suitable for use with high power impact wrenches.



### **MB61008M** IMPACT SOCKET SET

8pcs 3/4" Drive

- Contents : M21, M22, M23, M24, M27, M30, M32, M36, M41



### **MB61016M** STD IMPACT SOCKET SET

16pcs 3/4" Drive

- Contents : M19, M21, M22, M24, M27, M28, M29, M30, M32, M33, M35, M36, M38, M41, M46, M50



### **MB63008S** IMPACT SOCKET SET

8pcs 3/4" Drive Inch Size

- Contents : 1-1/16", 1-1/8", 1-1/4", 1-5/16", 1-3/8", 1-7/16", 1-1/2"



### **MB63008M** DEEP IMPACT SOCKET SET

8pcs 3/4" Drive

- Contents : M21, M22, M24, M27, M30, M32, M36, M41



### **MB67006M** IMPACT HEX BALL BIT SOCKET SET

6pcs 3/4" Drive

- Contents : H14, H17, H19, H21, H24, H27
- Note : Not suitable for use with high power impact wrenches.



### **MB81009M** STD SOCKET SET

9pcs 1" Drive

- Contents : 27mm, 30mm, 32mm, 35mm, 36mm, 38mm, 41mm, 46mm, 50mm



### **MB85008M** DEEP SOCKET SET

8pcs 1" Drive

- Contents : 27mm, 30mm, 32mm, 36mm, 38mm, 41mm, 46mm, 50mm



# QA-688

## AIR DIE GRINDER FLEX-HEAD



### FEATURES

- Flexible head for accessing hard-to-reach areas.
- Small tool for spot sanding and finishing applications.
- Ideal for automotive aftermarket and light industry.

| Item No. | Collet Size<br>A mm | Collet Size<br>B inch | Free Speed<br>R.P.M | Avg. Air Consumption<br>CFM (L/min) | Air Pressure<br>PSI (bar) | Overall Length<br>Inch (mm) | Motor<br>HP | Net Weight<br>LBS<br>kg | Air Hose<br>Inch | Sound Pressure<br>dBA | Vibration Level<br>m/s <sup>2</sup> | Air Inlet<br>Inch |
|----------|---------------------|-----------------------|---------------------|-------------------------------------|---------------------------|-----------------------------|-------------|-------------------------|------------------|-----------------------|-------------------------------------|-------------------|
| QA-688   | 6 & 3               | 1/4" & 1/8"           | 20000               | 10(283)                             | 90(6.3)                   | 7"(178)                     | 0.3         | 1.4<br>0.65             | 3/8"             | 80.0                  | 1.1                                 | 1/4"              |

# SC-0320

## AIR VIBRATION INJECTOR PULLER



### FEATURES

- Design to replace the sliding hammer without hand using.
- Save the power and time to pull out the injector from engine.
- High torque and two speeds design for pull out the injector quickly.

| Item No. | Piston Stroke<br>mm | Stroke Speed<br>bpm | Max Torque<br>Nm | Spindle Thread | Working Pressure<br>PSI (bar) | Max. air Pressure<br>PSI (bar) | Overall Length<br>mm | Air Hose<br>mm | Weight<br>kg | Air Inlet<br>Inch |
|----------|---------------------|---------------------|------------------|----------------|-------------------------------|--------------------------------|----------------------|----------------|--------------|-------------------|
| SC-0320  | 38                  | 300/900             | 600              | M18 x 1.5      | 87-130.5(6-9)                 | 140.5(10)                      | 500                  | 12             | 2.7          | 1/4"              |

# SE-1001

## LED SLIM LIGHT



### FEATURES

- Magnet on back and bottom.
- Type-C charging port.

| Item No. | Size<br>mm     | Max output (Boost mode)<br>lm | Beam distance<br>m | Run time                            | Short press            | battery<br>v (mAh) | Weight<br>kg |
|----------|----------------|-------------------------------|--------------------|-------------------------------------|------------------------|--------------------|--------------|
| SE-1001  | 60 x 27.5 x 15 | 5 / 50 / 150 / 400            | 8 / 20 / 30 / 55   | 8 hrs / 2 hrs / 0.5 hr / 30 seconds | Low / Mid / High / OFF | 3.7 (300)          | 0.34         |

NEW PRODUCT

# AIR IMPACT WRENCH



## NC-3210

3/8" DRIVE Twin hammer type



10 pieces in one carton



## NC-3231Q

3/8" DRIVE Twin hammer type



10 pieces in one carton



## NC-3410

3/8" DRIVE Rocking dog type



20 pieces in one carton



## NC-3610Q

3/8" DRIVE Jumbo hammer type



10 pieces in one carton



## NC-3810

3/8" DRIVE Twin dog type



20 pieces in one carton



## NC-3812

3/8" DRIVE Twin dog type



10 pieces in one carton

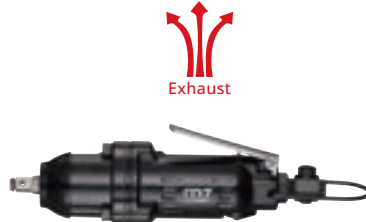

## NC-3831

3/8" DRIVE Twin dog type



10 pieces in one carton



## NC-3910

3/8" DRIVE Twin dog type



10 pieces in one carton



| Item No. | Square Drive | Bolt Capacity | Torque Range     | Max Torque |     | Free Speed | Avg. Air Consumption | Air Pressure | Overall Length | Net Weight |      | Air Hose | Sound Pressure | Vibration Level  | Air Inlet |
|----------|--------------|---------------|------------------|------------|-----|------------|----------------------|--------------|----------------|------------|------|----------|----------------|------------------|-----------|
|          | Inch         | Inch (mm)     | FT-LB (Nm)       | FT-LB      | Nm  | R.P.M      | CFM (L/min)          | PSI (bar)    | Inch (mm)      | LBS        | kg   | Inch     | dBA            | m/s <sup>2</sup> | Inch      |
| NC-3210  | 3/8"         | 1/2"(13)      | 100-300(136-407) | 350        | 474 | 10000      | 4.0(113)             | 90(6.3)      | 5-5/8"(142)    | 3.3        | 1.5  | 3/8"     | 92.1           | 3.6              | 1/4"      |
| NC-3231Q | 3/8"         | 1/2"(13)      | 200-350(271-475) | 450        | 610 | 8000       | 4.2(129)             | 90(6.3)      | 6-5/16"(160)   | 2.8        | 1.3  | 3/8"     | 83.0           | 3.0              | 1/4"      |
| NC-3410  | 3/8"         | 3/8"(10)      | 5-50(7-68)       | 75         | 102 | 10000      | 2.5(71)              | 90(6.3)      | 6-1/4"(159)    | 1.7        | 0.80 | 3/8"     | 92.1           | 3.6              | 1/4"      |
| NC-3610Q | 3/8"         | 1/2"(13)      | 100-300(136-407) | 350        | 474 | 8000       | 4.4(124)             | 90(6.3)      | 4-9/16"(115.5) | 3.3        | 1.50 | 3/8"     | 85.0           | 2.8              | 1/4"      |
| NC-3810  | 3/8"         | 3/8"(10)      | 5-50(7-67)       | 75         | 101 | 11000      | 2.3(6.5)             | 90(6.3)      | 5-15/32"(139)  | 1.1        | 0.50 | 3/8"     | 91.0           | 3.6              | 1/4"      |
| NC-3812  | 3/8"         | M10-M12       | 60-120(81-162)   | 180        | 244 | 8000       | 10(283)              | 90(6.3)      | 7-31/64"(190)  | 2.3        | 1.06 | 3/8"     | 97.0           | 5.1              | 1/4"      |
| NC-3831  | 3/8"         | 5/32"(M12)    | 80-120(108-162)  | 180        | 244 | 8000       | 10(283)              | 90(6.3)      | 7-9/32"(185)   | 2.9        | 1.34 | 3/8"     | 93.0           | 4.9              | 1/4"      |
| NC-3910  | 3/8"         | 5-16"(8)      | 5-37(7-50)       | 66         | 89  | 8500       | 8.5(240)             | 90(6.3)      | 10-7/16"(265)  | 3.5        | 1.60 | 3/8"     | 90.0           | 5.1              | 1/4"      |

**NC-3911**  
**3/8" DRIVE** Twin dog type  
 ★★ ★   
 10 pieces in one carton



**NC-398**  
**3/8" DRIVE** Jumbo hammer type  
 ★★ ★   
 12 pieces in one carton



**RA-111**  
**3/8" DRIVE** Twin hammer type  
 ★★ ★   
 10 pieces in one carton



**NC-4117**  
**1/2" DRIVE** Pin clutch type  
 ★★ ★   
 8 pieces in one carton



**NC-4130**  
**1/2" DRIVE** Pin clutch type  
 ★★ ★   
 10 pieces in one carton



**NC-4210/NC-4210N**  
**1/2" DRIVE** Twin hammer type  
 ★★ ★   
 10 pieces in one carton



**NC-4213/NC-4223**  
**1/2" DRIVE** Twin hammer type  
 ★★ ★   
 10 pieces in one carton 4 pieces in one carton



**NC-4217**  
**1/2" DRIVE** Twin hammer type  
 ★★ ★   
 8 pieces in one carton



**NC-4230/NC-4230Q/NC-4240**  
**1/2" DRIVE** Twin hammer type  
 ★★ ★   
 8 pieces in one carton



| Item No. | Square Drive |               | Torque Range     | Max Torque |       | Free Speed | Avg. Air Consumption | Air Pressure | Overall Length | Net Weight |       | Air Hose | Sound Pressure | Vibration Level | Air Inlet |
|----------|--------------|---------------|------------------|------------|-------|------------|----------------------|--------------|----------------|------------|-------|----------|----------------|-----------------|-----------|
|          | Inch         | Bolt Capacity |                  | FT-LB (Nm) | FT-LB |            |                      |              |                | Nm         | R.P.M |          |                |                 |           |
| NC-3911  | 3/8"         | 3/8"(10)      | 5-44(7-60)       | 96         | 130   | 7000       | 7.0(198)             | 90(6.3)      | 9-7/16"(240)   | 3.5        | 1.60  | 3/8"     | 92.0           | 5.1             | 1/4"      |
| NC-398   | 3/8"         | 9/16"(14)     | 50-200(68-271)   | 300        | 407   | 6500       | 4.2(119)             | 90(6.3)      | 9-3/4"(247)    | 3.0        | 1.37  | 3/8"     | 85.0           | 2.0             | 1/4"      |
| RA-111   | 3/8"         | 5/16"(8)      | 3.7-36.9(5-50)   | 50         | 68    | 8500       | 8.5(255)             | 90(6.3)      | 8-1/4"(208)    | 2.2        | 1.0   | 3/8"     | 96.7           | 4.9             | 1/4"      |
| NC-4117  | 1/2"         | 3/4"(18)      | 200-550(271-746) | 700        | 949   | 7000       | 5.4(153)             | 90(6.3)      | 8"(205)        | 4.3        | 1.95  | 3/8"     | 90.0           | 2.5             | 1/4"      |
| NC-4130  | 1/2"         | 5/8"(16)      | 180-400(244-542) | 600        | 813   | 9000       | 4.5(127)             | 90(6.3)      | 5-9/16"(142)   | 3.55       | 1.61  | 3/8"     | 93.0           | 1.2             | 1/4"      |
| NC-4210  | 1/2"         | 5/8"(16)      | 150-350(203-475) | 400        | 542   | 10000      | 4.2(119)             | 90(6.3)      | 5-5/8"(142)    | 3.5        | 1.60  | 3/8"     | 90.6           | 2.8             | 1/4"      |
| NC-4210N | 1/2"         | 5/8"(16)      | 150-350(203-475) | 400        | 542   | 10000      | 4.2(119)             | 90(6.3)      | 5-5/8"(142)    | 3.5        | 1.60  | 3/8"     | 90.6           | 2.8             | 1/4"      |
| NC-4213  | 1/2"         | 5/8"(16)      | 180-400(244-542) | 600        | 813   | 6500       | 4.2(119)             | 90(6.3)      | 7-3/16"(182)   | 6.2        | 2.80  | 3/8"     | 91.0           | 3.8             | 1/4"      |
| NC-4223  | 1/2"         | 5/8"(16)      | 180-400(244-542) | 600        | 813   | 6500       | 4.2(119)             | 90(6.3)      | 9-1/4"(232)    | 6.4        | 2.90  | 3/8"     | 91.0           | 3.8             | 1/4"      |
| NC-4217  | 1/2"         | 5/8"(16)      | 150-320(203-434) | 400        | 542   | 7000       | 4.2(119)             | 90(6.3)      | 7-1/4"(184)    | 5.6        | 2.50  | 3/8"     | 92.1           | 3.7             | 1/4"      |
| NC-4230  | 1/2"         | 3/4"(19)      | 180-500(244-678) | 700        | 949   | 7500       | 4.5(127)             | 90(6.3)      | 6-15/32"(164)  | 5.5        | 2.50  | 3/8"     | 87.0           | 4.5             | 1/4"      |
| NC-4230Q | 1/2"         | 3/4"(19)      | 180-500(244-678) | 650        | 881   | 6500       | 4.5(127)             | 90(6.3)      | 6-15/32"(164)  | 5.5        | 2.50  | 3/8"     | 85.0           | 4.5             | 1/4"      |
| NC-4240  | 1/2"         | 3/4"(19)      | 180-500(244-678) | 700        | 949   | 7500       | 4.5(127)             | 90(6.3)      | 8-15/32"(215)  | 5.7        | 2.60  | 3/8"     | 87.0           | 4.5             | 1/4"      |

# AIR IMPACT WRENCH

## NC-4232Q

1/2" DRIVE Twin hammer type



10 pieces in one carton



## NC-4233Q/NC-4233QH

1/2" DRIVE Twin hammer type



8 pieces in one carton

Patent grease hole

NC-4233QH

- EZ GREASE ANVIL
- For EZ grease version only



## NC-4233TL

1/2" DRIVE Twin hammer type



8 pieces in one carton

- Forward operation torque is limited 50-80 Nm for vehicle tire service.
- 6 rotor-blades makes efficient starting torque.



## NC-4236/NC-4236Q

1/2" DRIVE Twin hammer type



8 pieces in one carton



## NC-4256/NC-4256Q/NC-4256Q-2

1/2" DRIVE Twin hammer type



10 pieces in one carton



## NC-4255Q/NC-4265Q

1/2" DRIVE Twin hammer type



8 pieces in one carton

Patent grease hole  
For EZ grease version only



## NC-4255QP

With protective cover inside

8 pieces in one carton



## NC-4255QH

EZ grease anvil



## NC-4255PVC

Protective cover



The NC-4255PVC protective boot can apply on NC-4255Q & NC-6255Q

| Item No.   | Square Drive |               | Torque Range      | Max Torque |      | Free Speed | Avg. Air Consumption | Air Pressure | Overall Length | Net Weight |             | Air Hose | Sound Pressure | Vibration Level | Air Inlet |
|------------|--------------|---------------|-------------------|------------|------|------------|----------------------|--------------|----------------|------------|-------------|----------|----------------|-----------------|-----------|
|            | Inch         | Bolt Capacity |                   | FT-LB      | Nm   |            |                      |              |                | R.P.M      | CFM (L/min) |          |                |                 |           |
| NC-4232Q   | 1/2"         | 5/8"(16)      | 100-400(136-542)  | 550        | 746  | 10000      | 4.0(113)             | 90(6.3)      | 4-3/4"(120)    | 3.0        | 1.38        | 3/8"     | 83.0           | 3.7             | 1/4"      |
| NC-4233Q   | 1/2"         | 3/4"(19)      | 200-500(271-678)  | 850        | 1152 | 9000       | 4.6(132)             | 90(6.3)      | 7-1/2"(190)    | 4.6        | 2.10        | 3/8"     | 85.0           | 4.4             | 1/4"      |
| NC-4233QH  | 1/2"         | 3/4"(19)      | 200-500(271-678)  | 850        | 1152 | 9000       | 4.6(132)             | 90(6.3)      | 7-1/2"(190)    | 4.6        | 2.10        | 3/8"     | 85.0           | 4.4             | 1/4"      |
| NC-4233TL  | 1/2"         | 3/4"(19)      | 37-59(50-80)      | 850        | 1152 | 2800       | 4.6(132)             | 90(6.3)      | 7-1/2"(190)    | 4.6        | 2.10        | 3/8"     | 85.0           | 4.4             | 1/4"      |
| NC-4236    | 1/2"         | 1"(25)        | 200-700(271-949)  | 1000       | 1355 | 7500       | 5.5(155)             | 90(6.3)      | 6-45/64"(171)  | 5.7        | 2.60        | 3/8"     | 87.0           | 4.5             | 1/4"      |
| NC-4236Q   | 1/2"         | 1"(25)        | 200-700(271-949)  | 1000       | 1355 | 7500       | 5.5(155)             | 90(6.3)      | 6-45/64"(171)  | 5.7        | 2.60        | 3/8"     | 83.0           | 4.5             | 1/4"      |
| NC-4256    | 1/2"         | 1"(25)        | 200-900(271-1220) | 1100       | 1491 | 9000       | 5.1(144)             | 90(6.3)      | 5-9/16"(141)   | 4.0        | 1.80        | 3/8"     | 95.0           | 2.8             | 1/4"      |
| NC-4256Q   | 1/2"         | 1"(25)        | 200-900(271-1220) | 1000       | 1356 | 7000       | 5.1(144)             | 90(6.3)      | 5-9/16"(141)   | 4.0        | 1.80        | 3/8"     | 85.0           | 2.8             | 1/4"      |
| NC-4256Q-2 | 1/2"         | 1"(25)        | 200-900(271-1220) | 1000       | 1356 | 7000       | 5.1(144)             | 90(6.3)      | 7-9/16"(191)   | 4.2        | 1.90        | 3/8"     | 85.0           | 2.8             | 1/4"      |
| NC-4255Q   | 1/2"         | 1"(25)        | 200-800(271-1085) | 1200       | 1627 | 8500       | 4.8(136)             | 90(6.3)      | 7-1/32"(179)   | 3.7        | 1.70        | 3/8"     | 85.0           | 4.7             | 1/4"      |
| NC-4255QP  | 1/2"         | 1"(25)        | 200-800(271-1085) | 1200       | 1627 | 8500       | 4.8(136)             | 90(6.3)      | 7-1/32"(179)   | 4.0        | 1.80        | 3/8"     | 85.0           | 4.7             | 1/4"      |
| NC-4255QH  | 1/2"         | 1"(25)        | 200-800(271-1085) | 1200       | 1627 | 8500       | 4.8(136)             | 90(6.3)      | 7-1/32"(179)   | 3.7        | 1.70        | 3/8"     | 85.0           | 4.7             | 1/4"      |
| NC-4265Q   | 1/2"         | 1"(25)        | 200-800(271-1085) | 1200       | 1627 | 8500       | 4.8(136)             | 90(6.3)      | 9-1/32"(230.5) | 3.85       | 1.75        | 3/8"     | 85.0           | 4.7             | 1/4"      |

### NC-4258

1/2" DRIVE Twin hammer type

★★★

8 pieces in one carton



### NC-4277Q

1/2" DRIVE Twin hammer type

★★★

10 pieces in one carton



### NC-4299Q

1/2" DRIVE Twin hammer type

★★★

10 pieces in one carton



### NC-4600

1/2" DRIVE Jumbo hammer type

★★★

10 pieces in one carton



### NC-4610/NC-4610Q/NC-4610N

1/2" DRIVE Jumbo hammer type

★★★

10 pieces in one carton



### NC-4630/NC-4630Q

1/2" DRIVE Jumbo hammer type

★★★

10 pieces in one carton



### NC-4650 NC-4650H

1/2" DRIVE Jumbo hammer type

★★★

10 pieces in one carton

Patent grease hole  
For EZ grease version only



### NC-4811

1/2" DRIVE Twin dog type

★★★

10 pieces in one carton



### NC-498

1/2" DRIVE Jumbo hammer type

★★★

12 pieces in one carton



| Item No. | Square Drive |           | Torque Range      |       | Max Torque |       | Free Speed  | Avg. Air Consumption | Air Pressure   | Overall Length |      | Net Weight |   | Air Hose | Sound Pressure   | Vibration Level | Air Inlet |
|----------|--------------|-----------|-------------------|-------|------------|-------|-------------|----------------------|----------------|----------------|------|------------|---|----------|------------------|-----------------|-----------|
|          | Inch         | Inch (mm) | FT-LB (Nm)        | FT-LB | Nm         | R.P.M | CFM (L/min) | PSI (bar)            | Inch (mm)      | LBS            | kg   | Inch       | ↓ | dBA      | m/s <sup>2</sup> | Inch            |           |
| NC-4258  | 1/2"         | 5/8"(16)  | 150-300(203-407)  | 400   | 542        | 7000  | 4.2(119)    | 90(6.3)              | 7-1/4"(185)    | 5.6            | 2.50 | 3/8"       | ↑ | 93.0     | 4.4              | 1/4"            |           |
| NC-4277Q | 1/2"         | 1"(25)    | 200-800(271-1088) | 1150  | 1564       | 7000  | 4.8(136)    | 90(6.3)              | 6"(155)        | 4.4            | 2    | 3/8"       |   | 85.0     | 4.5              | 1/4"            |           |
| NC-4299Q | 1/2"         | 3/4"(19)  | 150-500(204-680)  | 800   | 1088       | 8500  | 4.0(113)    | 90(6.3)              | 7-1/2"(194)    | 4.6            | 2.1  | 3/8"       |   | 85.0     | 3.2              | 1/4"            |           |
| NC-4600  | 1/2"         | 5/8"(16)  | 180-500(244-678)  | 600   | 813        | 9000  | 4.2(119)    | 90(6.3)              | 4"(99)         | 2.97           | 1.35 | 3/8"       |   | 96.0     | 3.7              | 1/4"            |           |
| NC-4610  | 1/2"         | 5/8"(16)  | 200-350(271-475)  | 450   | 610        | 9000  | 4.4(124)    | 90(6.3)              | 4-9/16"(115.5) | 3.5            | 1.60 | 3/8"       |   | 93.0     | 2.8              | 1/4"            |           |
| NC-4610Q | 1/2"         | 5/8"(16)  | 200-350(271-475)  | 400   | 542        | 9000  | 4.4(124)    | 90(6.3)              | 4-9/16"(115.5) | 3.5            | 1.60 | 3/8"       |   | 85.0     | 2.8              | 1/4"            |           |
| NC-4610N | 1/2"         | 5/8"(16)  | 200-350(271-475)  | 450   | 610        | 9000  | 4.4(124)    | 90(6.3)              | 4-9/16"(115.5) | 3.5            | 1.60 | 3/8"       |   | 93.0     | 2.8              | 1/4"            |           |
| NC-4630  | 1/2"         | 5/8"(16)  | 100-400(136-542)  | 450   | 610        | 9000  | 4.4(124)    | 90(6.3)              | 3-27/32"(97)   | 3.3            | 1.50 | 3/8"       |   | 96.0     | 2.8              | 1/4"            |           |
| NC-4630Q | 1/2"         | 5/8"(16)  | 200-350(271-475)  | 450   | 610        | 9000  | 4.4(124)    | 90(6.3)              | 3-27/32"(97)   | 3.3            | 1.50 | 3/8"       |   | 85.0     | 2.8              | 1/4"            |           |
| NC-4650  | 1/2"         | 5/8"(16)  | 180-400(244-542)  | 650   | 900        | 9000  | 4.69(132.8) | 90(6.3)              | 4-1/16"(104)   | 3.3            | 1.40 | 3/8"       |   | 95.0     | 2.4              | 1/4"            |           |
| NC-4650H | 1/2"         | 5/8"(16)  | 180-400(244-542)  | 650   | 900        | 9000  | 4.69(132.8) | 90(6.3)              | 4-1/16"(104)   | 3.3            | 1.40 | 3/8"       |   | 95.0     | 2.4              | 1/4"            |           |
| NC-4811  | 1/2"         | 9/16"(14) | 118-140(160-189)  | 210   | 285        | 5500  | 8.5(240)    | 90(6.3)              | 10-9/32"(260)  | 3.7            | 1.70 | 3/8"       |   | 85.0     | 5.3              | 1/4"            |           |
| NC-498   | 1/2"         | 5/8"(16)  | 80-300(108-407)   | 400   | 542        | 6500  | 4.2(119)    | 90(6.3)              | 9-3/4"(247)    | 3.0            | 1.37 | 3/8"       |   | 85.0     | 2.0              | 1/4"            |           |

# AIR IMPACT WRENCH

## NC-6113/NC-6123

3/4" DRIVE Pin clutch type



4 pieces in one carton



NC-6123

## NC-6201

3/4" DRIVE Twin hammer type



6 pieces in one carton



## NC-6210Q

3/4" DRIVE Twin hammer type



8 pieces in one carton



## NC-6215/NC-6225

3/4" DRIVE Twin hammer type



4 pieces in one carton

- NC-6225 is equipped with 6" extended anvil



NC-6225

## NC-6216/NC-6226

3/4" DRIVE New twin hammer type



4 pieces in one carton

- NC-6226 is equipped with 6" extended anvil
- Composite material



NC-6226

NC-6216PVC

- Protective cover

## NC-6217

3/4" DRIVE Twin hammer type



4 pieces in one carton



## NC-6218/NC-6218-6

3/4" DRIVE Twin hammer type



2 pieces in one carton

- NC-6218-6 is equipped with 6" extended anvil



## NC-6233Q

3/4" DRIVE Twin hammer type



6 pieces in one carton



| Item No.  | Square Drive |             | Torque Range       | Max Torque |       | Free Speed | Avg. Air Consumption | Air Pressure | Overall Length | Net Weight |       | Air Hose | Sound Pressure | Vibration Level | Air Inlet |
|-----------|--------------|-------------|--------------------|------------|-------|------------|----------------------|--------------|----------------|------------|-------|----------|----------------|-----------------|-----------|
|           | Inch         | Inch (mm)   |                    | FT-LB (Nm) | FT-LB |            |                      |              |                | Nm         | R.P.M |          |                |                 |           |
| NC-6113   | 3/4"         | 1"(25)      | 150-600(203-814)   | 850        | 1153  | 4500       | 7.0(198)             | 90(6.3)      | 10"(252)       | 10.1       | 4.6   | 1/2"     | 94.3           | 7.2             | 1/4"      |
| NC-6123   | 3/4"         | 1"(25)      | 150-600(203-814)   | 850        | 1163  | 4500       | 7.0(198)             | 90(6.3)      | 14-3/16"(360)  | 11.6       | 5.30  | 1/2"     | 94.3           | 7.2             | 1/4"      |
| NC-6201   | 3/4"         | 1-3/16"(30) | 200-1200(271-1627) | 1450       | 1966  | 5700       | 6.4(181)             | 90(6.3)      | 8-3/4"(222)    | 8.14       | 3.7   | 1/2"     | 88.0           | 5.9             | 3/8"      |
| NC-6210Q  | 3/4"         | 3/4"(19)    | 180-600(244-810)   | 700        | 949   | 6500       | 4.5(127)             | 90(6.3)      | 6-45/64"(170)  | 5.6        | 2.55  | 3/8"     | 85.0           | 4.5             | 3/8"      |
| NC-6215   | 3/4"         | 1"(25)      | 180-600(244-810)   | 900        | 1220  | 6500       | 7.0(198)             | 90(6.3)      | 9-7/32"(234)   | 10.0       | 4.50  | 1/2"     | 91.5           | 10.8            | 1/4"      |
| NC-6225   | 3/4"         | 1"(25)      | 180-600(244-810)   | 900        | 1220  | 6500       | 7.0(182)             | 90(6.3)      | 13-3/4"(350)   | 10.8       | 4.90  | 1/2"     | 91.5           | 10.8            | 1/4"      |
| NC-6216   | 3/4"         | 1"(25)      | 200-900(271-1220)  | 1100       | 1491  | 9000       | 5.1(144)             | 90(6.3)      | 5-9/16"(141)   | 4.0        | 1.80  | 1/2"     | 95.0           | 2.8             | 3/8"      |
| NC-6226   | 3/4"         | 1"(25)      | 200-900(271-1220)  | 1000       | 1356  | 7000       | 5.1(144)             | 90(6.3)      | 5-9/16"(141)   | 4.0        | 1.80  | 1/2"     | 85.0           | 2.8             | 3/8"      |
| NC-6217   | 3/4"         | 1-1/4"(30)  | 200-1300(271-1762) | 1400       | 1898  | 4800       | 5.4(153)             | 90(6.3)      | 8-15/32"(215)  | 11.0       | 1.90  | 1/2"     | 92.0           | 6.1             | 3/8"      |
| NC-6218   | 3/4"         | 1-1/16"(27) | 200-1400(271-1898) | 1500       | 2034  | 6000       | 6.3(182)             | 90(6.3)      | 12-9/16"(320)  | 12.5       | 1.70  | 1/2"     | 106.0          | 3.3             | 3/8"      |
| NC-6218-6 | 3/4"         | 1-1/16"(27) | 200-1400(271-1898) | 1500       | 2034  | 6000       | 6.3(182)             | 90(6.3)      | 18-1/2"(470)   | 6.1        | 13.42 | 1/2"     | 106.0          | 3.3             | 3/8"      |
| NC-6233Q  | 3/4"         | 1"(25)      | 200-800(271-1085)  | 1200       | 1627  | 8500       | 4.8(136)             | 90(6.3)      | 7-1/32"(179)   | 3.7        | 1.70  | 1/2"     | 85.0           | 4.7             | 1/4"      |

## NC-6236 NC-6236Q

3/4" DRIVE Twin hammer type



8 pieces in one carton



## NC-6255Q/NC-6255QH

3/4" DRIVE Twin hammer type



8 pieces in one carton

NC-6255QH

Patent grease hole  
For EZ grease version only



## NC-6256Q

3/4" DRIVE Twin hammer type



6 pieces in one carton



1627 N.m  
SUPER MINI

## NC-6266/NC-6266-6

3/4" DRIVE Twin hammer type



4 pieces in one carton

• NC-6266-6 is equipped with 6" extended anvil



NC-6266-6

## NC-6266H

3/4" DRIVE Twin hammer type



6 pieces in one carton

Patent grease hole  
For EZ grease version only



## NC-8211/NC-8221

1" DRIVE Twin hammer type



1 pieces in one carton

• NC-8221 is equipped with 6" extended anvil

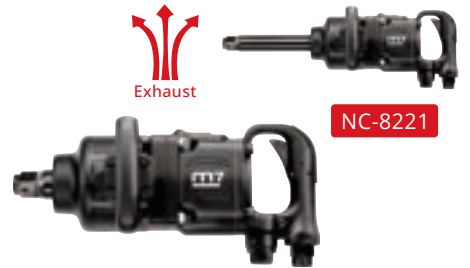

NC-8221

## NC-8212

1" DRIVE Twin hammer type



4 pieces in one carton



## NC-8216 NC-8226 NC-8226Q

1" DRIVE Twin hammer type



2 pieces in one carton

• NC-8226 is equipped with 6" extended anvil



NC-8226

| Item No.  | Square Drive | Bolt Capacity | Torque Range       |       | Max Torque |       | Free Speed  | Avg. Air Consumption | Air Pressure  | Overall Length | Net Weight |      | Air Hose | Sound Pressure   | Vibration Level | Air Inlet |
|-----------|--------------|---------------|--------------------|-------|------------|-------|-------------|----------------------|---------------|----------------|------------|------|----------|------------------|-----------------|-----------|
|           | Inch         | Inch (mm)     | FT-LB (Nm)         | FT-LB | Nm         | R.P.M | CFM (L/min) | PSI (bar)            | Inch (mm)     | LBS            | kg         | Inch | dBA      | m/s <sup>2</sup> | Inch            |           |
| NC-6236   | 3/4"         | 1"(25)        | 200-900(271-1220)  | 1200  | 1627       | 7500  | 5.5(155)    | 90(6.3)              | 6-45/64"(171) | 5.9            | 2.68       | 3/8" | 87.0     | 4.5              | 1/4"            |           |
| NC-6236Q  | 3/4"         | 1"(25)        | 200-900(271-1220)  | 1200  | 1627       | 7500  | 5.5(155)    | 90(6.3)              | 6-45/64"(171) | 5.9            | 2.68       | 3/8" | 83.0     | 4.5              | 1/4"            |           |
| NC-6255Q  | 3/4"         | 1"(25)        | 200-1300(271-1491) | 1400  | 1898       | 8500  | 4.8(136)    | 90(6.3)              | 7-13/16"(198) | 4.2            | 1.9        | 3/8" | 85.0     | 4.7              | 1/4"            |           |
| NC-6255QH | 3/4"         | 1"(25)        | 200-1300(271-1491) | 1400  | 1898       | 8500  | 4.8(136)    | 90(6.3)              | 7-13/16"(198) | 4.2            | 1.9        | 3/8" | 85.0     | 4.7              | 1/4"            |           |
| NC-6256Q  | 3/4"         | 7/8"(23)      | 150-900(203-1220)  | 1200  | 1627       | 7000  | 5.1(144)    | 90(6.3)              | 5-11/16"(145) | 4.18           | 1.9        | 3/8" | 85.0     | 2.8              | 1/4"            |           |
| NC-6266   | 3/4"         | 1-1/4"(30)    | 200-1300(271-1760) | 1500  | 2034       | 6000  | 5.9(169)    | 90(6.3)              | 8-1/16"(205)  | 6.5            | 2.95       | 1/2" | 88.0     | 5.9              | 3/8"            |           |
| NC-6266-6 | 3/4"         | 1-1/4"(30)    | 200-1300(271-1760) | 1500  | 2034       | 6000  | 5.9(169)    | 90(6.3)              | 14-1/16"(355) | 7.9            | 3.60       | 1/2" | 88.0     | 5.9              | 3/8"            |           |
| NC-6266H  | 3/4"         | 1-1/4"(30)    | 200-1600(271-1760) | 1500  | 2034       | 6000  | 5.9(169)    | 90(6.3)              | 8-1/16"(205)  | 6.5            | 3          | 1/2" | 88.0     | 5.9              | 3/8"            |           |
| NC-8211   | 1"           | 1-3/8"(33)    | 200-1600(271-2170) | 1800  | 2441       | 5000  | 10.0(284)   | 90(6.3)              | 14-9/16"(370) | 22.2           | 10.1       | 1/2" | 100      | 10.0             | 1/2"            |           |
| NC-8221   | 1"           | 1-3/8"(33)    | 200-1600(271-2170) | 1800  | 2441       | 5000  | 10.0(284)   | 90(6.3)              | 20-7/8"(530)  | 25.2           | 11.5       | 1/2" | 100      | 10.0             | 1/2"            |           |
| NC-8212   | 1"           | 1-1/16"(27)   | 200-1000(271-1356) | 1300  | 1762       | 6000  | 6.0(170)    | 90(6.3)              | 9-1/4"(235)   | 9.6            | 4.40       | 1/2" | 91.2     | 5.0              | 3/8"            |           |
| NC-8216   | 1"           | 1-3/8"(33)    | 200-1600(271-2170) | 1800  | 2441       | 6000  | 9.0(254)    | 90(6.3)              | 13-1/2"(343)  | 15.5           | 7.0        | 1/2" | 102      | 9.3              | 1/2"            |           |
| NC-8226   | 1"           | 1-3/8"(33)    | 200-1600(271-2170) | 1800  | 2441       | 6000  | 9.0(254)    | 90(6.3)              | 19-3/16"(487) | 18.4           | 8.4        | 1/2" | 102      | 9.3              | 1/2"            |           |
| NC-8226Q  | 1"           | 1-3/8"(33)    | 200-1600(271-2170) | 1800  | 2441       | 6000  | 9.0(254)    | 90(6.3)              | 19-3/16"(487) | 18.4           | 8.4        | 1/2" | 90       | 9.3              | 1/2"            |           |



# AIR IMPACT WRENCH

## NC-8217

1" DRIVE Twin hammer type



4 pieces in one carton



## NC-8219

1" DRIVE New twin hammer type



2 pieces in one carton

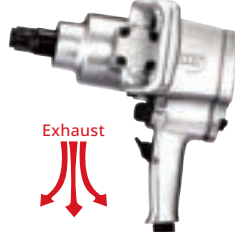

## NC-8232

1" DRIVE New twin hammer type



1 pieces in one carton

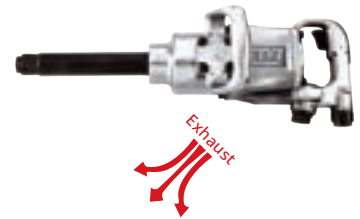

## NC-8237 NC-8237-6

1" DRIVE Twin hammer type



4 pieces in one carton

- NC-8237-6 is equipped with 6" extended anvil



## NC-8242 NC-8242-8

1" DRIVE Twin hammer type



2 pieces in one carton 1 pieces in one carton

- NC-8242-8 is equipped with 8" extended anvil

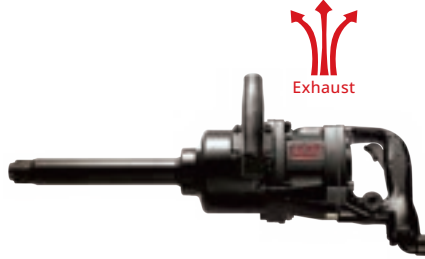

## NC-8252 NC-8262

1" DRIVE Twin hammer type



1 pieces in one carton

- NC-8262 is equipped with 6" extended anvil



## NC-8260 NC-8260-6

1" DRIVE Twin hammer type



6 pieces in one carton

- NC-8260-6 is equipped with 6" extended anvil



## NC-8266P NC-8266P-6

1" DRIVE Twin hammer type



2 pieces in one carton

- NC-8266P-6 is equipped with 6" extended anvil



## NC-8266S NC-8266S-6 NC-8266S-8

1" DRIVE Twin hammer type



2 pieces in one carton

- NC-8266S-6 is equipped with 6" extended anvil
- NC-8266S-8 is equipped with 8" extended anvil



## NC-8311 NC-8351

1" DRIVE Pin less type



2 pieces in one carton

- NC-8351 is equipped with 6" extended anvil

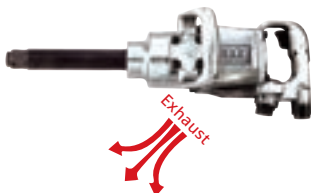

## NC-8322 NC-8342

1" DRIVE Pin less type



1 pieces in one carton

- NC-8342 is equipped with 8" extended anvil

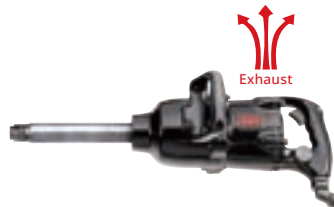

## NC-8331 NC-8331-6

1" DRIVE Pin less type



2 pieces in one carton

- NC-8331-6 is equipped with 6" extended anvil



# NC-8332X NC-8332X-6

1" DRIVE Pin less type



2 pieces in one carton

- NC-8332X-6 is equipped with 6" extended anvil

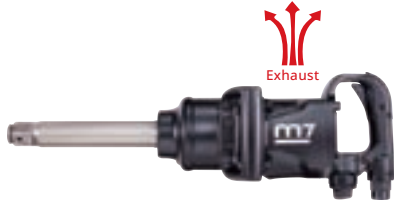

# NC-8343 NC-8343-8

1" DRIVE Pin less type



1 pieces in one carton

- NC-8343-8 is equipped with 8" extended anvil



# NC-8362 NC-8372

1" DRIVE Pin less type



1 pieces in one carton

- NC-8372 is equipped with 6" extended anvil



# NC-8382/NC-8382-8

1" DRIVE Pin less type



2 pieces in one carton 1 pieces in one carton

- NC-8382-8 is equipped with 8" extended anvil

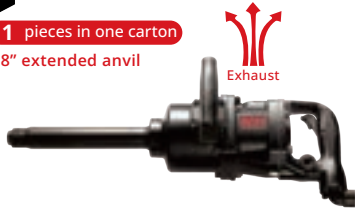

# NC-9223/NC-9243

1-1/2" DRIVE New twin hammer type



1 pieces in one carton

- NC-9243 is equipped with 8" extended anvil



| Item No.   | Square Drive | Bolt Capacity | Torque Range       | Max Torque | Free Speed | Avg. Air Consumption | Air Pressure | Overall Length   | Net Weight | Air Hose | Sound Pressure | Vibration Level  | Air Inlet |
|------------|--------------|---------------|--------------------|------------|------------|----------------------|--------------|------------------|------------|----------|----------------|------------------|-----------|
|            | Inch         | Inch (mm)     | FT-LB (Nm)         | FT-LB Nm   | R.P.M      | CFM (L/min)          | PSI (bar)    | Inch (mm)        | LBS kg     | Inch     | dBA            | m/s <sup>2</sup> | Inch      |
| NC-8217    | 1"           | 1-1/4"(30)    | 200-1300(271-1762) | 1500 2034  | 4800       | 5.4(153)             | 90(6.3)      | 8-3/4"(222)      | 11.0 5.00  | 1/2"     | 92.0           | 6.1              | 3/8"      |
| NC-8219    | 1"           | 1-7/16"(36)   | 200-1600(271-2170) | 1800 2441  | 4000       | 11.0(311)            | 90(6.3)      | 12-13/32"(315)   | 21.6 9.84  | 1/2"     | 103.4          | 16.7             | 1/2"      |
| NC-8232    | 1"           | 1-7/16"(36)   | 200-1600(271-2170) | 1800 2441  | 4000       | 11.0(311)            | 90(6.3)      | 20-13/32"(518)   | 24.8 11.3  | 1/2"     | 102            | 11.5             | 1/2"      |
| NC-8237    | 1"           | 1-3/8"(33)    | 200-1500(271-2034) | 1800 2441  | 4500       | 5.4(153)             | 90(6.3)      | 8-3/4"(222)      | 12.8 5.70  | 1/2"     | 92.0           | 6.1              | 3/8"      |
| NC-8237-6  | 1"           | 1-3/8"(33)    | 200-1500(203-2034) | 1800 2441  | 4500       | 5.4(153)             | 90(6.3)      | 15-9/16"(395)    | 14.3 6.50  | 1/2"     | 92.0           | 6.1              | 3/8"      |
| NC-8242    | 1"           | 1-9/16"(40)   | 200-2000(271-2710) | 2500 3390  | 5000       | 15.9(450)            | 90(6.3)      | 14-17/32"(370)   | 23.1 10.5  | 1/2"     | 100.0          | 6.4              | 1/2"      |
| NC-8242-8  | 1"           | 1-9/16"(40)   | 200-2000(271-2710) | 2500 3390  | 5000       | 15.9(450)            | 90(6.3)      | 22-15/32"(570)   | 26.2 11.9  | 1/2"     | 100.0          | 6.4              | 1/2"      |
| NC-8252    | 1"           | 1-7/16"(36)   | 200-2000(271-2710) | 2400 3250  | 4000       | 10.0(284)            | 90(6.3)      | 15-3/8"(390)     | 26.6 12.1  | 1/2"     | 100.0          | 10.0             | 1/2"      |
| NC-8262    | 1"           | 1-7/16"(36)   | 200-2000(271-2710) | 2500 3390  | 3700       | 11.0(284)            | 90(6.3)      | 17-7/8"(155)     | 35.2 16.0  | 1/2"     | 93.9           | 8.8              | 1/2"      |
| NC-8260    | 1"           | 1-1/4"(32)    | 200-1600(271-2169) | 1750 2372  | 6000       | 7.5(212)             | 90(6.3)      | 8-1/2"(218)      | 6.82 3.1   | 1/2"     | 87.0           | 5.9              | 3/8"      |
| NC-8260-6  | 1"           | 1-1/4"(32)    | 200-1600(271-2169) | 1750 2372  | 6000       | 7.5(212)             | 90(6.3)      | 14"(355)         | 9.0 4.1    | 1/2"     | 87.0           | 5.9              | 3/8"      |
| NC-8266P   | 1"           | 1-3/8"(35)    | 200-2000(271-2711) | 2300 3118  | 4500       | 9.0(255)             | 90(6.3)      | 10"(256)         | 13 5.90    | 1/2"     | 92.0           | 6.1              | 1/2"      |
| NC-8266P-6 | 1"           | 1-3/8"(35)    | 200-2000(271-2711) | 2300 3118  | 4500       | 9.0(255)             | 90(6.3)      | 16-7/16"(418)    | 13.86 6.30 | 1/2"     | 92.0           | 6.1              | 1/2"      |
| NC-8266S   | 1"           | 1-3/8"(35)    | 200-1800(272-2448) | 2300 3118  | 4500       | 7.5(212)             | 90(6.3)      | 16-7/8"(430)     | 13.2 6.0   | 1/2"     | 92             | 6.1              | 1/2"      |
| NC-8266S-6 | 1"           | 1-3/8"(35)    | 200-1800(272-2448) | 2300 3118  | 4500       | 7.5(212)             | 90(6.3)      | 22-3/4"(580)     | 15.84 7.3  | 1/2"     | 92             | 6.1              | 1/2"      |
| NC-8266S-8 | 1"           | 1-3/8"(35)    | 200-1800(272-2448) | 2300 3118  | 4500       | 7.5(212)             | 90(6.3)      | 24-3/4"(630)     | 16.28 7.4  | 1/2"     | 92             | 6.1              | 1/2"      |
| NC-8311    | 1"           | 1-3/8"(33)    | 200-1600(271-2170) | 1800 2441  | 4000       | 11.5(325)            | 90(6.3)      | 15"(38)          | 24.0 10.9  | 1/2"     | 101            | 7.3              | 1/2"      |
| NC-8351    | 1"           | 1-3/8"(33)    | 200-1600(271-2170) | 1800 2441  | 4000       | 11.5(325)            | 90(6.3)      | 20"(510)         | 27.6 12.5  | 1/2"     | 101            | 7.3              | 1/2"      |
| NC-8322    | 1"           | 1-7/16"(36)   | 200-2000(271-2710) | 2500 3390  | 3300       | 11.0(311)            | 90(6.3)      | 17-5/16"(440)    | 34.2 15.5  | 1/2"     | 93.9           | 8.8              | 1/2"      |
| NC-8342    | 1"           | 1-7/16"(36)   | 200-2000(271-2710) | 2500 3390  | 3300       | 11.0(311)            | 90(6.3)      | 24-3/8"(619)     | 38.0 17.3  | 1/2"     | 93.9           | 8.8              | 1/2"      |
| NC-8331    | 1"           | 1-3/8"(35)    | 200-2000(271-2711) | 2000 2711  | 4800       | 9.0(255)             | 90(6.3)      | 13-5/8"(346)     | 16.53 7.5  | 1/2"     | 107            | 10.5             | 1/2"      |
| NC-8331-6  | 1"           | 1-3/8"(35)    | 200-2000(271-2711) | 2000 2711  | 4800       | 9.0(255)             | 90(6.3)      | 18-1/2"(473)     | 18.48 8.4  | 1/2"     | 107            | 10.5             | 1/2"      |
| NC-8332X   | 1"           | 1-3/8"(25)    | 200-2000(271-2710) | 2500 3390  | 4000       | 8.0(226.5)           | 90(6.3)      | 14-11/16"(372.6) | 20.7 9.4   | 3/8"     | 103.8          | 8.22             | 1/2"      |
| NC-8332X-6 | 1"           | 1-3/8"(25)    | 200-2000(271-2710) | 2500 3390  | 4000       | 8.0(226.5)           | 90(6.3)      | 14-11/16"(372.6) | 23.3 10.0  | 3/8"     | 103.8          | 8.22             | 1/2"      |
| NC-8343    | 1"           | 1-3/8"(33)    | 200-1600(271-2170) | 1800 2441  | 3900       | 11.5(325)            | 90(6.3)      | 15"(381)         | 27.7 12.5  | 1/2"     | 103            | 6.3              | 1/2"      |
| NC-8343-8  | 1"           | 1-3/8"(33)    | 200-1600(271-2170) | 1800 2441  | 3900       | 11.5(325)            | 90(6.3)      | 23"(590)         | 30.6 13.9  | 1/2"     | 103            | 6.3              | 1/2"      |
| NC-8362    | 1"           | 1-7/16"(36)   | 200-2000(271-2170) | 2500 3390  | 3700       | 11.0(284)            | 90(6.3)      | 17-7/8"(455)     | 35.2 16.0  | 1/2"     | 93.9           | 8.8              | 1/2"      |
| NC-8372    | 1"           | 1-7/16"(36)   | 200-2000(271-2170) | 2500 3390  | 3700       | 11.0(284)            | 90(6.3)      | 24-7/32"(615)    | 38.7 17.6  | 1/2"     | 93.9           | 8.8              | 1/2"      |
| NC-8382    | 1"           | 1-9/16"(40)   | 200-2000(271-2710) | 2500 3390  | 5000       | 15.9(450)            | 90(6.3)      | 14-17/32"(370)   | 22.0 11.0  | 1/2"     | 100.0          | 6.4              | 1/2"      |
| NC-8382-8  | 1"           | 1-9/16"(40)   | 200-2000(271-2710) | 2500 3390  | 5000       | 15.9(450)            | 90(6.3)      | 22-15/32"(570)   | 27.5 12.5  | 1/2"     | 100.0          | 6.4              | 1/2"      |
| NC-9223    | 1-1/2"       | 2"(50)        | 200-3000(271-4065) | 3500 4746  | 3000       | 16.0(453)            | 90(6.3)      | 17-3/4"(450)     | 43.2 19.7  | 3/4"     | 104.5          | 8.8              | 1/2"      |
| NC-9243    | 1-1/2"       | 2"(50)        | 200-3000(271-4065) | 3500 4746  | 3000       | 16.0(453)            | 90(6.3)      | 24-1/4"(616)     | 50.2 22.8  | 3/4"     | 104.5          | 8.8              | 1/2"      |

# AIR IMPACT WRENCH

## NC-0415-KIT

1/2" DRIVE

5 pieces in one carton

Contents 15 pcs

- 1pc - 1/2" Air Impact Wrench
- 10pcs - Impact sockets, 6 points, standard length 9, 10, 11, 13, 14, 17, 19, 22, 24, 27 mm
- 1pc - Extension bar 5"
- 1pc - Allen Key : 4mm
- 1pc - Mini Oiler 1/4" female x 1/4" male
- 1pc - 1/4" plug



NC-0415M3  
NC-4277



NC-0415M4  
NC-4213



NC-0415M6  
NC-4217



NC-0415M9  
NC-4256Q

## NC-0425-KIT

1/2" DRIVE

5 pieces in one carton

Contents 15 pcs

- 1pc - 1/2" Air Impact Wrench
- 10pcs - Impact sockets, 6 points, standard length 9, 10, 11, 13, 14, 17, 19, 22, 24, 27 mm
- 1pc - Extension bar 5"
- 1pc - Allen Key : 4mm
- 1pc - Mini Oiler 1/4" female x 1/4" male
- 1pc - 1/4" plug



NC-0425M3  
NC-4258



NC-0425M4  
NC-4230



NC-0425M5  
NC-4233



NC-0425M6  
NC-4255Q

## NC-0615-KIT

3/4" DRIVE

2 pieces in one carton

Contents 15 pcs

- 1pc - 3/4" Air Impact Wrench
- 8pcs - Impact sockets, 6 points, standard length 26, 27, 29, 30, 32, 35, 36, 38 mm
- 1pc - Extension bar 7"
- 1pc - Universal Joint
- 2pcs - Allen Key : 4mm, 5mm
- 1pc - Mini Oiler 1/4" - 6113, 6215, 3/8" - 6216
- 1pc - 1/4" plug - 6113, 6215, 3/8" plug - 6216
- 1pc - O-Ring&Pin



NC-0615M0  
NC-6113



NC-0615M1  
NC-6216



NC-0615M2  
NC-6215

## NC-4232Q-KIT

1/2" DRIVE

5 pieces in one carton

Contents 11 pcs

- 1pc - 1/2" Air Impact Wrench
- 7pcs - Impact sockets, MA411M13, 17, 19, 21, 22, 24, 27
- 1pc - 5" Extension bar
- 1pc - Mini Lubricator SW-12
- 1pc - 1/4" plug



## NC-4255Q KIT

1/2" DRIVE

5 pieces in one carton

Contents 11 pcs

- 1pc - 1/2" Air Impact Wrench
- 7pcs - Impact sockets, MA411M13, 17, 19, 21, 22, 24, 27
- 1pc - 5" Extension bar
- 1pc - Mini Lubricator SW-12
- 1pc - 1/4" plug



## NC-4233Q-KIT

1/2" DRIVE

5 pieces in one carton

Contents 11 pcs

- 1pc - Air Impact Wrench
- 5pcs - Impact sockets MA411M13, 17, 19, 21, 22, 24, 27
- 1pc - 5" Extension bar
- 1pc - Mini Lubricator SW-12
- 1pc - 1/4" plug



## NC-4255QH-KIT

1/2" DRIVE

5 pieces in one carton

Contents 11 pcs

- 1pc - 1/2" Air Impact Wrench
- 7pcs - Impact sockets, MA411M13L, 17L, 19L, 21L, 22L, 24L, 27L
- 1pc - 5" Extension bar
- 1pc - Mini Lubricator SW-12
- 1pc - 1/4" plug



## NC-4255Q-41-KIT

1/2" DRIVE

2 pieces in one carton

Contents 41 pcs

- 1pc - Torque wrench : 42-210 Nm (TE-442210N)
- 3pcs - Thin wall impact socket : 17, 19, 21 mm
- 13pcs - Impact deep socket : 10, 11, 12, 13, 14, 15, 16, 17, 18, 19, 21, 22, 24 mm
- 16pcs - impact socket : 10, 11, 12, 13, 14, 15, 16, 17, 18, 19, 21, 22, 24, 27, 30, 32 mm
- 1pc - Air impact wrench : Max torque 1627 Nm / 1200 FT-LB (NC-4255Q)
- 2pcs - Extension bar : 75 mm, 125 mm (ME421-05 / ME421-03)
- 1pc - Universal joint : 1/2" drive (ME4711)
- 1pc - Air blow gun : 250 mm (JC-310)
- 1pc - Mini lubricator : 1/4" drive (SW-12)
- 2pcs - Air adapter : 1/4" plug



Can be customized

## NC-4650-KIT

1/2" DRIVE

5 pieces in one carton

### Contents 11 pcs

- 1pc - 1/2 Air Impact Wrench
- 7pcs - Impact sockets, MA411M13, 17, 19, 21, 22, 24, 27
- 1pc - 5" Extension bar
- 1pc - Mini Lubricator SW-12
- 1pc - 1/4" plug



## NC-4600-KIT NC-4600-14 KIT

1/2" DRIVE

6 pieces in one carton

### Contents 13 pcs

- 1pc - Air Impact Wrench
- 2pcs - Square Head Drive : 3/8" & 1/2"
- 1pc - Lubricating Oil
- 1pc - Release Pin
- 4pcs - Impact Socket : 13, 17, 19, 21 mm
- 1pc - Impact Extension Bar : 14 mm
- 2pcs - Bit Holder : 8 mm & 10 mm
- 1pc - 12 mm Hex Bit
- 1pc - T60 Torx



## NC-6236-KIT NC-6236Q-KIT

3/4" DRIVE

5 pieces in one carton

### Contents 11 pcs

- 1pc - 3/4" Air Impact Wrench
- 7pcs - Impact sockets, MA611M24, 27, 30, 32, 33, 34, 36
- 1pc - Extension bar
- 1pc - Mini Lubricator SW-12
- 1pc - 1/4" plug



## NC-6255Q-KIT

3/4" DRIVE

2 pieces in one carton

### Contents 11 pcs

- 1pc - 3/4" Air Impact Wrench
- 7pcs - Impact sockets, MA611M24, 27, 30, 32, 33, 34, 36
- 1pc - Extension bar
- 1pc - Mini Lubricator SW-12
- 1pc - 1/4" plug



## NEW PRODUCT

## NC-4670Q

1/2" DRIVE Jumbo hammer type



8 pieces in one carton



**SIDE TO SIDE**  
**1.1 KG**  
**650 FT-LB**



| Item No. | Square Drive | Bolt Capacity | Torque Range     |  | Max Torque |     | Free Speed | Avg. Air Consumption | Air Pressure | Overall Length | Net Weight |     | Air Hose | Sound Pressure | Vibration Level  | Air Inlet |
|----------|--------------|---------------|------------------|--|------------|-----|------------|----------------------|--------------|----------------|------------|-----|----------|----------------|------------------|-----------|
|          | Inch         | Inch (mm)     | FT-LB (Nm)       |  | FT-LB      | Nm  | R.P.M      | CFM (L/min)          | PSI (bar)    | Inch (mm)      | LBS        | kg  | Inch     | dBA            | m/s <sup>2</sup> | Inch      |
| NC-4670Q | 1/2"         | 5/8"(16)      | 150-500(204-680) |  | 650        | 884 | 9000       | 5.2(147)             | 90(6.3)      | 4"(105)        | 2.4        | 1.1 | 3/8"     | 85.0           | 3.3              | 1/4"      |

# AIR RATCHET WRENCH

## NE-251/NE-351/NE-451

1/4" & 3/8" & 1/2" DRIVE



20 pieces in one carton



## NE-251R/NE-351R/NE-451R

1/4" & 3/8" & 1/2" DRIVE



20 pieces in one carton



*Rubber handle*

## NE-261/NE-361

1/4" & 3/8" DRIVE



20 pieces in one carton



## NE-2803/NE-3803

1/4" & 3/8" DRIVE



20 pieces in one carton



## NE-2905

1/4" DRIVE



20 pieces in one carton



## NE-321/NE-421

3/8" & 1/2" DRIVE



10 pieces in one carton



## NE-3305/NE-4305

3/8" & 1/2" DRIVE



10 pieces in one carton



5"(127mm) extended

## NE-3310/NE-4310

3/8" & 1/2" DRIVE



6 pieces in one carton



## NE-332/NE-432

3/8" & 1/2" DRIVE



10 pieces in one carton



## NE-332T/NE-432T

3/8" & 1/2" DRIVE



10 pieces in one carton

• Two step trigger



## NE-343/NE-443

3/8" & 1/2" DRIVE



10 pieces in one carton



## NE-352

3/8" DRIVE 2 in 1



20 pieces in one carton



## NE-362

3/8" DRIVE 2 in 1



20 pieces in one carton



## NE-3808/NE-4808

3/8" & 1/2" DRIVE



10 pieces in one carton



## NE-383/NE-483

3/8" & 1/2" DRIVE



10 pieces in one carton

• Two step trigger



Stylized grip

## NE-4901

1/2" DRIVE



20 pieces in one carton



| Item No. | Square Drive | Torque Range   |       | Max Torque |       | Free Speed  | Avg. Air Consumption | Air Pressure   | Overall Length | Net Weight |      | Air Hose | Sound Pressure   | Vibration Level | Air Inlet |
|----------|--------------|----------------|-------|------------|-------|-------------|----------------------|----------------|----------------|------------|------|----------|------------------|-----------------|-----------|
|          | Inch         | FT-LB (Nm)     | FT-LB | Nm         | R.P.M | CFM (L/min) | PSI (bar)            | Inch (mm)      | LBS            | kg         | Inch | dBA      | m/s <sup>2</sup> | Inch            |           |
| NE-251   | 1/4"         | 5-15(6.7-20)   | 22    | 30         | 350   | 3.0(84.96)  | 90(6.3)              | 5"(125)        | 1.1            | 0.50       | 3/8" | 89.0     | 4.4              | 1/4"            |           |
| NE-351   | 3/8"         | 5-15(6.7-20)   | 22    | 30         | 350   | 3.0(84.96)  | 90(6.3)              | 5"(125)        | 1.1            | 0.50       | 3/8" | 89.0     | 4.4              | 1/4"            |           |
| NE-451   | 1/2"         | 5-20(6.7-27)   | 25    | 33.9       | 350   | 3.0(84.96)  | 90(6.3)              | 5"(125)        | 1.1            | 0.50       | 3/8" | 89.0     | 4.4              | 1/4"            |           |
| NE-251R  | 1/4"         | 5-15(6.7-20)   | 22    | 30         | 350   | 3.0(84.96)  | 90(6.3)              | 5"(125)        | 1.1            | 0.50       | 3/8" | 89.0     | 4.4              | 1/4"            |           |
| NE-351R  | 3/8"         | 5-15(6.7-20)   | 22    | 30         | 350   | 3.0(84.96)  | 90(6.3)              | 5"(125)        | 1.1            | 0.50       | 3/8" | 89.0     | 4.4              | 1/4"            |           |
| NE-451R  | 1/2"         | 5-20(6.7-27)   | 25    | 33.9       | 350   | 3.0(84.96)  | 90(6.3)              | 5"(125)        | 1.1            | 0.50       | 3/8" | 89.0     | 4.4              | 1/4"            |           |
| NE-261   | 1/4"         | 10-35(13.5-47) | 37    | 50         | 230   | 4.0(130)    | 90(6.3)              | 6-5/16"(160)   | 1.1            | 0.50       | 3/8" | 88.0     | 3.0              | 1/4"            |           |
| NE-361   | 3/8"         | 10-35(13.5-47) | 37    | 50         | 230   | 4.0(130)    | 90(6.3)              | 6-5/16"(160)   | 1.1            | 0.50       | 3/8" | 88.0     | 3.0              | 1/4"            |           |
| NE-2803  | 1/4"         | 5-15(7-20)     | 35    | 47.6       | 300   | 3.6(102)    | 90(6.3)              | 8-1/2"(220)    | 1.39           | 0.63       | 3/8" | 92.8     | 3.2              | 1/4"            |           |
| NE-3803  | 3/8"         | 5-30(7-40)     | 35    | 47.6       | 300   | 3.6(102)    | 90(6.3)              | 8-1/2"(220)    | 1.39           | 0.63       | 3/8" | 92.0     | 3.2              | 1/4"            |           |
| NE-2905  | 1/4"         | 5-15(7-20)     | 22    | 30         | 300   | 3.0(85)     | 90(6.3)              | 11-1/2"(290)   | 1.85           | 0.84       | 3/8" | 89.0     | 4.4              | 1/4"            |           |
| NE-321   | 3/8"         | 10-35(13.5-47) | 50    | 68         | 160   | 4.0(113.28) | 90(6.3)              | 10-3/8"(265)   | 2.3            | 1.04       | 3/8" | 91.0     | 3.9              | 1/4"            |           |
| NE-421   | 1/2"         | 10-35(13.5-47) | 50    | 68         | 160   | 4.0(113.28) | 90(6.3)              | 10-3/8"(265)   | 2.3            | 1.04       | 3/8" | 92.8     | 4.6              | 1/4"            |           |
| NE-3305  | 3/8"         | 15-55(20-75)   | 70    | 95         | 160   | 5(142)      | 90(6.3)              | 15-3/8"(390)   | 3.52           | 1.6        | 3/8" | 82       | 1.2              | 1/4"            |           |
| NE-4305  | 1/2"         | 15-55(20-75)   | 70    | 95         | 160   | 5(142)      | 90(6.3)              | 15-3/8"(390)   | 3.52           | 1.6        | 3/8" | 82       | 1.2              | 1/4"            |           |
| NE-3310  | 3/8"         | 15-55(20-75)   | 70    | 95         | 160   | 4.0(113)    | 90(6.3)              | 20-7/8"(530)   | 3.85           | 1.75       | 3/8" | 82       | 1.2              | 1/4"            |           |
| NE-4310  | 1/2"         | 15-55(20-75)   | 70    | 95         | 160   | 4.0(113)    | 90(6.3)              | 20-7/8"(530)   | 3.85           | 1.75       | 3/8" | 82       | 1.2              | 1/4"            |           |
| NE-332   | 3/8"         | 10-45(13.5-61) | 60    | 81         | 160   | 4.0(113.28) | 90(6.3)              | 10-3/8"(265)   | 3.6            | 1.22       | 3/8" | 90.5     | 4.4              | 1/4"            |           |
| NE-432   | 1/2"         | 10-45(13.5-61) | 60    | 81         | 160   | 4.0(113.28) | 90(6.3)              | 10-3/8"(265)   | 3.6            | 1.22       | 3/8" | 89.8     | 5.2              | 1/4"            |           |
| NE-332T  | 3/8"         | 10-45(13.5-61) | 60    | 81         | 160   | 4.0(113.28) | 90(6.3)              | 10-3/8"(265)   | 3.6            | 1.22       | 3/8" | 90.5     | 4.4              | 1/4"            |           |
| NE-432T  | 1/2"         | 10-45(13.5-61) | 60    | 81         | 160   | 4.0(113.28) | 90(6.3)              | 10-3/8"(265)   | 3.6            | 1.22       | 3/8" | 89.8     | 5.2              | 1/4"            |           |
| NE-343   | 3/8"         | 10-55(13.5-74) | 75    | 101.7      | 160   | 4.0(113.28) | 90(6.3)              | 11"(280)       | 2.8            | 1.30       | 3/8" | 84.0     | 4.4              | 1/4"            |           |
| NE-443   | 1/2"         | 10-55(13.5-74) | 100   | 135.6      | 160   | 4.0(113.28) | 90(6.3)              | 11"(280)       | 2.8            | 1.30       | 3/8" | 84.0     | 4.4              | 1/4"            |           |
| NE-352   | 3/8"         | 5-15(6.7-20)   | 22    | 30         | 350   | 3.0(84.96)  | 90(6.3)              | 5"(125)        | 1.1            | 0.50       | 3/8" | 89.0     | 4.4              | 1/4"            |           |
| NE-362   | 3/8"         | 10-35(13.5-47) | 37    | 50         | 230   | 4.6(130)    | 90(6.3)              | 6-5/16"(160)   | 1.1            | 0.50       | 3/8" | 89.0     | 3.0              | 1/4"            |           |
| NE-3808  | 3/8"         | 10-55(13.5-74) | 80    | 108.8      | 180   | 4.0(113)    | 90(6.3)              | 12"(300)       | 2.77           | 1.26       | 3/8" | 95.0     | 3.6              | 1/4"            |           |
| NE-4808  | 1/2"         | 10-55(13.5-74) | 80    | 108.8      | 180   | 4.0(113.28) | 90(6.3)              | 12"(280)       | 2.77           | 1.26       | 3/8" | 95.0     | 3.6              | 1/4"            |           |
| NE-383   | 3/8"         | 15-65(13.5-88) | 100   | 135.6      | 250   | 5.0(141)    | 90(6.3)              | 10-29/32"(277) | 2.82           | 1.28       | 3/8" | 85       | 2.0              | 1/4"            |           |
| NE-483   | 1/2"         | 15-65(13.5-88) | 100   | 135.6      | 250   | 5.0(141)    | 90(6.3)              | 10-29/32"(277) | 2.82           | 1.28       | 3/8" | 85       | 2.0              | 1/4"            |           |
| NE-4901  | 1/2"         | 10-40(13.5-54) | 50    | 68         | 1100  | 3.0(85)     | 90(6.3)              | 6-1/4"(159)    | 1.48           | 0.67       | 3/8" | 89.0     | 2.2              | 1/4"            |           |

# AIR RATCHET WRENCH



## NE-399/NE-499

3/8" & 1/2" DRIVE Jumbo hammer type



8 pieces in one carton



## NE-499N

1/2" DRIVE



8 pieces in one carton

- 1pc - Air Angle Impact Ratchet (NE-499)
- Stubby impact sockets, 6 points :
- 9pcs - 9, 10, 11, 13, 14, 17, 19, 22, 24 mm
- 1pc - 1/4" plug



| Item No. | Square Drive |           | Torque Range   |       | Max Torque |       | Free Speed  | Avg. Air Consumption | Air Pressure | Overall Length | Net Weight |      | Air Hose | Sound Pressure   | Vibration Level | Air Inlet |
|----------|--------------|-----------|----------------|-------|------------|-------|-------------|----------------------|--------------|----------------|------------|------|----------|------------------|-----------------|-----------|
|          | Inch         | Inch (mm) | FT-LB (Nm)     | FT-LB | Nm         | R.P.M | CFM (L/min) | PSI (bar)            | Inch (mm)    | LBS            | kg         | Inch | dBA      | m/s <sup>2</sup> | Inch            |           |
| NE-399   | 3/8"         | 3/8"(13)  | 50-130(68-176) | 180   | 244        | 7500  | 2.45(69.4)  | 90(6.3)              | 13-3/8"(340) | 4.0            | 1.83       | 3/8" | 93.0     | 9.9              | 1/4"            |           |
| NE-499   | 1/2"         | 9/16"(14) | 50-130(68-176) | 250   | 339        | 7500  | 2.45(69.4)  | 90(6.3)              | 13-3/8"(340) | 4.0            | 1.83       | 3/8" | 93.0     | 9.9              | 1/4"            |           |

## NE-462

1/2" DRIVE Pin clutch type



10 pieces in one carton



## NE-462T

1/2" DRIVE Pin clutch type



10 pieces in one carton



Stylized grip

## NE-4815

1/2" DRIVE



10 pieces in one carton

- 360° Swivel exhaust



## NE-488

1/2" DRIVE



12 pieces in one carton



| Item No. | Square Drive |                | Torque Range |       | Max Torque |             | Free Speed | Avg. Air Consumption | Air Pressure | Overall Length | Net Weight |      | Air Hose         | Sound Pressure | Vibration Level | Air Inlet |
|----------|--------------|----------------|--------------|-------|------------|-------------|------------|----------------------|--------------|----------------|------------|------|------------------|----------------|-----------------|-----------|
|          | Inch         | FT-LB (Nm)     | FT-LB        | Nm    | R.P.M      | CFM (L/min) | PSI (bar)  | Inch (mm)            | LBS          | kg             | Inch       | dBA  | m/s <sup>2</sup> | Inch           |                 |           |
| NE-462   | 1/2"         | 10-55(13.5-74) | 74           | 100   | 200        | 4.0(113.28) | 90(6.3)    | 13"(330)             | 4.1          | 1.88           | 3/8"       | 84.0 | 2.5              | 1/4"           |                 |           |
| NE-462T  | 1/2"         | 10-65(13.5-88) | 100          | 135.6 | 200        | 5.0(141)    | 90(6.3)    | 13-13/32"(340)       | 4.0          | 1.83           | 3/8"       | 85.0 | 2.2              | 1/4"           |                 |           |
| NE-4815  | 1/2"         | 40-120(54-163) | 150          | 204   | 170        | 4.8(136)    | 90(6.3)    | 12-1/4"(313)         | 3.39         | 1.54           | 3/8"       | 93   | 2.5              | 1/4"           |                 |           |
| NE-488   | 1/2"         | 10-40(13.5-54) | 60           | 81    | 150        | 4.5(127.4)  | 90(6.3)    | 10-13/16"(275)       | 3.2          | 1.45           | 3/8"       | 85.0 | 3.9              | 1/4"           |                 |           |

## NE-0357

3/8" DRIVE



10 pieces in one carton

- 1pc - Air Ratchet Wrench (NE-352)
- 7pcs - 1/4" Dr. socket : 4, 5, 6, 7, 8, 9, 10 mm
- 6pcs - 3/8" Dr. socket : 11, 12, 13, 14, 15, 17 mm
- 40pcs - 1/4" Bits
- 1pc - 3/8" Extension Bar
- 1pc - 1/4" Hex Size shank driver
- 1pc - Plug

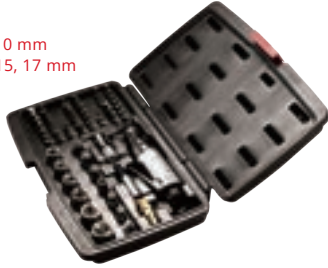

## NE-0413 KIT NE-0413S KIT

1/2" DRIVE



6 pieces in one carton

- 1pc - Air Ratchet Wrench (NE-461)
- 8pcs - 3/4" Hex Thru-hole socket : 8, 9, 10, 12, 13, 14, 17, 19 mm (NE-0413)
- 8pcs - 3/4" Hex Thru-hole socket : 5/16", 3/8", 7/16", 1/2", 9/16", 5/8", 11/16", 3/4" (NE-0413S)
- 1pc - 3" Extension Bar
- 2pcs - 1/2" 3/8" Adapter
- 1pc - Plug



| Item No. | Square Drive | Bolt Capacity | Torque Range   | Max Torque |     | Free Speed | Avg. Air Consumption | Air Pressure | Overall Length | Net Weight |      | Air Hose | Sound Pressure | Vibration Level  | Air Inlet |
|----------|--------------|---------------|----------------|------------|-----|------------|----------------------|--------------|----------------|------------|------|----------|----------------|------------------|-----------|
|          | Inch         | Inch (mm)     | FT-LB (Nm)     | FT-LB      | Nm  | R.P.M      | CFM (L/min)          | PSI (bar)    | Inch (mm)      | LBS        | kg   | Inch     | dBA            | m/s <sup>2</sup> | Inch      |
| NE-352   | 3/8"         | 9/16"(14)     | 5-15(6.7-20)   | 22         | 30  | 350        | 3.0(84.96)           | 90(6.3)      | 5"(125)        | 1.1        | 0.50 | 3/8"     | 89.0           | 4.4              | 1/4"      |
| NE-461   | 1/2"         | 9/16"(14)     | 10-65(13.5-88) | 100        | 135 | 180        | 4.0(113)             | 90(6.3)      | 10-3/8"(270)   | 2.6        | 1.20 | 3/8"     | 83.0           | 2.3              | 1/4"      |

## NE-0405 KIT

1/2" DRIVE 5 IN 1 MULTIPLE TOOL KIT



5 pieces in one carton

- 1pc - NE-9004
- 1pc - QA-9120
- 1pc - QA-9620
- 1pc - QB-9903
- 1pc - QE-2132



60 FT-LB / 81 Nm



• Ratchet NE-9004 1pc



• Air drill QE-2132 1pc



• Angle Grinder QB-9903



• Die Grinder QA-9120



• Angle Die Grinder QA-9620

| Item No. | Cylinder Power | Chuck Capacity     | Free Speed | Avg. Air Consumption | Air Pressure | Overall Length | Net Weight | Air Hose | Sound Pressure | Air Inlet |
|----------|----------------|--------------------|------------|----------------------|--------------|----------------|------------|----------|----------------|-----------|
|          | hp(w)          | Inch (mm)          | R.P.M      | CFM (L/min)          | PSI (bar)    | Inch (mm)      | kg         | Inch     | dBA            | Inch      |
| NE-9004  | 0.5(372)       | 1/2"(13)           | 150        | 5                    | 90(6.3)      | 287            | 1.488      | 3/8"     | 82             | 1/4"      |
| QA-9120  | 0.5(372)       | 1/4" & 1/8"(6 & 3) | 20000      | 5                    | 90(6.3)      | 202            | 0.73       | 3/8"     | 82             | 1/4"      |
| QA-9620  | 0.5(372)       | 1/4" & 1/8"(6 & 3) | 14000      | 5                    | 90(6.3)      | 208            | 0.89       | 3/8"     | 82             | 1/4"      |
| QB-9903  | 0.5(372)       | PAD DIA 3"(76)     | 14000      | 5                    | 90(6.3)      | 211            | 0.976      | 3/8"     | 82             | 1/4"      |
| QE-2132  | 0.5(372)       | 3/8"(10)           | 2500       | 5                    | 90(6.3)      | 248            | 1.143      | 3/8"     | 82             | 1/4"      |

## NEW PRODUCT

## NE-2900/NE-3900

1/4" & 3/8" DRIVE



20 pieces in one carton



NO KICK!!



Exhaust



### FEATURES

- No force is generated when used.
- Extremely small body that can be grasped with one hand.
- Compact size allows for greater access to tight spaces.
- Lightweight design reduces fatigue.

| Item No. | Square Drive | Torque Range   | Max Torque |      | Free Speed | Avg. Air Consumption | Air Pressure | Overall Length | Net Weight |      | Air Hose | Sound Pressure | Vibration Level  | Air Inlet |
|----------|--------------|----------------|------------|------|------------|----------------------|--------------|----------------|------------|------|----------|----------------|------------------|-----------|
|          | Inch         | FT-LB (Nm)     | FT-LB      | Nm   | R.P.M      | CFM (L/min)          | PSI (bar)    | Inch (mm)      | LBS        | kg   | Inch     | dBA            | m/s <sup>2</sup> | Inch      |
| NE-2900  | 1/4"         | 5-35(7.0-47.0) | 40         | 54.0 | 1000       | 3.4(96)              | 90(6.3)      | 6-1/4"(160)    | 1.43       | 0.65 | 3/8"     | 80.0           | 2.3              | 1/4"      |
| NE-3900  | 3/8"         | 5-35(7.0-47.0) | 40         | 54.0 | 1000       | 3.4(96)              | 90(6.3)      | 6-1/4"(160)    | 1.43       | 0.65 | 3/8"     | 80.0           | 2.3              | 1/4"      |



# AIR DIE GRINDER

## QA-101 A/B

AIR DIE GRINDER



20 pieces in one carton

**Mighty Mini**  
119 mm



## QA-110 A/B

AIR DIE GRINDER



20 pieces in one carton

*Stylized grip*



## QA-111 A/B

AIR DIE GRINDER



20 pieces in one carton



## QA-116 A/B

AIR DIE GRINDER



10 pieces in one carton

*Stylized grip*



## QA-1211/QA-1221 A/B QA-2211/QA-2221 A/B

AIR DIE GRINDER Safety lever type throttle



20 pieces in one carton

QA-1211 / QA-1221



QA-2211 / QA-2221



## QA-141 A/B QA-141L A/B

AIR DIE GRINDER



20 pieces in one carton

- QA-141-Roll type throttle
- QA-141L-Lever type throttle



QA-141



QA-141L

## QA-131 A/B

AIR DIE GRINDER Roll type throttle



20 pieces in one carton



## QA-143 A/B

AIR DIE GRINDER Roll type throttle



12 pieces in one carton



## QA-151 A/B

AIR DIE GRINDER Roll type throttle



20 pieces in one carton



## QA-163 A/B QA-163L A/B

AIR DIE GRINDER



12 pieces in one carton

- QA-163-Roll type throttle
- QA-163L-Lever type throttle



QA-163

QA-163L

## QA-1710 A/B

### EXTENDED AIR DIE GRINDER



10 pieces in one carton



## QA-210 A/B

### AIR DIE GRINDER



20 pieces in one carton

Keyless Collet



## QA-211 A/B

### AIR DIE GRINDER



20 pieces in one carton



## QA-231Q A/B

### AIR DIE GRINDER



20 pieces in one carton



## QA-241 A/B

### AIR DIE GRINDER



20 pieces in one carton



| Item No. | Collet Size | Collet Size | Free Speed | Avg. Air Consumption | Air Pressure | Overall Length | Motor | Net Weight |      | Air Hose | Sound Pressure | Vibration Level  | Air Inlet |
|----------|-------------|-------------|------------|----------------------|--------------|----------------|-------|------------|------|----------|----------------|------------------|-----------|
|          | A mm        | B inch      | R.P.M      | CFM (L/min)          | PSI (bar)    | Inch (mm)      | HP    | LBS        | kg   | Inch     | dBA            | m/s <sup>2</sup> | Inch      |
| QA-101   | 6 & 3       | 1/4" & 1/8" | 25000      | 6.3(178)             | 90(6.3)      | 4-11/16"(119)  | 0.3   | 0.71       | 0.32 | 3/8"     | 80.0           | 1.4              | 1/4"      |
| QA-110   | 6 & 3       | 1/4" & 1/8" | 22000      | 5.0(141)             | 90(6.3)      | 7-5/16"(186)   | 0.5   | 1.36       | 0.62 | 3/8"     | 85.0           | 1.1              | 1/4"      |
| QA-111   | 6 & 3       | 1/4" & 1/8" | 25000      | 10.0(283)            | 90(6.3)      | 6"(155)        | 0.3   | 0.8        | 0.38 | 3/8"     | 81.5           | 1.8              | 1/4"      |
| QA-116   | 6 & 3       | 1/4" & 1/8" | 22000      | 5.0(141)             | 90(6.3)      | 13-9/16"(345)  | 0.5   | 2.53       | 1.15 | 3/8"     | 85.0           | 1.8              | 1/4"      |
| QA-1211  | 3           | 1/8"        | 25000      | 14                   | 90(6.3)      | 7-11/16"(196)  | 0.4   | 1.1        | 0.49 | 3/8"     | 68             | 0.9              | 1/4"      |
| QA-1221  | 6           | 1/4"        | 25000      | 14                   | 90(6.3)      | 7-11/16"(196)  | 0.4   | 1.1        | 0.49 | 3/8"     | 68             | 0.9              | 1/4"      |
| QA-2211  | 3           | 1/8"        | 20000      | 14                   | 90(6.3)      | 8-7/16"(215)   | 0.6   | 1.6        | 0.71 | 3/8"     | 75             | 0.9              | 1/4"      |
| QA-2221  | 6           | 1/4"        | 20000      | 14                   | 90(6.3)      | 8-7/16"(215)   | 0.6   | 1.6        | 0.71 | 3/8"     | 75             | 0.9              | 1/4"      |
| QA-131   | 3           | 1/8"        | 30000      | 14.0(396)            | 90(6.3)      | 6-11/16"(170)  | 0.4   | 1.3        | 0.60 | 3/8"     | 75.0           | 2.5              | 1/4"      |
| QA-141   | 6           | 1/4"        | 24000      | 14.0(396)            | 90(6.3)      | 6-11/16"(170)  | 0.4   | 1.3        | 0.60 | 3/8"     | 75.0           | 2.5              | 1/4"      |
| QA-141L  | 6           | 1/4"        | 24000      | 14.0(396)            | 90(6.3)      | 6-11/16"(170)  | 0.4   | 1.3        | 0.60 | 3/8"     | 75.0           | 2.5              | 1/4"      |
| QA-143   | 6           | 1/4"        | 24000      | 14.0(396)            | 90(6.3)      | 11-11/16"(296) | 0.4   | 2.0        | 0.90 | 3/8"     | 75.0           | 2.5              | 1/4"      |
| QA-151   | 6           | 1/4"        | 18000      | 12.2(345)            | 90(6.3)      | 7"(177)        | 0.9   | 1.76       | 0.80 | 3/8"     | 75.0           | 2.1              | 1/4"      |
| QA-163   | 6           | 1/4"        | 16000      | 5.0(141)             | 90(6.3)      | 12"(305)       | 0.9   | 2.7        | 1.25 | 3/8"     | 90.0           | 2.8              | 1/4"      |
| QA-163L  | 6           | 1/4"        | 16000      | 5.0(141)             | 90(6.3)      | 13-25/32"(350) | 0.9   | 2.9        | 1.31 | 3/8"     | 90.0           | 2.8              | 1/4"      |
| QA-1710  | 6           | 1/4"        | 18000      | 5.0(141)             | 90(6.3)      | 18-5/16"(465)  | 0.4   | 2.36       | 1.07 | 3/8"     | 80.0           | 1.5              | 1/4"      |
| QA-210   | 6           | 1/4"        | 20000      | 10.0(283)            | 90(6.3)      | 7-1/2"(190)    | 0.9   | 1.4        | 0.65 | 3/8"     | 75.7           | 0.8              | 1/4"      |
| QA-211   | 6 & 3       | 1/8" & 1/4" | 20000      | 10.0(283)            | 90(6.3)      | 7-1/2"(190)    | 0.9   | 1.4        | 0.65 | 3/8"     | 75.7           | 0.8              | 1/4"      |
| QA-231Q  | 6 & 3       | 1/8" & 1/4" | 20000      | 14.8(420)            | 90(6.3)      | 5-29/32"(150)  | 0.45  | 0.8        | 0.35 | 3/8"     | 80.0           | >2.5             | 1/4"      |
| QA-241   | 6 & 3       | 1/8" & 1/4" | 4000       | 10.6(283)            | 90(6.3)      | 8-5/8"(220)    | 0.5   | 1.6        | 0.75 | 3/8"     | 75.0           | 0.87             | 1/4"      |

# AIR DIE GRINDER

## QA-311 A/B

AIR DIE GRINDER



10 pieces in one carton



## QA-313 A/B

AIR DIE GRINDER



10 pieces in one carton



## QA-315 A/B

AIR DIE GRINDER



10 pieces in one carton



## QA-611 A/B

90° AIR ANGLE DIE GRINDER



20 pieces in one carton



## QA-6205 A/B

EXTENDED 90° AIR ANGLE DIE GRINDER

Safety lever type throttle



20 pieces in one carton



## QA-632Q A/B

97° AIR ANGLE DIE GRINDER



20 pieces in one carton



## QA-633Q A/B

97° AIR ANGLE DIE GRINDER



20 pieces in one carton



## QA-681 A/B

AIR ANGLE DIE GRINDER



10 pieces in one carton



AIR DIE GRINDER

## QA-0115 A/B QA-0215 A/B

**AIR DIE GRINDER 15PCS KIT**



10 pieces in one carton

- 1pc - Air Die Grinder (QA-111 / QA-211)
- 1pc - Collet (3 mm or 1/8")
- 2pcs - Spanner Wrench
- 5pcs - Grinder Stone (3 mm or 1/8")
- 5pcs - Shank Stone (6 mm or 1/4")
- 1pc - Plug (adapter)



## QA-0207 A/B

**AIR DIE GRINDER 7PCS KIT**



10 pieces in one carton

- 1pc - Air Die Grinder (QA-210)
- 5pcs - Shank stone (6mm or 1/4")
- 1pc - Plug (adapter)



## QA-0615 A/B

**AIR DIE GRINDER 15PCS KIT**



10 pieces in one carton

- 1pc - Air Die Grinder(QA-611)
- 1pc - Collet (3 mm or 1/8")
- 2pcs - Spanner Wrench
- 5pcs - Grinder Stone (3 mm or 1/8")
- 5pcs - Shank Stone (6 mm or 1/4")
- 1pc - Plug (adapter)



QA-111



QA-211



QA-210

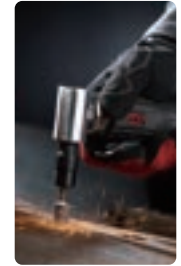

QA-611

| Item No. | Collet Size |             | Free Speed | Avg. Air Consumption | Air Pressure | Overall Length | Motor | Net Weight |             | Air Hose | Sound Pressure | Vibration Level | Air Inlet |
|----------|-------------|-------------|------------|----------------------|--------------|----------------|-------|------------|-------------|----------|----------------|-----------------|-----------|
|          | A mm        | B inch      |            |                      |              |                |       | R.P.M      | CFM (L/min) |          |                |                 |           |
|          |             |             |            |                      |              |                |       |            |             |          |                |                 |           |
| QA-311   | 6 & 3       | 1/4" & 1/8" | 25000      | 10.0(283)            | 90(6.3)      | 7-1/2"(190)    | 0.3   | 1.0        | 0.48        | 3/8"     | 81.5           | 1.8             | 1/4"      |
| QA-313   | 6 & 3       | 1/4" & 1/8" | 25000      | 10.0(283)            | 90(6.3)      | 9-1/4"(235)    | 0.5   | 1.2        | 0.58        | 3/8"     | 81.5           | 1.8             | 1/4"      |
| QA-315   | 6 & 3       | 1/4" & 1/8" | 25000      | 10.0(283)            | 90(6.3)      | 11"(280)       | 0.3   | 1.4        | 0.63        | 3/8"     | 81.5           | 1.8             | 1/4"      |
| QA-611   | 6 & 3       | 1/4" & 1/8" | 19000      | 10.0(283)            | 90(6.3)      | 6-1/8"(160)    | 0.3   | 1.12       | 0.51        | 3/8"     | 74.4           | 1.7             | 1/4"      |
| QA-6205  | 6           | 1/4"        | 14500      | 3.5                  | 90(6.3)      | 12-1/8"(308)   | 0.5   | 2.09       | 0.95        | 3/8"     | ---            | ---             | 1/4"      |
| QA-632Q  | 6 & 3       | 1/4" & 1/8" | 22000      | 12.3(350)            | 90(6.3)      | 7"(177)        | 0.4   | 1.12       | 0.51        | 3/8"     | 75.0           | 2.5             | 1/4"      |
| QA-633Q  | 6 & 3       | 1/4" & 1/8" | 15000      | 17.2(490)            | 90(6.3)      | 7-1/8"(180)    | 0.6   | 1.54       | 0.70        | 3/8"     | 78             | 2.5             | 1/4"      |
| QA-681   | 6 & 3       | 1/4" & 1/8" | 20000      | 5.0(141)             | 90(6.3)      | 7-11/16"(195)  | 0.5   | 1.76       | 0.8         | 3/8"     | 85.0           | 1.8             | 1/4"      |

## NEW PRODUCT

## QA-688

**AIR DIE GRINDER FLEX-HEAD**



10 pieces in one carton



### FEATURES

- Flexible head for accessing hard-to-reach areas.
- Small tool for spot sanding and finishing applications.
- Ideal for automotive aftermarket and light industry.

| Item No. | Collet Size |             | Free Speed | Avg. Air Consumption | Air Pressure | Overall Length | Motor | Net Weight |             | Air Hose | Sound Pressure | Vibration Level | Air Inlet |
|----------|-------------|-------------|------------|----------------------|--------------|----------------|-------|------------|-------------|----------|----------------|-----------------|-----------|
|          | A mm        | B inch      |            |                      |              |                |       | R.P.M      | CFM (L/min) |          |                |                 |           |
|          |             |             |            |                      |              |                |       |            |             |          |                |                 |           |
| QA-688   | 6 & 3       | 1/4" & 1/8" | 20000      | 10(283)              | 90(6.3)      | 7"(178)        | 0.3   | 1.4        | 0.65        | 3/8"     | 80.0           | 1.1             | 1/4"      |

# MICRO AIR DIE GRINDER

## QA-441

**MICRO AIR DIE GRINDER**  
A : 3 mm B : 1/8"



20 pieces in one carton



## QA-412

**MICRO AIR DIE GRINDER**  
A : 3 mm B : 1/8"



20 pieces in one carton



## QA-421

**MICRO AIR DIE GRINDER**  
A : 3 mm B : 1/8"



20 pieces in one carton



## QA-431

**MICRO AIR DIE GRINDER**  
A : 3 mm B : 1/8"



10 pieces in one carton



## QA-432

**MICRO AIR DIE GRINDER**  
A : 3 mm B : 1/8"



20 pieces in one carton



## QA-4507

**MICRO AIR DIE GRINDER**  
A : 6 mm B : 1/4"



10 pieces in one carton



## QA-511

**ENGRAVING PEN**



20 pieces in one carton



| Item No. | Collet Size | Free Speed | Blow Per Minute | Avg. Air Consumption | Air Pressure | Overall Length | Hose Length | Net Weight |      | Air Hose | Sound Pressure | Vibration Level  | Air Inlet |
|----------|-------------|------------|-----------------|----------------------|--------------|----------------|-------------|------------|------|----------|----------------|------------------|-----------|
|          | inch (mm)   | R.P.M      | bpm             | CFM (L/min)          | PSI (bar)    | Inch (mm)      | mm          | LBS        | kg   | Inch     | dBA            | m/s <sup>2</sup> | Inch      |
| QA-441   | 1/8"(3)     | 60000      | ---             | 2.0(56)              | 90(6.3)      | 5-5/16"(135)   | 1500        | 0.40       | 0.18 | 3/8"     | 71.0           | 1.0              | 1/4"      |
| QA-412   | 1/8"(3)     | 60000      | ---             | 2.7(76)              | 90(6.3)      | 6-3/4"(170)    | 1500        | 0.50       | 0.22 | 3/8"     | 70.0           | 0.5              | 1/4"      |
| QA-421   | 1/8"(3)     | 60000      | ---             | 2.7(76)              | 90(6.3)      | 6"(150)        | 1500        | 0.50       | 0.22 | 3/8"     | 70.0           | 0.5              | 1/4"      |
| QA-431   | 1/8"(3)     | 54000      | ---             | 2.0(56)              | 90(6.3)      | 5-3/8"(137)    | 1425        | 0.40       | 0.18 | 3/8"     | 70.0           | 0.5              | 1/4"      |
| QA-432   | 1/8"(3)     | 70000      | ---             | 1.0(29)              | 90(6.3)      | 5-3/8"(137)    | 1425        | 0.40       | 0.18 | 3/8"     | 70.0           | 0.5              | 1/4"      |
| QA-4507  | 1/4"(6)     | 32000      | ---             | 4.0(113)             | 90(6.3)      | 14-11/32"(364) | 1500        | 0.88       | 0.40 | 3/8"     | 85.0           | 1.2              | 1/4"      |
| QA-511   | ---         | ---        | 13000           | 1.0(29)              | 90(6.3)      | 5-1/2"(140)    | 1420        | 0.50       | 0.22 | 3/8"     | 78.0           | 0.6              | 1/4"      |

# AIR ANGLE GRINDER

• Note : The grinding wheel is not supplied along with the tool

## QB-1004

Roll type throttle



6 pieces in one carton



## QB-104X/QB-105X

Roll type throttle



10 pieces in one carton



## QB-114X/QB-115X

Roll type throttle



10 pieces in one carton



## QB-117

Roll type throttle



6 pieces in one carton



## QB-124/QB-125

Roll type throttle



10 pieces in one carton



## QB-134X/QB-135X QB-154X/QB-155X

Roll type throttle



10 pieces in one carton



## QB-144X/QB-145X QB-164X/QB-165X

Roll type throttle



10 pieces in one carton



## QB-177

Roll type throttle



6 pieces in one carton



## QB-179

AIR VERTICAL GRINDER

Lever type throttle



4 pieces in one carton



| Item No. | Pad Dia / Arbor Size | Spindle Size | Free Speed | Avg. Air Consumption | Air Pressure | Overall Length | Motor | Net Weight |      | Air Hose | Sound Pressure | Vibration Level  | Air Inlet |
|----------|----------------------|--------------|------------|----------------------|--------------|----------------|-------|------------|------|----------|----------------|------------------|-----------|
|          | inch(mm)             |              | R.P.M      | CFM (L/min)          | PSI (bar)    | Inch (mm)      | HP    | LBS        | kg   | Inch     | dBA            | m/s <sup>2</sup> | Inch      |
| QB-1004  | 4"(100x16)           | M8x1.25      | 13500      | 4.9(138)             | 90(6.3)      | 7-3/32"(215)   | 0.6   | 2.6        | 1.2  | 3/8"     | 85.0           | 2.5              | 1/4"      |
| QB-104X  | 4"(100x16)           | 3/8"-24      | 11000      | 6.0(170)             | 90(6.3)      | 8-7/8"(226)    | 0.78  | 4.0        | 1.81 | 3/8"     | 87.8           | 1.2              | 1/4"      |
| QB-105X  | 5"(125x22)           | 5/8"-11      | 11000      | 6.0(170)             | 90(6.3)      | 8-7/8"(226)    | 0.78  | 4.0        | 1.81 | 3/8"     | 87.1           | 1.2              | 1/4"      |
| QB-114X  | 4"(100x16)           | 3/8"-24      | 11000      | 6.0(170)             | 90(6.3)      | 9"(230)        | 0.78  | 4.0        | 1.81 | 3/8"     | 87.8           | 1.2              | 1/4"      |
| QB-115X  | 5"(125x22)           | 5/8"-11      | 11000      | 6.0(170)             | 90(6.3)      | 9"(230)        | 0.78  | 4.0        | 1.81 | 3/8"     | 87.1           | 1.2              | 1/4"      |
| QB-117   | 7"(178x22)           | ---          | 7000       | 9.0(255)             | 90(6.3)      | 13-1/2"(343)   | 1.0   | 7.1        | 3.24 | 1/2"     | 89.7           | 1.0              | 1/4"      |
| QB-124   | 4"(100x16)           | 3/8"-24      | 11000      | 6.0(170)             | 90(6.3)      | 9"(230)        | 0.78  | 3.8        | 1.73 | 3/8"     | 85.7           | 3.0              | 1/4"      |
| QB-125   | 5"(125x22)           | 5/8"-11      | 11000      | 6.0(170)             | 90(6.3)      | 9"(230)        | 0.78  | 3.9        | 1.78 | 3/8"     | 87.0           | 5.9              | 1/4"      |
| QB-134X  | 4"(100x16)           | M10xP1.5     | 11000      | 6.0(170)             | 90(6.3)      | 9"(230)        | 0.78  | 4.0        | 1.8  | 3/8"     | 89.0           | 1.2              | 1/4"      |
| QB-135X  | 5"(125x22)           | M14xP2.0     | 11000      | 6.0(170)             | 90(6.3)      | 9"(230)        | 0.78  | 4.0        | 1.8  | 3/8"     | 89.0           | 1.2              | 1/4"      |
| QB-154X  | 4"(100x16)           | 3/8"-24      | 11000      | 6.0(170)             | 90(6.3)      | 9"(230)        | 0.78  | 3.7        | 1.7  | 3/8"     | 89.0           | 1.2              | 1/4"      |
| QB-155X  | 5"(125x22)           | 5/8"-11      | 11000      | 6.0(170)             | 90(6.3)      | 9"(230)        | 0.78  | 3.8        | 1.7  | 3/8"     | 89.0           | 1.2              | 1/4"      |
| QB-144X  | 4"(100x16)           | M10xP1.5     | 11000      | 6.0(170)             | 90(6.3)      | 8-7/8"(225)    | 0.78  | 3.9        | 1.8  | 3/8"     | 89.0           | 1.2              | 1/4"      |
| QB-145X  | 5"(125x22)           | M14xP2.0     | 11000      | 6.0(170)             | 90(6.3)      | 8-7/8"(225)    | 0.78  | 4.0        | 1.8  | 3/8"     | 89.0           | 1.2              | 1/4"      |
| QB-164X  | 4"(100x16)           | 3/8"-24      | 11000      | 6.0(170)             | 90(6.3)      | 8-7/8"(225)    | 0.78  | 3.9        | 1.8  | 3/8"     | 89.0           | 1.2              | 1/4"      |
| QB-165X  | 5"(125x22)           | 5/8"-11      | 11000      | 6.0(170)             | 90(6.3)      | 8-7/8"(225)    | 0.78  | 4.0        | 1.8  | 3/8"     | 89.0           | 1.2              | 1/4"      |
| QB-177   | 7"(178x22)           | 5/8"-11      | 7600       | 6.0(170)             | 90(6.3)      | 11-13/16"(300) | 2.0   | 7.2        | 3.3  | 3/8"     | 92.0           | 2.7              | 1/4"      |
| QB-179   | 9"(230x22)           | 5/8"-11      | 6000       | 7.0(198)             | 90(6.3)      | 11"(279)       | 3.8   | 13.2       | 6.0  | 3/4"     | 86.0           | 2.1              | 1/2"      |

AIR ANGLE GRINDER

# AIR ANGLE GRINDER

• Note : The grinding wheel is not supplied along with the tool

## QB-185 AIR VERTICAL GRINDER Lever type throttle



4 pieces in one carton



## QB-187 AIR VERTICAL GRINDER Lever type throttle



4 pieces in one carton



## QB-192/QB-192L Roll type throttle / Lever type throttle



10 pieces in one carton



QA-192

QA-192L

## QB-193/QB-193L Roll type throttle / Lever type throttle



10 pieces in one carton



QA-193

QA-193L

## QB-194/QB-194L Roll type throttle / Lever type throttle



10 pieces in one carton

6 pieces in one carton



QA-194

QA-194L

## QB-194CN Roll type throttle



9 pieces in one carton



## QB-195-85 QB-195-120 Roll type throttle



10 pieces in one carton



## QB-195L-85 QB-195L-120 Lever type throttle



6 pieces in one carton



## QB-195CN Roll type throttle



9 pieces in one carton



## QB-197Q Lever type throttle



6 pieces in one carton



## QB-199 S/M Lever type throttle



4 pieces in one carton



## QB-623 2" AIR ANGLE GRINDER Lever type throttle



10 pieces in one carton



• Note : The grinding wheel is not supplied along with the tool

## QB-2925

### AIR STRAIGHT GRINDER

Roll type throttle



12 pieces in one carton



Used with straight grinding wheel

## QB-2925L

### AIR STRAIGHT GRINDER

Lever type throttle



12 pieces in one carton



Used with straight grinding wheel

## QB-7114 S/M QB-7115 S/M QB-7145 S/M

### 100° 1.3HP AIR ANGLE GRINDER

Lever type throttle



6 pieces in one carton



## QB-7215M QB-7245M

### 100° 1.3HP AIR ANGLE GRINDER

Lever type throttle



6 pieces in one carton



## QB-7315 S/M

### 2.3HP AIR ANGLE GRINDER

Lever type throttle



6 pieces in one carton



| Item No.     | Pad Dia / Arbor Size | Spindle Size       | Free Speed | Avg. Air Consumption | Air Pressure | Overall Length | Motor | Net Weight |      | Air Hose | Sound Pressure | Vibration Level | Air Inlet |
|--------------|----------------------|--------------------|------------|----------------------|--------------|----------------|-------|------------|------|----------|----------------|-----------------|-----------|
|              | inch(mm)             |                    |            |                      |              |                |       | HP         | LBS  |          |                |                 |           |
|              |                      |                    |            |                      |              |                |       |            |      |          |                |                 |           |
| QB-185       | 5"(125x22)           | 5/8"-11            | 12000      | 6.0(170)             | 90(6.3)      | 9-9/64"(232)   | 1.4   | 6.2        | 2.8  | 1/2"     | 86.0           | 2.1             | 1/4"      |
| QB-187       | 7"(178x22)           | 5/8"-11            | 7000       | 6.0(170)             | 90(6.3)      | 9-23/32"(247)  | 2.0   | 8.8        | 4.0  | 1/2"     | 86.0           | 2.1             | 1/4"      |
| QB-192       | 2"(50)               | 1/4"-28            | 15000      | 5.3(150)             | 90(6.3)      | 8-7/8"(226)    | 0.36  | 1.3        | 0.6  | 3/8"     | 81.0           | 2               | 3/8"      |
| QB-192L      | 2"(50)               | 1/4"-28            | 15000      | 5.3(150)             | 90(6.3)      | 7-1/2"(190)    | 0.36  | 1.6        | 0.73 | 3/8"     | 81.0           | 2               | 3/8"      |
| QB-193       | 3"(75)               | M8                 | 13500      | 5.8(164)             | 90(6.3)      | 7-1/8"(180)    | 0.44  | 2.4        | 1.1  | 3/8"     | 85.0           | 2.5             | 3/8"      |
| QB-193L      | 3"(75)               | M8                 | 13500      | 5.8(164)             | 90(6.3)      | 7-3/4"(197)    | 0.44  | 2.4        | 1.1  | 3/8"     | 85.0           | 2.5             | 3/8"      |
| QB-194       | 4"(100x16)           | M8x1.25            | 12000      | 4.9(138)             | 90(6.3)      | 8-15/32"(215)  | 0.9   | 4.2        | 1.9  | 3/8"     | 91.0           | 2.6             | 3/8"      |
| QB-194L      | 4"(100x16)           | M8x1.25            | 12000      | 4.9(138)             | 90(6.3)      | 10-23/32"(272) | 0.9   | 4.6        | 2.1  | 3/8"     | 89.0           | 2.5             | 3/8"      |
| QB-194CN     | 4"(100x16)           | M8x1.25            | 13500      | 4.8(136)             | 90(6.3)      | 8-15/64"(210)  | 0.8   | 4.2        | 1.9  | 3/8"     | 92.0           | 2.8             | 3/8"      |
| QB-195-85    | 5"(125x22)           | 1/2"-13            | 8500       | 4.9(138)             | 90(6.3)      | 8-15/16"(227)  | 1.4   | 5.3        | 2.4  | 3/8"     | 91             | 2.1             | 3/8"      |
| QB-195-120   | 5"(125x22)           | 1/2"-13            | 12000      | 5.1(144)             | 90(6.3)      | 8-15/16"(227)  | 1.4   | 5.3        | 2.4  | 3/8"     | 91             | 2.1             | 3/8"      |
| QB-195L-85   | 5"(125x22)           | 1/2"-13            | 8500       | 4.9(138)             | 90(6.3)      | 10-13/16"(275) | 1.4   | 5.5        | 2.5  | 3/8"     | 91             | 2.1             | 3/8"      |
| QB-195L-120  | 5"(125x22)           | 1/2"-13            | 12000      | 5.1(144)             | 90(6.3)      | 10-13/16"(275) | 1.4   | 5.5        | 2.5  | 3/8"     | 91             | 2.1             | 3/8"      |
| QB-195CN     | 5"(125x22)           | M8x1.25            | 12000      | 4.9(138)             | 90(6.3)      | 8-15/32"(215)  | 1.0   | 4.4        | 2.0  | 3/8"     | 91             | 2.6             | 3/8"      |
| QB-197Q      | 7"(178x22)           | 5/8"-11            | 7000       | 6.0(170)             | 90(6.3)      | 13-15/16"(353) | 2.2   | 6.8        | 3.1  | 3/8"     | 77.0           | 2.4             | 3/8"      |
| QB-199(S/M)  | 9"(230x22)           | 5/8" / M14xP2.0    | 5900       | 6.8(178)             | 90(6.3)      | 14"(360)       | 2.5   | 9.9        | 4.5  | 3/8"     | 98.0           | 3.75            | 3/8"      |
| QB-623       | 2"(50x10)            | M14xP2.0           | 19000      | 6.8(178)             | 90(6.3)      | 14"(360)       | 2.5   | 9.9        | 4.5  | 3/8"     | 98.0           | 3.75            | 3/8"      |
| QB-2925      | (65x13x9.5)          | 3/8"-16            | 16000      | 5.0(141)             | 90(6.3)      | 10-11/16"(270) | 0.9   | 2.9        | 1.33 | 3/8"     | 90             | 2.8             | 3/8"      |
| QB-2925L     | (65x13x9.5)          | 3/8"-16            | 16000      | 5.0(141)             | 90(6.3)      | 12-25/32"(324) | 0.9   | 3.0        | 1.39 | 3/8"     | 90             | 2.8             | 3/8"      |
| QB-7114(S/M) | 4"(100)              | 3/8"-24 / M10xP1.5 | 11000      | 4.2(119)             | 90(6.3)      | 9-1/8"(232)    | 1.30  | 4.0        | 1.81 | 3/8"     | 90.0           | 1.2             | 1/4"      |
| QB-7115(S/M) | 5"(125)              | 5/8"-11 / M14xP2.0 | 11000      | 4.2(119)             | 90(6.3)      | 9-1/8"(232)    | 1.30  | 4.0        | 1.81 | 3/8"     | 90.0           | 1.2             | 1/4"      |
| QB-7145(S/M) | 4-1/2"(114)          | 5/8"-11 / M14xP2.0 | 11000      | 4.2(119)             | 90(6.3)      | 9-1/8"(232)    | 1.30  | 4.0        | 1.81 | 3/8"     | 90.0           | 1.2             | 1/4"      |
| QB-7215M     | 5"(125)              | M14xP2.0           | 11000      | 4.2(119)             | 90(6.3)      | 9-1/8"(232)    | 1.3   | 4.0        | 1.8  | 3/8"     | 90.0           | 1.2             | 1/4"      |
| QB-7245M     | 4-1/2"(115)          | M14xP2.0           | 11000      | 4.2(119)             | 90(6.3)      | 9-1/8"(232)    | 1.3   | 4.0        | 1.8  | 3/8"     | 90.0           | 1.2             | 1/4"      |
| QB-7315(S/M) | 5"(127)              | 5/8"-11 / M14xP2.0 | 10000      | 6.9(195)             | 90(6.3)      | 9-1/4"(234)    | 2.3   | 4.0        | 1.8  | 1/2"     | 88             | 3.8             | 1/4"      |

AIR ANGLE GRINDER



# AIR BELT SANDER

## QB-311 AIR BELT SANDER



## QB-312 AIR BELT SANDER



## QB-313 AIR BELT SANDER



## QB-321 AIR BELT SANDER



## QB-322 QB-322C AIR BELT SANDER



## QB-322RC AIR BELT SANDER - ANGLE FLEXIBLE



## QB-324 AIR BELT SANDER



## QB-325N [SET] AIR BELT SANDER



| Item No.     | Belt Size<br>Pad Dia    | Free Speed | Avg. Air<br>Consumption | Air<br>Pressure | Overall<br>Length | Net Weight |      | Air<br>Hose | Sound<br>Pressure | Vibration<br>Level | Air Inlet |
|--------------|-------------------------|------------|-------------------------|-----------------|-------------------|------------|------|-------------|-------------------|--------------------|-----------|
|              | inch(mm)                | R.P.M      | CFM (L/min)             | PSI (bar)       | Inch (mm)         | LBS        | kg   | Inch        | dBA               | m/s <sup>2</sup>   | Inch      |
| QB-311       | 3/8"x13"(10x330)        | 16000      | 8.0(226)                | 90(6.3)         | 11-1/2"(290)      | 1.76       | 0.80 | 3/8"        | 89.7              | 0.5                | 1/4"      |
| QB-312       | 3/4"x20-1/2"(20x520)    | 16000      | 9.0(254)                | 90(6.3)         | 14"(360)          | 2.65       | 1.20 | 3/8"        | 91.8              | 0.4                | 1/4"      |
| QB-313       | 1-3/16"x21-1/4"(30x540) | 13000      | 10.0(283)               | 90(6.3)         | 15-3/8"(390)      | 5.28       | 2.40 | 3/8"        | 81.0              | 1.2                | 1/4"      |
| QB-321       | 3/8"x13"(10x330)        | 16000      | 4.0(113)                | 90(6.3)         | 12-5/8"(320)      | 2.1        | 0.95 | 3/8"        | 88.0              | 1.0                | 1/4"      |
| QB-322       | 3/4"x20-1/2"(20x520)    | 16000      | 4.0(113)                | 90(6.3)         | 17"(430)          | 3.1        | 1.40 | 3/8"        | 88.0              | 1.3                | 1/4"      |
| QB-322C      | 3/4"x20-1/2"(20x520)    | 16000      | 4.0(113)                | 90(6.3)         | 17"(430)          | 3.1        | 1.40 | 3/8"        | 88.0              | 1.3                | 1/4"      |
| QB-322RC     | 3/4"x20-1/2"(20x520)    | 16000      | 4.0(113)                | 90(6.3)         | 17"(430)          | 3.1        | 1.40 | 3/8"        | 88.0              | 1.3                | 1/4"      |
| QB-324       | 1/2"x24"(12.7x610)      | 16000      | 4.0(113)                | 90(6.3)         | 18"(455)          | 2.4        | 0.95 | 3/8"        | 88.0              | 1.1                | 1/4"      |
| QB-325N(P04) | 3/8"x13"(10x330)        | 16000      | 4.0(113)                | 90(6.3)         | 12-5/8"(320)      | 2.1        | 0.95 | 3/8"        | 90                | 1.1                | 1/4"      |
| QB-325N(P52) | 1/4"x13"(6x330)         | 16000      | 4.0(113)                | 90(6.3)         | 12-5/8"(320)      | 2.1        | 0.95 | 3/8"        | 90                | 1.1                | 1/4"      |
| QB-325N(P53) | 3/4"x13"(20x330)        | 16000      | 4.0(113)                | 90(6.3)         | 12-5/8"(320)      | 2.1        | 0.95 | 3/8"        | 90                | 1.1                | 1/4"      |
| QB-325N(P54) | 3/4"x20-1/2"(20x520)    | 16000      | 4.0(113)                | 90(6.3)         | 12-5/8"(320)      | 2.1        | 0.95 | 3/8"        | 90                | 1.1                | 1/4"      |

# AIR SANDER

## Non-Vacuum SERIES



### QB-42

**AIR RANDOM ORBITAL SANDER**  
Non-Vacuum



8 pieces in one carton

- 5" QB-42502 5mm orbit
- 6" QB-42602 5mm orbit



### QB-46

**AIR RANDOM ORBITAL SANDER**  
Non-Vacuum



10 pieces in one carton

- 5" QB-46502 5mm orbit
- 5" QB-46512 2.5mm orbit
- 6" QB-46602 5mm orbit
- 6" QB-46612 2.5mm orbit



### QB-49602

**DUAL ACTION SANDER**  
Non-Vacuum 9.5mm orbit



10 pieces in one carton



### QB-52

**AIR RANDOM ORBITAL SANDER**  
Non-Vacuum



8 pieces in one carton

- 5" QB-52502 5mm orbit
- 6" QB-52602 5mm orbit



### QB-55

**AIR RANDOM ORBITAL SANDER**  
Non-Vacuum



12 pieces in one carton

- 3" QB-55312 2.5mm orbit
- 5" QB-55502 5mm orbit
- 6" QB-55602 5mm orbit



QB-55312

### QB-58502 QB-58602

**AIR 2-HAND RANDOM ORBITAL SANDER**  
Non-Vacuum 5mm orbit



6 pieces in one carton



## Non-Vacuum Sander Accessories

Velcro Or Vinyl Sanding Pad Both Available

Backing Face : velcro



Blister+Card

| ITEM NO. | SIZE | Max R.P.M |
|----------|------|-----------|
| QB-9302  | 2"   | 15000     |
| QB-9303  | 3"   | 15000     |
| QB-9305  | 5"   | 12000     |
| QB-9306  | 6"   | 12000     |

Backing Face : vinyl



Blister+Card

| ITEM NO. | SIZE | Max R.P.M |
|----------|------|-----------|
| QB-9345  | 5"   | 12000     |
| QB-9307  | 6"   | 12000     |

| Item No. | Pad Dia  | Free Speed | Avg. Air Consumption | Air Pressure | Overall Length | Motor | Net Weight |      | Air Hose | Sound Pressure | Vibration Level  | Orbit | Air Inlet |
|----------|----------|------------|----------------------|--------------|----------------|-------|------------|------|----------|----------------|------------------|-------|-----------|
|          | inch(mm) | R.P.M      | CFM (L/min)          | PSI (bar)    | Inch (mm)      | HP    | LBS        | kg   | Inch     | dBA            | m/s <sup>2</sup> | mm    | Inch      |
| QB-42502 | 5"(127)  | 10000      | 3.85(109)            | 90(6.3)      | 6"(153)        | 0.24  | 1.7        | 0.81 | 3/8"     | 75.7           | 1.4              | 5     | 1/4"      |
| QB-42602 | 6"(152)  | 10000      | 3.85(109)            | 90(6.3)      | 6-1/2"(166)    | 0.24  | 1.8        | 0.85 | 3/8"     | 74.4           | 1.4              | 5     | 1/4"      |
| QB-46502 | 5"(127)  | 10000      | 3.85(109)            | 90(6.3)      | 6"(153)        | 0.24  | 1.74       | 0.79 | 3/8"     | 80.1           | 2.2              | 5     | 1/4"      |
| QB-46512 | 5"(127)  | 10000      | 3.85(109)            | 90(6.3)      | 6"(153)        | 0.24  | 1.74       | 0.79 | 3/8"     | 80.1           | 2.2              | 2.5   | 1/4"      |
| QB-46602 | 6"(152)  | 10000      | 3.85(109)            | 90(6.3)      | 6-1/2"(166)    | 0.24  | 1.74       | 0.79 | 3/8"     | 80.1           | 2.2              | 5     | 1/4"      |
| QB-46612 | 6"(152)  | 10000      | 3.85(109)            | 90(6.3)      | 6-1/2"(166)    | 0.24  | 1.74       | 0.79 | 3/8"     | 80.1           | 2.2              | 2.5   | 1/4"      |
| QB-49602 | 6"(152)  | 10000      | 3.60(102)            | 90(6.3)      | 8-21/32"(220)  | 0.75  | 2.0        | 0.9  | 3/8"     | 92.5           | 3.3              | 9.5   | 1/4"      |
| QB-52502 | 5"(127)  | 10000      | 6.0(170)             | 90(6.3)      | 6"(153)        | 0.24  | 2.2        | 1.00 | 3/8"     | 87.6           | 1.2              | 5     | 1/4"      |
| QB-52602 | 6"(152)  | 10000      | 6.0(170)             | 90(6.3)      | 6-1/2"(166)    | 0.24  | 2.65       | 1.20 | 3/8"     | 87.6           | 1.7              | 5     | 1/4"      |
| QB-55312 | 3"(76)   | 11000      | 3.0(85)              | 90(6.3)      | 5-1/8"(157)    | 0.24  | 1.45       | 0.66 | 3/8"     | 81.6           | 1.5              | 2.5   | 1/4"      |
| QB-55502 | 5"(127)  | 10000      | 3.0(85)              | 90(6.3)      | 6-11/16"(170)  | 0.24  | 1.5        | 0.68 | 3/8"     | 81.6           | 1.5              | 5     | 1/4"      |
| QB-55602 | 6"(152)  | 10000      | 3.0(85)              | 90(6.3)      | 6-11/16"(170)  | 0.24  | 1.5        | 0.68 | 3/8"     | 81.6           | 1.5              | 5     | 1/4"      |
| QB-58502 | 5"(127)  | 10000      | 3.10(88)             | 90(6.3)      | 9-7/16"(240)   | 0.4   | 2.6        | 1.2  | 3/8"     | 80.0           | 1.3              | 5     | 1/4"      |
| QB-58602 | 6"(152)  | 10000      | 3.10(88)             | 90(6.3)      | 9-7/16"(240)   | 0.4   | 2.6        | 1.2  | 3/8"     | 80.0           | 1.3              | 5     | 1/4"      |

# AIR SANDER

## Self-Generated Vacuum

### SERIES



## QB-20203

**AIR RANDOM ORBITAL SANDER**  
Self-Vacuum



20 pieces in one carton

- Note : 2" Sanding pad & 3" Sanding is supplied along with the tool



## QB-43

**AIR RANDOM ORBITAL SANDER**  
Self-Generated Vacuum



6 pieces in one carton

- 5" QB-43802 5mm orbit
- 6" QB-43902 5mm orbit



## QB-47

**AIR RANDOM ORBITAL SANDER**  
Self-Generated Vacuum



6 pieces in one carton

- 6" QB-47602 5mm orbit
- 6" QB-47612 2.5mm orbit



## QB-53

**AIR RANDOM ORBITAL SANDER**  
Self-Generated Vacuum



8 pieces in one carton

- 5" QB-53802 5mm orbit
- 6" QB-53902 5mm orbit



## QB-56

**AIR RANDOM ORBITAL SANDER**  
Self-Generated Vacuum



12 pieces in one carton

- 5" QB-56502 5mm orbit
- 6" QB-56602 5mm orbit



## QB-59602

**AIR 2-HAND RANDOM ORBITAL SANDER**  
Self-Generated Vacuum



6 pieces in one carton



Air Regulator

## Central-Vacuum

### SERIES



## QB-41

**AIR RANDOM ORBITAL SANDER**  
Central-Vacuum



8 pieces in one carton

- 6" QB-41902 5mm orbit



## QB-45

**AIR RANDOM ORBITAL SANDER**  
Central-Vacuum



10 pieces in one carton

- 6" QB-45602 5mm orbit
- 6" QB-45612 2.5mm orbit



## QB-54

**AIR RANDOM ORBITAL SANDER**  
Central-Vacuum



12 pieces in one carton

- 5" QB-54502
- 6" QB-54602 (six hole pad)
- 6" QB-54702 (fifteen hole pad)



## QB-51602 QB-51612

**AIR RANDOM ORBITAL SANDER**  
Central-Vacuum



12 pieces in one carton



## QB-57602

**AIR 2-HAND RANDOM ORBITAL SANDER**  
Central-Vacuum 5mm orbit



6 pieces in one carton



Air Regulator



Air Gear Driven Sander



## QB-57642

**AIR 2-HAND  
RANDOM ORBITAL SANDER**  
Central-Vacuum



6 pieces in one carton

## QB-59642

**AIR 2-HAND  
RANDOM ORBITAL SANDER**  
Self-Generated Vacuum



6 pieces in one carton

## QB-58542 QB-58642

**AIR 2-HAND RANDOM ORBITAL SANDER**  
Non-Vacuum 5mm orbit



6 pieces in one carton



QB-57642P39



QB-59642P39



5" QB-58542P39  
6" QB-58642P39

Equipped with QB-57642P39  
6-hole Vacuum Pad

Equipped with QB-59642P39  
6-hole Vacuum Pad

Equipped with QB-58642P39  
Non-Vacuum Pad

| Item No. | Pad Dia  | Free Speed | Avg. Air Consumption | Air Pressure | Overall Length | Motor | Net Weight |      | Air Hose | Sound Pressure | Vibration Level  | Orbit | Air Inlet |
|----------|----------|------------|----------------------|--------------|----------------|-------|------------|------|----------|----------------|------------------|-------|-----------|
|          | inch(mm) | R.P.M      | CFM (L/min)          | PSI (bar)    | Inch (mm)      | HP    | LBS        | kg   | Inch     | dBA            | m/s <sup>2</sup> | mm    | Inch      |
| QB-20203 | 2" + 3"  | 14000      | 3.0(85)              | 90(6.3)      | 5-1/8"(130)    | ---   | 1.1        | 0.5  | 3/8"     | 81.6           | 1.5              | 3.0   | 1/4"      |
| QB-43802 | 5"(127)  | 10000      | 3.85(109)            | 90(6.3)      | 8"(206)        | 0.24  | 3.28       | 1.49 | 3/8"     | 83.9           | 1.3              | 5     | 1/4"      |
| QB-43902 | 6"(152)  | 10000      | 3.85(109)            | 90(6.3)      | 8-3/4"(221)    | 0.24  | 3.39       | 1.54 | 3/8"     | 83.0           | 1.4              | 5     | 1/4"      |
| QB-47602 | 6"(152)  | 10000      | 3.85(109)            | 90(6.3)      | 7-1/2"(193)    | 0.24  | 2.49       | 1.13 | 3/8"     | 84.7           | 2.2              | 5     | 1/4"      |
| QB-47612 | 6"(152)  | 10000      | 3.85(109)            | 90(6.3)      | 7-1/2"(193)    | 0.24  | 2.49       | 1.13 | 3/8"     | 84.7           | 2.2              | 2.5   | 1/4"      |
| QB-53802 | 5"(127)  | 10000      | 6(170)               | 90(6.3)      | 6"(153)        | 0.24  | 2.2        | 1.00 | 3/8"     | 86.2           | 1.1              | 5     | 1/4"      |
| QB-53902 | 6"(152)  | 10000      | 6(170)               | 90(6.3)      | 6-1/2"(166)    | 0.24  | 2.65       | 1.20 | 3/8"     | 80.1           | 1.2              | 5     | 1/4"      |
| QB-56502 | 5"(127)  | 10000      | 3.0(85)              | 90(6.3)      | 8-1/4"(210)    | 0.24  | 1.7        | 0.78 | 3/8"     | 81.6           | 1.5              | 5     | 1/4"      |
| QB-56602 | 6"(152)  | 10000      | 3.0(85)              | 90(6.3)      | 8-1/4"(210)    | 0.24  | 1.7        | 0.78 | 3/8"     | 81.6           | 1.5              | 5     | 1/4"      |
| QB-59602 | 6"(152)  | 10000      | 3.10(88)             | 90(6.3)      | 9-7/16"(240)   | 0.4   | 2.6        | 1.2  | 3/8"     | 80.0           | 1.3              | 5     | 1/4"      |
| QB-41902 | 6"(152)  | 10000      | 3.85(109)            | 90(6.3)      | 8"(206)        | 0.24  | 2.0        | 0.91 | 3/8"     | 81.5           | 1.2              | 5     | 1/4"      |
| QB-45602 | 6"(152)  | 10000      | 3.85(109)            | 90(6.3)      | 7-1/2"(193)    | 0.24  | 1.85       | 0.84 | 3/8"     | 81.6           | 2.2              | 5     | 1/4"      |
| QB-45612 | 6"(152)  | 10000      | 3.85(109)            | 90(6.3)      | 7-1/2"(193)    | 0.24  | 1.85       | 0.84 | 3/8"     | 81.6           | 2.2              | 2.5   | 1/4"      |
| QB-54502 | 5"(127)  | 10000      | 3.0(85)              | 90(6.3)      | 7-3/4"(197)    | 0.24  | 1.65       | 0.78 | 3/8"     | 81.6           | 1.5              | 5     | 1/4"      |
| QB-54602 | 6"(152)  | 10000      | 3.0(85)              | 90(6.3)      | 8-1/4"(210)    | 0.24  | 1.7        | 0.78 | 3/8"     | 81.6           | 1.5              | 5     | 1/4"      |
| QB-54702 | 6"(152)  | 10000      | 3.0(85)              | 90(6.3)      | 8-1/4"(210)    | 0.24  | 1.7        | 0.78 | 3/8"     | 81.6           | 1.5              | 5     | 1/4"      |
| QB-51602 | 6"(152)  | 12000      | 3.0(85)              | 90(6.3)      | 8-7/8"(225)    | 0.24  | 2          | 0.9  | 3/8"     | 81.6           | 1.5              | 5     | 1/4"      |
| QB-51612 | 6"(152)  | 12000      | 3.0(85)              | 90(6.3)      | 8-7/8"(225)    | 0.24  | 2          | 0.9  | 3/8"     | 81.6           | 1.5              | 5     | 1/4"      |
| QB-57602 | 6"(152)  | 10000      | 3.10(88)             | 90(6.3)      | 9-7/16"(240)   | 0.40  | 2.6        | 1.2  | 3/8"     | 80.0           | 1.3              | 5     | 1/4"      |
| QB-57642 | 6"(152)  | 900        | 3.10(88)             | 90(6.3)      | 9-7/16"(240)   | 0.4   | 3.5        | 1.6  | 3/8"     | 82.0           | <2.5             | 5     | 1/4"      |
| QB-59642 | 6"(152)  | 900        | 3.10(88)             | 90(6.3)      | 9-7/16"(240)   | 0.4   | 3.5        | 1.6  | 3/8"     | 82.0           | <2.5             | 5     | 1/4"      |
| QB-58542 | 5"(127)  | 900        | 3.10(88)             | 90(6.3)      | 9-7/16"(240)   | 0.4   | 3.3        | 1.5  | 3/8"     | 82.0           | <2.5             | 5     | 1/4"      |
| QB-58642 | 6"(152)  | 900        | 3.10(88)             | 90(6.3)      | 9-7/16"(240)   | 0.4   | 3.5        | 1.6  | 3/8"     | 82.0           | <2.5             | 5     | 1/4"      |

AIR SANDER

# AIR SQUARE SANDER

AIR SQUARE SANDER

## QB-48012

**AIR JITTERBUG SANDER**  
Non-Vacuum 2.5mm orbit

12 pieces in one carton

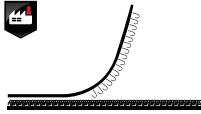

Use with  
**VELCRO TYPE**  
Sanding Paper



NON-VACUUM



## QB-48111

**AIR JITTERBUG SANDER**  
Non-Vacuum 2.5mm orbit

12 pieces in one carton



Sanding paper  
mounted by **CLIP**



NON-VACUUM



## QB-48112

**AIR JITTERBUG SANDER**  
Non-Vacuum 2.5mm orbit

12 pieces in one carton

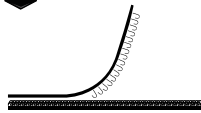

Use with  
**VELCRO TYPE**  
Sanding Paper



NON-VACUUM



## QB-48212

**AIR JITTERBUG SANDER**  
Non-Vacuum 2.5mm orbit

12 pieces in one carton

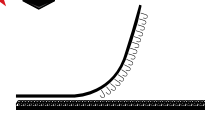

Use with  
**VELCRO TYPE**  
Sanding Paper



NON-VACUUM



## QB-48211

**AIR JITTERBUG SANDER**  
Non-Vacuum 2.5mm orbit

5 pieces in one carton



Sanding paper  
mounted by **CLIP**



NON-VACUUM

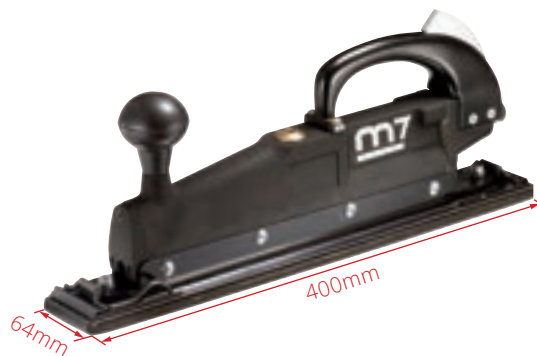

| Item No. | Pad Dia                | Free Speed | Avg. Air Consumption | Air Pressure | Overall Length | Motor | Net Weight |      | Air Hose | Sound Pressure | Vibration Level  | Orbit | Air Inlet |
|----------|------------------------|------------|----------------------|--------------|----------------|-------|------------|------|----------|----------------|------------------|-------|-----------|
|          | inch(mm)               | R.P.M      | CFM (L/min)          | PSI (bar)    | Inch (mm)      | HP    | LBS        | kg   | Inch     | dB(A)          | m/s <sup>2</sup> | mm    | Inch      |
| QB-48012 | 3"x4"(75x100)          | 10000      | 5.0(141)             | 90(6.3)      | 5-3/8"(137)    | 0.24  | 1.83       | 0.83 | 3/8"     | 83.0           | 1.5              | 2.5   | 1/4"      |
| QB-48111 | 4"x4-3/8"(100x110)     | 11000      | 7.0(198)             | 90(6.3)      | 5-1/5"(130)    | 0.28  | 2.0        | 0.91 | 3/8"     | 83.0           | 1.5              | 2.5   | 1/4"      |
| QB-48112 | 4"x4-3/8"(100x110)     | 10000      | 5.0(141)             | 90(6.3)      | 5-3/8"(136)    | 0.24  | 1.7        | 0.78 | 3/8"     | 83.0           | 1.5              | 2.5   | 1/4"      |
| QB-48211 | 2-1/2"x15-3/4"(64x100) | 2100       | 5.0(141)             | 90(6.3)      | 17-1/2"(144)   | 0.24  | 6.1        | 2.8  | 3/8"     | 83.0           | 1.5              | 2.5   | 1/4"      |
| QB-48212 | 7"x3-1/2"(93x180)      | 10000      | 5.0(141)             | 90(6.3)      | 7"(180)        | 0.24  | 2.0        | 0.94 | 3/8"     | 83.0           | 1.5              | 2.5   | 1/4"      |

**QP-111**  
**1" AIR ANGLE SANDER**

10 pieces in one carton



**QP-113**  
**AIR PISTOL SANDER**  
2.5mm orbit

10 pieces in one carton



**QP-123**  
**AIR PISTOL POLISHER**

10 pieces in one carton



**QP-123QP**  
**AIR PISTOL POLISHER**

10 pieces in one carton

- Air Pistol Sander, 3" Pad Dia
- QP-113 :Air Pistol Sander, 3" Pad Dia
- QP-123 :Air Pistol Polisher, 3" Pad Dia
- 1/4" Air Adaptor Couplings Male Thread Type
- 3" Sponge (Rough) & 3" Sponge (Medium)



**QP-215**  
**AIR HIGH SPEED SANDER**

10 pieces in one carton



**QP-307 S/M**  
**QP-327 S/M**  
**AIR ANGLE POLISHER**

6 pieces in one carton



**QP-317**  
**AIR ANGLE POLISHER**

10 pieces in one carton



**QP-335**  
**VERTICAL POLISHER**

10 pieces in one carton



| Item No.    | Pad Dia  | Spindle Size    | Free Speed | Avg. Air Consumption | Air Pressure | Overall Length | Motor | Net Weight |      | Air Hose | Sound Pressure | Vibration Level  | Orbit | Air Inlet |
|-------------|----------|-----------------|------------|----------------------|--------------|----------------|-------|------------|------|----------|----------------|------------------|-------|-----------|
|             | inch(mm) |                 | R.P.M      | CFM (L/min)          | PSI (bar)    | Inch (mm)      | HP    | LBS        | kg   | Inch     | dBA            | m/s <sup>2</sup> | mm    | Inch      |
| QP-111      | 1"(26)   | M10xP1.5        | 8000       | 2.7(152)             | 90(6.3)      | 6-3/8"(162)    | 0.3   | 1.2        | 0.55 | 3/8"     | 89.0           | 0.3              | ---   | 1/4"      |
| QP-113      | 3"(76)   | 5/16"-24        | 15000      | 3.5(99)              | 90(6.3)      | 5"(127)        | 0.40  | 1.5        | 0.72 | 3/8"     | 74.0           | 0.3              | 2.5   | 1/4"      |
| QP-123      | 3"(76)   | 5/16"-24        | 2100       | 3.5(99)              | 90(6.3)      | 5-5/16"(135)   | 0.40  | 1.69       | 0.77 | 3/8"     | 74.0           | 0.21             | ---   | 1/4"      |
| QP-215      | 5"(127)  | 7/16"-20        | 16000      | 6.5(184)             | 90(6.3)      | 6-19/64"(160)  | 0.80  | 2.6        | 1.20 | 3/8"     | 60.0           | 1.8              | ---   | 1/4"      |
| QP-307(S/M) | 7"(178)  | 5/8"-11(M14xP2) | 4500       | 6.0(169)             | 90(6.3)      | 16"(406)       | 0.40  | 4.0        | 2.04 | 3/8"     | 84.0           | 2.5              | ---   | 1/4"      |
| QP-317      | 7"(178)  | 5/8"-11         | 2500       | 6.0(169)             | 90(6.3)      | 16"(406)       | 0.40  | 4.0        | 2.04 | 3/8"     | 84.0           | 2.5              | ---   | 1/4"      |
| QP-327(S/M) | 7"(178)  | 5/8"-11(M14xP2) | 2500       | 6.0(169)             | 90(6.3)      | 16"(406)       | 0.40  | 4.0        | 2.04 | 3/8"     | 84.0           | 2.5              | ---   | 1/4"      |
| QP-335      | 5"(127)  | 5/16"-24        | 3000       | 3.65(103)            | 90(6.3)      | 8"(203)        | 0.55  | 1.12       | 0.53 | 3/8"     | 85.0           | <2.5             | ---   | 1/4"      |

**Air chamfering tools**

**QC-512**  
**MINI AIR CHAMFERING TOOLS**

10 pieces in one carton

- Extreme small size and light weight air tool.
- Also have variable chamfering speed function.

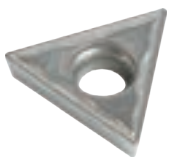

Triangle Indexable Inserts



| Item No. | Chamfering Capacity | Free Speed | Avg. Air Consumption | Air Pressure | Overall Length | Net Weight |     | Air Hose | Sound Pressure |
|----------|---------------------|------------|----------------------|--------------|----------------|------------|-----|----------|----------------|
|          |                     | R.P.M      | CFM (L/min)          | PSI (bar)    | Inch (mm)      | LBS        | kg  | Inch     | dBA            |
| QC-512   | C0.1 - C2.0         | 28000      | 2                    | 90(6.3)      | 4-1/7"(105)    | 1.1        | 0.5 | 3/8"     | 85             |

# AIR CUTTING TOOLS

AIR CUTTING TOOLS

## QC-213

**3" HEAVY DUTY AIR CUT-OFF TOOL**  
Available Dimension of inner hold : Ø 3/8"



10 pieces in one carton

Note : Wheel is supplied with the tool



3" Wheel

## QC-234

**4" HEAVY DUTY AIR CUT-OFF TOOL**  
Available Dimension of inner hold : Ø 10mm



10 pieces in one carton



4" Wheel

## QC-253

**3" AIR CUT-OFF TOOL**



10 pieces in one carton

Note : Wheel is supplied with the tool



## QC-213T

**3" HEAVY DUTY AIR CUT-OFF TOOL**  
Available Dimension of inner hold : Ø 3/8"



10 pieces in one carton

Note : Wheel is supplied with the tool



3" Wheel *Stylized grip*

## QC-234T

**4" AIR CORNER CUT-OFF TOOL**  
Available Dimension of inner hold : Ø 10mm Ø 16mm



10 pieces in one carton

Note : Wheel is supplied with the tool



4" Wheel *Stylized grip*

## QC-254

**4" AIR CORNER CUT-OFF TOOL**  
Available Dimension of inner hold : Ø 10mm



10 pieces in one carton

Note : Wheel is supplied with the tool



## QC-264

**4" AIR CORNER CUT-OFF TOOL**  
Available Dimension of inner hold : Ø 10mm Ø 16mm



10 pieces in one carton



4" Wheel *Stylized grip*

## QC-333

**FLEX-HEAD AIR CUT-OFF TOOL**



10 pieces in one carton

Note : Wheel is supplied with the tool



3" Wheel

3 Angle Adjustable

| Item No. | Belt Size Pad Dia | Free Speed | Avg. Air Consumption | Air Pressure | Overall Length | Motor | Net Weight |      | Air Hose | Sound Pressure | Vibration Level  | Air Inlet |
|----------|-------------------|------------|----------------------|--------------|----------------|-------|------------|------|----------|----------------|------------------|-----------|
|          | inch(mm)          | R.P.M      | CFM (L/min)          | PSI (bar)    | Inch (mm)      | HP    | LBS        | kg   | Inch     | dB(A)          | m/s <sup>2</sup> | Inch      |
| QC-213   | 3"(75)            | 20000      | 10.0(283)            | 90(6.3)      | 7-7/8"(200)    | 0.9   | 1.9        | 0.86 | 3/8"     | 80.2           | 10.8             | 1/4"      |
| QC-213T  | 3"(75)            | 22000      | 5.0(141)             | 90(6.3)      | 7-7/8"(200)    | 0.5   | 1.8        | 0.82 | 3/8"     | 85.0           | 3.0              | 1/4"      |
| QC-234   | 4"(100)           | 16000      | 10.0(283)            | 90(6.3)      | 14"(355)       | 0.9   | 3.5        | 1.59 | 3/8"     | 85.0           | 5.0              | 1/4"      |
| QC-234T  | 4"(100)           | 15000      | 5.0(141)             | 90(6.3)      | 13-9/16"(345)  | 0.5   | 3.1        | 1.41 | 3/8"     | 85.0           | 2.2              | 1/4"      |
| QC-253   | 3"(75)            | 24000      | 4.0(113)             | 90(6.3)      | 8"(203)        | 0.6   | 1.7        | 0.8  | 3/8"     | 91.0           | 1.2              | 1/4"      |
| QC-254   | 4"(100)           | 20000      | 5.0(141)             | 90(6.3)      | 8-1/8"(206)    | 0.6   | 2.0        | 0.9  | 3/8"     | 81.0           | 0.8              | 1/4"      |
| QC-264   | 4"(100)           | 15000      | 5.0(141)             | 90(6.3)      | 9-5/32"(232)   | 0.5   | 2.4        | 1.1  | 3/8"     | 85.0           | 2.2              | 1/4"      |
| QC-333   | 3"                | 20000      | 3.6(102)             | 90(6.3)      | 9-1/16"(230)   | ---   | 2.42       | 1.1  | 3/8"     | ---            | ---              | 1/4"      |

### QD-221

#### AIR SAW WITH HOSE

★★★

10 pieces in one carton

- 5pcs 4.0mm file set included
- 1pc 32T saw blade included

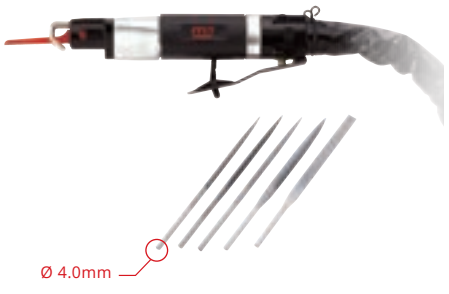

### QD-230

#### AIR MINI SAW WITH HOSE

★★★

10 pieces in one carton

- 4pcs 5.0mm file set included
- 1pc 32T saw blade included

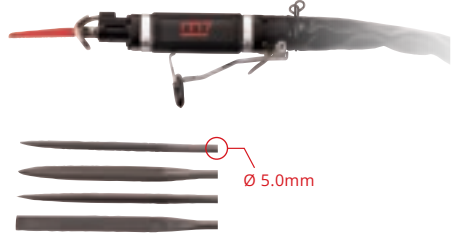

### QD-242

#### AIR FILE WITH HOSE

★★★

10 pieces in one carton

Note: The air mini saw is not supplied along with the tool

- 5pcs 5.0mm file set included



### QD-260

#### AIR MINI SAW / FILE

★★★

20 pieces in one carton

Note: The package contains a flat file and two saw blades

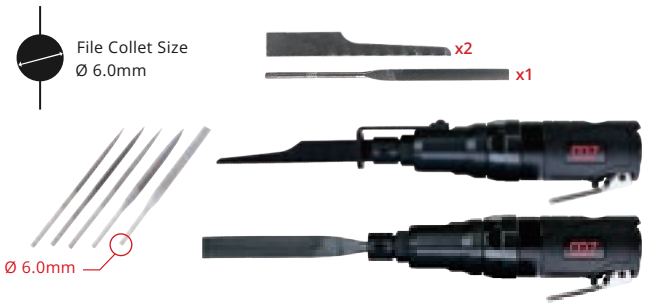

### QD-291N

#### AIR SAW SET

★★★

10 pieces in one carton

#### Contents

- 1pc - Air saw tool
- 6pcs - 24T Saw Blade
- 6pcs - 32T Saw Blade
- 1pc - Allen Key : 4mm, 3mm
- 1/4" 360° plug
- 5 Pieces file set
- 1pc - Mini oiler 1/4"



### QD-321

#### LOW VIBRATION AIR BODY SAW

★★★

15 pieces in one carton



### QD-501

#### GEAR DRIVEN AIR SAW (3 in 1)

★★★

10 pieces in one carton

Note: The File is not supplied along with the tool.

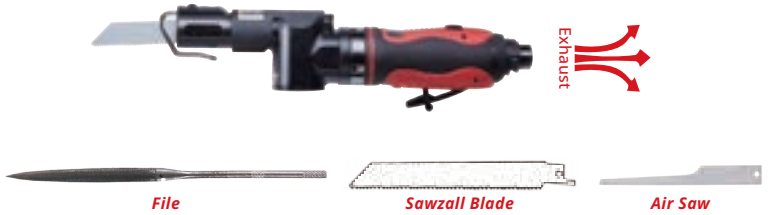

| Item No. | Strokes Length | Strokes Per min | Collet Size | Avg. Air Consumption | Air Pressure | Overall Length | Motor | Net Weight |      | Air Hose | Sound Pressure | Vibration Level | Air Inlet        |
|----------|----------------|-----------------|-------------|----------------------|--------------|----------------|-------|------------|------|----------|----------------|-----------------|------------------|
|          | mm             | S.P.M           |             | CFM (L/min)          | PSI (bar)    | Inch (mm)      |       | HP         | LBS  | kg       | Inch           | dBA             | m/s <sup>2</sup> |
| QD-221   | 10             | 5000            | 4.0         | 4.0(113)             | 90(6.3)      | 9-3/4"(250)    | ---   | 1.76       | 0.8  | 3/8"     | 81.9           | 4.1             | 1/4"             |
| QD-230   | 5              | 7000            | 5.0         | 2.5(70)              | 90(6.3)      | 7"(180)        | ---   | 1.10       | 0.5  | 3/8"     | 78.0           | 2.4             | 1/4"             |
| QD-242   | 5              | 7000            | 5.0         | 5.3(150)             | 90(6.3)      | 17-9/16"(700)  | ---   | 1.28       | 0.58 | 3/8"     | 80.0           | 4.5             | 1/4"             |
| QD-260   | 8              | 7000            | 6.0         | 4.5(127)             | 90(6.3)      | 6-11/16"(170)  | 0.3   | 1          | 0.6  | 3/8"     | 80.0           | 2.4             | 1/4"             |
| QD-291   | 10             | 9000            | 5.0         | 4.0(113)             | 90(6.3)      | 9-1/4"(235)    | ---   | 1.30       | 0.6  | 3/8"     | 83.0           | 2.0             | 1/4"             |
| QD-321   | 14.5           | 11000           | 5.0         | 4.0(113)             | 90(6.3)      | 9-1/4"(230)    | ---   | 1.7        | 0.5  | 3/8"     | 88.0           | 3.4             | 1/4"             |
| QD-501   | 10             | 7000            | 5.0         | 4.5(127)             | 90(6.3)      | 11-5/8"(296)   | 0.5   | 2.6        | 1.2  | 3/8"     | 78.0           | 4.5             | 1/4"             |



# AIR CUTTING TOOLS

## IQG-102

**AIR SHEAR** Straight type

★★★  10 pieces in one carton



## IQG-103

**AIR NIBBLER**

★★★   10 pieces in one carton













## IQG-202

**AIR SHEAR** Pistol type

★★★  10 pieces in one carton



| Item No. | Strokes Per min | Avg. Air Consumption  | Air Pressure  | Overall Length  | Net Weight  |   | Air Hose  | Sound Pressure   | Vibration Level   | Cut Capacity  |   | Air Inlet   |
|----------|-----------------|---|---|---|---|---|---|--|---|---|---|---|
|          | S.P.M           | CFM (L/min)   | PSI (bar)   | Inch (mm)   | LBS   | kg  | Inch  | dBA  | m/s <sup>2</sup>  | mm  | mm  | Inch  |
|          | <b>S.P.M</b>    |  |  |  |  |  |  |  |  |  |  |  |
| QG-102   | 2600            | 6.0(170)  | 90(6.3)   | 10"(254)  | 2.2   | 1.00  | 3/8"  | 85.8   | 2.4   | 1.2   | 1.6   | 1/4"  |
| QG-103   | 2600            | 3.0(85)   | 90(6.3)   | 7-3/5"(193)   | 2.2   | 1.00  | 3/8"  | 88.0   | 2.8   | 1.2   | 1.6   | 1/4"  |
| QG-202   | 2600            | 6.5(184)  | 90(6.3)   | 8-1/4"(210)   | 2.4   | 1.10  | 3/8"  | 89.1   | 2.9   | 1.2   | 1.6   | 1/4"  |

## IQK-111

**AIR KNIFE** 10 pieces in one carton

★★★  



QK-111P51 QK-111P52 QK-111P53 QK-2090



QK-2063 QK-2036 QK-111P08 QK-111P54 QK-111P50



## IQK-111T

**AIR KNIFE** 10 pieces in one carton

★★★  



## IQK-121

**AIR KNIFE** 10 pieces in one carton

★★★  

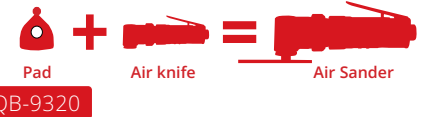

## IQK-131

**AIR OSCILLATING TOOL WITH UNIVERSAL ADAPTER**

★★★    20 pieces in one carton



Patented flange can share pneumatic

Note : Blade is not supplied along with the tool

## IQK-112/QK-112N

**AIR SCRAPER KIT**

Contains Blade

★★★     10 pieces in one carton













QK-112



**QK-112N**

**Blades included :**

- QK-901 : 1" Wide Blade
- QK-902 : 1" Wide 45° Blade
- QK-903 : 1.75" L-Shaped Blade
- QK-904 : 1.77" Wide Blade

| Item No. | Strokes Length  | Strokes Per min | Oscillation   | Avg. Air Consumption  | Air Pressure  | Overall Length  | Net Weight   |   | Air Hose  | Sound Pressure  | Vibration Level   | Air Inlet   |
|----------|---|-----------------|---|---|---|---|--|---|---|---|---|---|
|          | mm  | S.P.M           | per min   | CFM (L/min)   | PSI (bar)   | Inch (mm)   | LBS  | kg  | Inch  | dBA   | m/s <sup>2</sup>  | Inch  |
|          |  | <b>S.P.M</b>    |  |  |  |  |  |  |  |  |  |  |
| QK-111   | ---   | ---             | 20000   | 6.0(170)  | 90(6.3)   | 7-5/64"(180)  | 2.4  | 1.1   | 3/8"  | 75  | 3.9   | 1/4"  |
| QK-111T  | ---   | ---             | 20000   | 5.0(141)  | 90(6.3)   | 8-3/16"(208)  | 2.0  | 0.92  | 3/8"  | 85  | 3.3   | 1/4"  |
| QK-121   | ---   | ---             | 19000   | 4.3(121)  | 90(6.3)   | 6-15/16"(176)   | 1.3  | 0.6   | 3/8"  | 91  | 2.8   | 1/4"  |
| QK-131   | ---   | ---             | 20000   | 1.9(54)   | 90(6.3)   | 7-1/8"(180)   | 1.5  | 0.7   | 3/8"  | 78  | 4.5   | 1/4"  |
| QK-112   | 16  | 4200            | ---   | 3.0(84.9)   | 90(6.3)   | 7-23/32"(196)   | 1.52   | 0.69  | 3/8"  | 93.0  | 9.0   | 1/4"  |

## PN-150 PN-180

### AIR PUNCH & FLANGE TOOL



10 pieces in one carton



## PN-250 PN-280

### AIR PUNCH & FLANGE TOOL



10 pieces in one carton



| Item No. | Punch Diameter | Capacity     | Avg. Air Consumption | Air Pressure | Overall Length | Net Weight |      | Air Hose | Sound Pressure | Vibration Level  | Air Inlet |
|----------|----------------|--------------|----------------------|--------------|----------------|------------|------|----------|----------------|------------------|-----------|
|          | mm             |              | CFM (L/min)          | PSI (bar)    | Inch (mm)      | LBS        | kg   | Inch     | dBA            | m/s <sup>2</sup> | Inch      |
| PN-150   | 5              | 1.6mm(Steel) | 4.0(113)             | 90(6.3)      | 10"(254)       | 2.5        | 1.15 | 3/8"     | 62.0           | 0.1              | 1/4"      |
| PN-180   | 8              | 1.2mm(Steel) | 4.0(113)             | 90(6.3)      | 10"(254)       | 2.5        | 1.15 | 3/8"     | 62.0           | 0.1              | 1/4"      |
| PN-250   | 5              | 1.6mm(Steel) | 4.0(113)             | 90(6.3)      | 7-15/32"(190)  | 2.6        | 1.2  | 3/8"     | 62.0           | 0.1              | 1/4"      |
| PN-280   | 8              | 1.2mm(Steel) | 4.0(113)             | 90(6.3)      | 7-15/32"(190)  | 2.6        | 1.2  | 3/8"     | 62.0           | 0.1              | 1/4"      |

## Air drill

## PC-2010

### ADJUSTABLE TORQUE AIR TAPPING TOOL



6 pieces in one carton



## PC-901

### ADJUSTABLE TORQUE AIR TAPPING ADAPTER

HEX : 8mm  
For : Air drill, electricity drill, cordless drill, drill machine

20 pieces in one carton



|         | CAPACITY |        |          |
|---------|----------|--------|----------|
|         | steel    | copper | aluminum |
| PC-2010 | M3-M8    | M3-M12 | M3-M12   |
| PC-901  | M3-M6    | M3-M8  | M3-M8    |

| Item No. | Capacity |        |          | Free Speed | Stroke Length | Avg. Air Consumption | Air Pressure | Net Weight |      | Air Hose | Sound Pressure | Vibration Level  | Air Inlet |
|----------|----------|--------|----------|------------|---------------|----------------------|--------------|------------|------|----------|----------------|------------------|-----------|
|          | steel    | copper | aluminum | R.P.M      | inch(mm)      | CFM (L/min)          | PSI (bar)    | LBS        | kg   | Inch     | dBA            | m/s <sup>2</sup> | Inch      |
| PC-2010  | M3-M8    | M3-M12 | M3-M12   | 150        | 12"(305)      | 6.5(184)             | 90(6.3)      | 5.4        | 2.45 | 3/8"     | 82             | 1.5              | 1/4"      |

## QE-231

### SPOT DRILL & HOOK



6 pieces in one carton



### FEATURES

- 8 mm drill bit included
- 6.5,8,10 mm drill are available
- Adjustable chuck for easy control
- Hook is easily removed or installed.
- High quality piston improves torque and efficiency
- Common applications are remove the surface of the solder joints and will not damage steel plate.
- Maximum drill depth : 4.5 mm, steel : 3.8 mm stainless

| Item No. | Chuck Size | Free Speed | Motor | Overall Length | Avg. Air Consumption | Air Pressure | Net Weight |      | Air Hose | Sound Pressure | Vibration Level  | Air Inlet |
|----------|------------|------------|-------|----------------|----------------------|--------------|------------|------|----------|----------------|------------------|-----------|
|          | inch(mm)   | R.P.M      | HP    | inch(mm)       | CFM (L/min)          | PSI (bar)    | LBS        | kg   | Inch     | dBA            | m/s <sup>2</sup> | Inch      |
| QE-231   | 5/16"(8)   | 1600       | 0.50  | 9-1/4"(235)    | 6.0(170)             | 90(6.3)      | 4.4        | 2.00 | 3/8"     | 88.2           | 0.1              | 1/4"      |

# AIR DRILL

## 3/8" QE-2130/QE-2133/QE-2137 1/2" QE-2143

**AIR REVERSIBLE DRILL**



20 pieces in one carton QE-2130/QE-2143

10 pieces in one carton QE-2133/QE-2137

- 4 Running speeds identified by different colour rings for multiple applications.



QE-2130



QE-2143

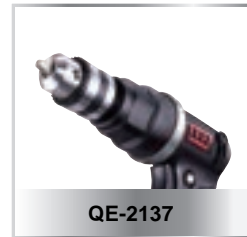

QE-2137



QE-2133

| Item No. | Chuck Size | Free Speed | Motor     | Overall Length | Avg. Air Consumption | Air Pressure | Net Weight |     | Air Hose | Sound Pressure | Vibration Level  | Air Inlet |
|----------|------------|------------|-----------|----------------|----------------------|--------------|------------|-----|----------|----------------|------------------|-----------|
|          | inch(mm)   | R.P.M      | HP        | inch(mm)       | CFM (L/min)          | PSI (bar)    | LBS        | kg  | Inch     | dB(A)          | m/s <sup>2</sup> | Inch      |
|          |            |            | <b>hp</b> |                |                      |              |            |     |          |                |                  |           |
| QE-2130  | 3/8"(10)   | 3500       | 0.5(372w) | 7-1/8"(181)    | 4(113)               | 90(6.3)      | 1.76       | 0.8 | 3/8"     | 92             | 0.2              | 1/4"      |
| QE-2133  | 3/8"(10)   | 2000       | 0.5(372w) | 7-1/8"(181)    | 4(113)               | 90(6.3)      | 1.76       | 0.8 | 3/8"     | 92             | 0.2              | 1/4"      |
| QE-2137  | 3/8"(10)   | 2800       | 0.5(372w) | 7-1/8"(181)    | 4(113)               | 90(6.3)      | 1.76       | 0.8 | 3/8"     | 92             | 0.2              | 1/4"      |
| QE-2143  | 1/2"(13)   | 500        | 0.5(372w) | 9"(228)        | 4(113)               | 90(6.3)      | 2.64       | 1.2 | 3/8"     | 92             | 0.2              | 1/4"      |

## QE-324

**AIR DRILL**

10 pieces in one carton



## QE-331/QE-332

With keyless chuck

10 pieces in one carton

- QE-331 3/8" AIR REVERSIBLE DRILL
- QE-332 3/8" AIR DRILL



3pcs Planet Gear

## QE-333/QE-334

With key chuck

10 pieces in one carton

- QE-333 3/8" AIR REVERSIBLE DRILL
- QE-334 3/8" AIR DRILL



3pcs Planet Gear

## QE-431/QE-432

With keyless chuck



10 pieces in one carton

- QE-431 3/8" AIR REVERSIBLE DRILL
- QE-432 3/8" AIR DRILL



2pcs Planet Gear with bearing

## QE-433/QE-434

With key chuck



10 pieces in one carton

- QE-433 3/8" AIR REVERSIBLE DRILL
- QE-434 3/8" AIR DRILL



2pcs Planet Gear with bearing

## QE-532

3/8" AIR DRILL With keyless chuck



10 pieces in one carton



3pcs Planet Gear with bearing

## QE-533

3/8" AIR DRILL With key chuck



10 pieces in one carton



3pcs Planet Gear with bearing



## QE-633

3/8" 90° AIR REVERSIBLE DRILL

With keyless chuck



10 pieces in one carton



2pcs Planet Gear with bearing



## QE-634

3/8" 90° AIR ANGLE DRILL

With key chuck



10 pieces in one carton



## QE-831

3/8" AIR REVERSIBLE DRILL

With keyless chuck



10 pieces in one carton



3pcs Planet Gear



## QE-833

3/8" AIR REVERSIBLE DRILL

With key chuck



10 pieces in one carton



3pcs Planet Gear



## QE-933

3/8" AIR REVERSIBLE DRILL

With keyless chuck



20 pieces in one carton



2pcs Planet Gear with bearing



## QE-935

3/8" AIR STRAIGHT DRILL

With key chuck



10 pieces in one carton



2pcs Planet Gear with bearing



Stylized grip

## QE-936

3/8" AIR STRAIGHT DRILL

With key chuck



10 pieces in one carton



Stylized grip

| Item No. | Chuck Size | Free Speed | Motor | Stall Torque | Overall Length | Avg. Air Consumption | Air Pressure | Net Weight |      | Air Hose | Sound Pressure | Vibration Level  | Air Inlet |
|----------|------------|------------|-------|--------------|----------------|----------------------|--------------|------------|------|----------|----------------|------------------|-----------|
|          | inch(mm)   | R.P.M      | HP    | N.m          | inch(mm)       | CFM (L/min)          | PSI (bar)    | LBS        | kg   | Inch     | dBA            | m/s <sup>2</sup> | Inch      |
| QE-324   | 1/4"(6.35) | 5500       | 0.38  | 3.01         | 6-15/32"(164)  | 1.9(54)              | 90(6.3)      | 1.7        | 0.78 | 3/8"     | 74.0           | 1.2              | 1/4"      |
| QE-331   | 3/8"(10)   | 1800       | 0.65  | 6.29         | 8"(203)        | 6.5(184)             | 90(6.3)      | 2.42       | 1.1  | 3/8"     | 96.5           | 0.3              | 1/4"      |
| QE-332   | 3/8"(10)   | 2200       | 0.60  | 6.31         | 7-1/2"(190)    | 6.5(184)             | 90(6.3)      | 2.20       | 1.0  | 3/8"     | 96.5           | 0.3              | 1/4"      |
| QE-333   | 3/8"(10)   | 1800       | 0.65  | 6.29         | 8"(203)        | 6.5(184)             | 90(6.3)      | 2.42       | 1.1  | 3/8"     | 92.0           | 0.2              | 1/4"      |
| QE-334   | 3/8"(10)   | 2200       | 0.60  | 6.31         | 7-1/2"(190)    | 6.5(184)             | 90(6.3)      | 2.20       | 1.0  | 3/8"     | 92.0           | 0.2              | 1/4"      |
| QE-431   | 3/8"(10)   | 1800       | 0.50  | 10.9         | 8-29/32"(226)  | 4.0(112)             | 90(6.3)      | 2.6        | 1.18 | 3/8"     | 90.0           | 3.0              | 1/4"      |
| QE-432   | 3/8"(10)   | 2200       | 0.70  | 8.76         | 8-29/32"(226)  | 4.8(135)             | 90(6.3)      | 2.6        | 1.18 | 3/8"     | 90.0           | 3.0              | 1/4"      |
| QE-433   | 3/8"(10)   | 1800       | 0.50  | 10.9         | 9-1/16"(230)   | 4.0(112)             | 90(6.3)      | 2.7        | 1.23 | 3/8"     | 90.0           | 3.0              | 1/4"      |
| QE-434   | 3/8"(10)   | 2200       | 0.70  | 8.76         | 9-1/16"(230)   | 4.8(135)             | 90(6.3)      | 2.7        | 1.23 | 3/8"     | 90.0           | 3.0              | 1/4"      |
| QE-532   | 3/8"(10)   | 2800       | 0.70  | 8.58         | 9-9/16"(243)   | 4.8(135)             | 90(6.3)      | 2.7        | 1.23 | 3/8"     | 90.0           | 3.0              | 1/4"      |
| QE-533   | 3/8"(10)   | 2200       | 0.50  | 10.58        | 9-13/32"(189)  | 4.0(112)             | 90(6.3)      | 2.7        | 1.23 | 3/8"     | 90.0           | 3.0              | 1/4"      |
| QE-633   | 3/8"(10)   | 1600       | 0.50  | 6.06         | 8-1/4"(210)    | 3.0(85)              | 90(6.3)      | 2.4        | 1.10 | 3/8"     | 72.0           | 2.5              | 1/4"      |
| QE-634   | 3/8"(10)   | 1900       | 0.50  | 6.06         | 8-1/4"(211)    | 5(141)               | 90(6.3)      | 2.35       | 1.07 | 3/8"     | 85.0           | 1.1              | 1/4"      |
| QE-831   | 3/8"(10)   | 1800       | 0.45  | 7.33         | 7-1/4"(185)    | 4.0(113)             | 90(6.3)      | 2.5        | 1.10 | 3/8"     | 83.0           | 0.3              | 1/4"      |
| QE-833   | 3/8"(10)   | 1800       | 0.45  | 7.33         | 7-1/4"(185)    | 4.0(113)             | 90(6.3)      | 2.7        | 1.23 | 3/8"     | 83.0           | 0.3              | 1/4"      |
| QE-933   | 3/8"(10)   | 2600       | 0.50  | 3.85         | 8-15/32"(215)  | 3.0(85)              | 90(6.3)      | 2.0        | 0.90 | 3/8"     | 72.0           | 2.5              | 1/4"      |
| QE-935   | 3/8"(10)   | 4000       | 0.5   | 2.98         | 9"(230)        | 5.0(141)             | 90(6.3)      | 1.89       | 0.86 | 3/8"     | 85.0           | 1.6              | 1/4"      |
| QE-936   | 3/8"(10)   | 22000      | 0.5   | 3.03         | 8-9/16"(218)   | 5.0(141)             | 90(6.3)      | 1.62       | 0.74 | 3/8"     | 85.0           | 1.2              | 1/4"      |

# AIR DRILL

AIR DRILL

## QE-341/QE-342

With keyless chuck

★★    **10 pieces in one carton**

- QE-341 1/2" AIR REVERSIBLE DRILL
- QE-342 1/2" AIR DRILL



3pcs Planet Gear x 2Set

## QE-343/QE-344

With key chuck

★★    **10 pieces in one carton**

- QE-343 1/2" AIR REVERSIBLE DRILL
- QE-344 1/2" AIR DRILL



3pcs Planet Gear x 2Set

## QE-441/QE-442

With keyless chuck

★★★      **10 pieces in one carton**

- QE-441 1/2" AIR REVERSIBLE DRILL
- QE-442 1/2" AIR DRILL



2pcs Planet Gear x 2Set bearing

## QE-443 **10 pieces in one carton**

1/2" AIR REVERSIBLE DRILL

With key chuck

★★★     



2pcs Planet Gear x 2Set bearing

## QE-542 **10 pieces in one carton**

1/2" AIR DRILL With keyless chuck

★★★     



3pcs Planet Gear x 2Set bearing

## QE-543 **10 pieces in one carton**

1/2" AIR REVERSIBLE DRILL

With key chuck

★★★     



3pcs Planet Gear x 2Set bearing

## QE-841 **10 pieces in one carton**

1/2" AIR REVERSIBLE DRILL

With keyless chuck

★★★   



3pcs Planet Gear x 2Set

## QE-843 **10 pieces in one carton**

1/2" AIR REVERSIBLE DRILL

With key chuck

★★★   



3pcs Planet Gear x 2Set

## QE-845 **10 pieces in one carton**

1/2" AIR REVERSIBLE DRILL

With key chuck

★★★   



3pcs Planet Gear x 2Set

| Item No. | Chuck Size | Free Speed | Motor | Stall Torque | Overall Length | Avg. Air Consumption | Air Pressure | Net Weight |      | Air Hose | Sound Pressure | Vibration Level  | Air Inlet |
|----------|------------|------------|-------|--------------|----------------|----------------------|--------------|------------|------|----------|----------------|------------------|-----------|
|          | inch(mm)   | R.P.M      | HP    | N.m          | inch(mm)       | CFM (L/min)          | PSI (bar)    | LBS        | kg   | Inch     | dB(A)          | m/s <sup>2</sup> | Inch      |
| QE-341   | 1/2"(13)   | 800        | 0.65  | 11.15        | 9"(230)        | 6.5(184)             | 90(6.3)      | 3.96       | 1.8  | 3/8"     | 96.5           | 0.1              | 1/4"      |
| QE-342   | 1/2"(13)   | 800        | 0.60  | 11.03        | 8-1/4"(209)    | 6.5(184)             | 90(6.3)      | 3.74       | 1.7  | 3/8"     | 96.5           | 0.1              | 1/4"      |
| QE-343   | 1/2"(13)   | 800        | 0.65  | 11.15        | 9"(230)        | 6.5(184)             | 90(6.3)      | 3.96       | 1.8  | 3/8"     | 97.5           | 0.1              | 1/4"      |
| QE-344   | 1/2"(13)   | 800        | 0.60  | 11.03        | 8-1/4"(209)    | 6.5(184)             | 90(6.3)      | 3.74       | 1.7  | 3/8"     | 97.5           | 0.1              | 1/4"      |
| QE-441   | 1/2"(13)   | 1100       | 0.50  | 14.68        | 10-5/8"(270)   | 4.0(112)             | 90(6.3)      | 3.5        | 1.58 | 3/8"     | 90.0           | 3.0              | 1/4"      |
| QE-442   | 1/2"(13)   | 1300       | 0.70  | 13.54        | 10-5/8"(270)   | 4.8(135)             | 90(6.3)      | 3.5        | 1.58 | 3/8"     | 90.0           | 3.0              | 1/4"      |
| QE-443   | 1/2"(13)   | 1100       | 0.50  | 14.68        | 10-5/8"(270)   | 4.0(112)             | 90(6.3)      | 3.8        | 1.73 | 3/8"     | 90.0           | 3.0              | 1/4"      |
| QE-542   | 1/2"(13)   | 1300       | 0.70  | 15.89        | 11"(280)       | 4.8(135)             | 90(6.3)      | 3.8        | 1.73 | 3/8"     | 90.0           | 3.0              | 1/4"      |
| QE-543   | 1/2"(13)   | 1100       | 0.50  | 14.89        | 10-7/8"(276)   | 4.0(112)             | 90(6.3)      | 3.8        | 1.73 | 3/8"     | 90.0           | 3.0              | 1/4"      |
| QE-841   | 1/2"(13)   | 800        | 0.45  | 12.58        | 8-1/4"(210)    | 4.0(113)             | 90(6.3)      | 3.7        | 1.7  | 3/8"     | 83.0           | 0.3              | 1/4"      |
| QE-843   | 1/2"(13)   | 800        | 0.45  | 12.58        | 8-1/4"(210)    | 4.0(113)             | 90(6.3)      | 3.9        | 1.8  | 3/8"     | 83.0           | 0.3              | 1/4"      |
| QE-845   | 1/2"(13)   | 500        | 0.45  | 12.83        | 8-1/4"(210)    | 4.0(113)             | 90(6.3)      | 3.9        | 1.8  | 3/8"     | 83.0           | 0.3              | 1/4"      |



**QE-624**  
AIR DRILL

10 pieces in one carton



**QE-624QA [SET]**  
4PCS MINI TOOLS SET

5 pieces in one carton

- QE-624
- QE-924
- QA-101
- QA-601



**QE-924**  
AIR DRILL

10 pieces in one carton



| Item No. | Chuck Size          | Free Speed | Motor | Overall Length | Avg. Air Consumption | Air Pressure | Net Weight |      | Air Hose | Sound Pressure | Vibration Level  | Air Inlet |
|----------|---------------------|------------|-------|----------------|----------------------|--------------|------------|------|----------|----------------|------------------|-----------|
|          | inch(mm)            | R.P.M      | HP    | inch(mm)       | CFM (L/min)          | PSI (bar)    | LBS        | kg   | Inch     | dBa            | m/s <sup>2</sup> | Inch      |
|          |                     |            |       |                |                      |              |            |      |          |                |                  |           |
| QE-624   | 1/4"(6)             | 5000       | 0.3   | 5-5/8"(143)    | 7.8(130)             | 90(6.3)      | 1.47       | 0.67 | 3/8"     | 82             | 1.2              | 1/4"      |
| QE-924   | 1/4"(6)             | 6500       | 0.3   | 5-3/4"(146)    | 8.1(135)             | 90(6.3)      | 1.2        | 0.55 | 3/8"     | 77             | 1.2              | 1/4"      |
| QA-101   | 1/4" & 1/8" (6 & 3) | 25000      | 0.3   | 4-11/16"(119)  | 6.3(105)             | 90(6.3)      | 0.7        | 0.32 | 3/8"     | 80             | 1.4              | 1/4"      |
| QA-601   | 1/4" & 1/8" (6 & 3) | 22000      | 0.3   | 4-3/4"(120.7)  | 10(167)              | 90(6.3)      | 0.97       | 0.44 | 3/8"     | 84             | 1.1              | 1/4"      |

# AIR DRILL

## QE-6030 QE-6030L

**AIR RIGHT ANGLE DRILL**  
Threaded type



## QE-6130 QE-6130L

**AIR RIGHT ANGLE DRILL**  
Threaded type



## QE-6010 QE-6010L

**AIR 45° ANGLE DRILL**  
Threaded type



## QE-6020 QE-6020L

**AIR RIGHT ANGLE DRILL**  
Threaded type



## QE-6120 QE-6120L

**AIR RIGHT ANGLE DRILL**  
Threaded type



## QE-6110 QE-6110L

**AIR 45° ANGLE DRILL**  
Threaded type



| Item No. | Spindle Size | Free Speed | Motor | Overall Length | Avg. Air Consumption | Air Pressure | Net Weight |      | Air Hose | Sound Pressure | Vibration Level  | Air Inlet          |
|----------|--------------|------------|-------|----------------|----------------------|--------------|------------|------|----------|----------------|------------------|--------------------|
|          | inch         | R.P.M      | HP    | inch(mm)       | CFM (L/min)          | PSI (bar)    | LBS        | kg   | Inch     | dBA            | m/s <sup>2</sup> | kg/cm <sup>2</sup> |
| QE-6030  | 1/4"-28      | 4000       | 0.40  | 9-1/2"(240)    | 3.0(84)              | 90(6.3)      | 1.4        | 0.64 | 3/8"     | 81.5           | <2.5             | 1/4"               |
| QE-6030L | 1/4"-28      | 4000       | 0.40  | 12-1/8"(308)   | 3.0(84)              | 90(6.3)      | 1.65       | 0.75 | 3/8"     | 81.5           | <2.5             | 1/4"               |
| QE-6130  | 1/4"-28      | 3600       | 0.60  | 10-1/4"(259)   | 3.5(99)              | 90(6.3)      | 2.2        | 1.0  | 3/8"     | 82             | <2.5             | 1/4"               |
| QE-6130L | 1/4"-28      | 3600       | 0.60  | 12-7/8"(327)   | 3.5(99)              | 90(6.3)      | 2.2        | 1.0  | 3/8"     | 82             | <2.5             | 1/4"               |
| QE-6010  | 1/4"-28      | 4000       | 0.40  | 10"(256)       | 3.0(84)              | 90(6.3)      | 1.4        | 0.64 | 3/8"     | 81.5           | <2.5             | 1/4"               |
| QE-6010L | 1/4"-28      | 4000       | 0.40  | 13-1/8"(333)   | 3.0(84)              | 90(6.3)      | 1.65       | 0.75 | 3/8"     | 81.5           | <2.5             | 1/4"               |
| QE-6020  | 1/4"-28      | 4000       | 0.40  | 9-1/2"(240)    | 3.0(84)              | 90(6.3)      | 1.4        | 0.64 | 3/8"     | 81.5           | <2.5             | 1/4"               |
| QE-6020L | 1/4"-28      | 4000       | 0.40  | 12-1/8"(308)   | 3.0(84)              | 90(6.3)      | 1.65       | 0.75 | 3/8"     | 81.5           | <2.5             | 1/4"               |
| QE-6120  | 1/4"-28      | 3600       | 0.60  | 10-1/4"(259)   | 3.5(99)              | 90(6.3)      | 2.2        | 1.0  | 3/8"     | 82             | <2.5             | 1/4"               |
| QE-6120L | 1/4"-28      | 3600       | 0.60  | 12-7/8"(327)   | 3.5(99)              | 90(6.3)      | 2.2        | 1.0  | 3/8"     | 82             | <2.5             | 1/4"               |
| QE-6110  | 1/4"-28      | 3600       | 0.60  | 10-7/8"(274)   | 3.5(99)              | 90(6.3)      | 1.9        | 0.86 | 3/8"     | 82             | <2.5             | 1/4"               |
| QE-6110L | 1/4"-28      | 3600       | 0.60  | 13-7/8"(351)   | 3.5(99)              | 90(6.3)      | 2.2        | 1.0  | 3/8"     | 82             | <2.5             | 1/4"               |

## QE-6021 QE-6021L

**AIR RIGHT ANGLE DRILL**  
Collect type



## QE-6011 QE-6011L

**AIR 45° ANGLE DRILL**  
Collect type



## QE-6121 QE-6121L

**AIR RIGHT ANGLE DRILL**  
Collect type



## QE-6111 QE-6111L

**AIR 45° ANGLE DRILL**  
Collect type



| Item No. | Spindle Size | Free Speed | Motor | Overall Length | Avg. Air Consumption | Air Pressure | Net Weight |      | Air Hose | Sound Pressure | Vibration Level  | Air Inlet          |
|----------|--------------|------------|-------|----------------|----------------------|--------------|------------|------|----------|----------------|------------------|--------------------|
|          | inch         | R.P.M      | HP    | inch(mm)       | CFM (L/min)          | PSI (bar)    | LBS        | kg   | Inch     | dBA            | m/s <sup>2</sup> | kg/cm <sup>2</sup> |
| QE-6021  | 9/32"-40     | 4000       | 0.40  | 9-1/2"(240)    | 3.0(84)              | 90(6.3)      | 1.4        | 0.64 | 3/8"     | 81.5           | <2.5             | 1/4"               |
| QE-6021L | 9/32"-40     | 4000       | 0.40  | 9-1/2"(240)    | 3.0(84)              | 90(6.3)      | 1.65       | 0.75 | 3/8"     | 81.5           | <2.5             | 1/4"               |
| QE-6011  | 9/32"-40     | 4000       | 0.40  | 10"(256)       | 3.0(84)              | 90(6.3)      | 1.4        | 0.64 | 3/8"     | 81.5           | <2.5             | 1/4"               |
| QE-6011L | 9/32"-40     | 4000       | 0.40  | 13-1/8"(333)   | 3.0(84)              | 90(6.3)      | 1.65       | 0.75 | 3/8"     | 81.5           | <2.5             | 1/4"               |
| QE-6121  | 9/32"-40     | 3600       | 0.60  | 10-1/4"(259)   | 3.5(99)              | 90(6.3)      | 1.9        | 0.86 | 3/8"     | 82             | <2.5             | 1/4"               |
| QE-6121L | 9/32"-40     | 3600       | 0.60  | 12-7/8"(327)   | 3.5(99)              | 90(6.3)      | 2.2        | 1.0  | 3/8"     | 82             | <2.5             | 1/4"               |
| QE-6111  | 9/32"-40     | 3600       | 0.60  | 10-7/8"(274)   | 3.5(99)              | 90(6.3)      | 1.9        | 0.86 | 3/8"     | 82             | <2.5             | 1/4"               |
| QE-6111L | 9/32"-40     | 3600       | 0.60  | 13-7/8"(351)   | 3.5(99)              | 90(6.3)      | 2.2        | 1.0  | 3/8"     | 82             | <2.5             | 1/4"               |

## QE-6022 QE-6022L

**AIR RIGHT ANGLE DRILL**  
Chuck type



## QE-6112 QE-6112L

**AIR 45° ANGLE DRILL**  
Chuck type



## QE-6012 QE-6012L

**AIR 45° ANGLE DRILL**  
Chuck type



## QE-6122 QE-6122L

**AIR RIGHT ANGLE DRILL**  
Chuck type



| Item No. | Chuck Size | Free Speed | Motor | Overall Length | Avg. Air Consumption | Air Pressure | Net Weight |      | Air Hose | Sound Pressure | Vibration Level  | Air Inlet          |
|----------|------------|------------|-------|----------------|----------------------|--------------|------------|------|----------|----------------|------------------|--------------------|
|          | inch(mm)   | R.P.M      | HP    | inch(mm)       | CFM (L/min)          | PSI (bar)    | LBS        | kg   | Inch     | dBA            | m/s <sup>2</sup> | kg/cm <sup>2</sup> |
| QE-6022  | 1/8"(3)    | 4000       | 0.40  | 9-1/2"(240)    | 3.0(84)              | 90(6.3)      | 1.4        | 0.64 | 3/8"     | 81.5           | <2.5             | 1/4"               |
| QE-6022L | 1/8"(3)    | 4000       | 0.40  | 12-1/8"(308)   | 3.0(84)              | 90(6.3)      | 1.65       | 0.75 | 3/8"     | 81.5           | <2.5             | 1/4"               |
| QE-6012  | 1/8"(3)    | 4000       | 0.40  | 10-1/8"(256)   | 3.0(84)              | 90(6.3)      | 1.4        | 0.64 | 3/8"     | 81.5           | <2.5             | 1/4"               |
| QE-6012L | 1/8"(3)    | 4000       | 0.40  | 10-1/4"(333)   | 3.0(84)              | 90(6.3)      | 1.65       | 0.75 | 3/8"     | 81.5           | <2.5             | 1/4"               |
| QE-6122  | 1/8"(3)    | 3600       | 0.60  | 10-1/4"(259)   | 3.5(99)              | 90(6.3)      | 1.9        | 0.86 | 3/8"     | 82             | <2.5             | 1/4"               |
| QE-6122L | 1/8"(3)    | 3600       | 0.60  | 12-7/8"(327)   | 3.5(99)              | 90(6.3)      | 2.2        | 1.0  | 3/8"     | 82             | <2.5             | 1/4"               |
| QE-6112  | 1/8"(3)    | 3600       | 0.60  | 10-3/4"(274)   | 3.5(99)              | 90(6.3)      | 1.9        | 0.86 | 3/8"     | 82             | <2.5             | 1/4"               |
| QE-6112L | 1/8"(3)    | 3600       | 0.60  | 13-7/8"(351)   | 3.5(99)              | 90(6.3)      | 2.2        | 1.0  | 3/8"     | 82             | <2.5             | 1/4"               |



# AIR SCREWDRIVER



Pistol Type

★★★  
Excellent

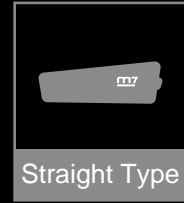

Straight Type

★  
Good

AIR SCREWDRIVER

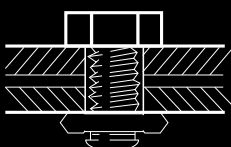
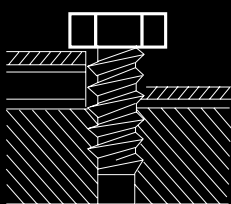
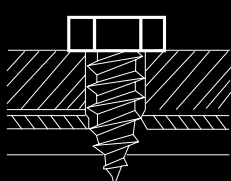
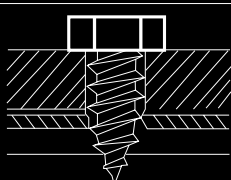
| Joint & Torque Curve   | Clutch Type                 | Model Number                |         |         |         |         |         |  |
|--|-----------------------------|-----------------------------|---------|---------|---------|---------|---------|--|
|  |                             | M3                          | M3.5    | M4      | M5      | M6      | M8      |  |
|  <p>Free Running<br/>Hard stop/soft stop</p>              | ★★★<br>Shut-off Screwdriver | RA-3023                     | RA-3017 | RA-3011 | RA-4008 |         |         |  |
|  |                             |                             | RA-3123 | RA-4015 | RA-5005 |         |         |  |
|  |                             |                             |         | RA-4021 | RA-5008 |         |         |  |
|  |                             |                             |         | RA-5017 | RA-4108 |         |         |  |
|  |                             |                             |         | RA-3111 | RA-4115 |         |         |  |
|  |                             | ★<br>Adjustable Clutch      |         |         | RA-3117 | RA-5015 |         |  |
|  |                             |                             |         | RA-4121 | RA-5108 |         |         |  |
|  |                             |                             |         |         | RA-5117 |         |         |  |
|  |                             |                             |         |         | RA-1131 | RA-1151 | RA-802  |  |
|  |                             |                             |         |         | RA-1132 | RA-2161 | RA-302  |  |
|  <p>Self-Tapping<br/>Thick Material<br/>Sheet Metal</p> | ★★★<br>Adjustable Clutch    |                             |         | RA-1141 |         |         |         |  |
|  |                             |                             |         | RA-1142 |         |         |         |  |
|  |                             |                             |         | RA-1162 |         |         |         |  |
|  |                             |                             |         | RA-301  |         |         |         |  |
|  |                             |                             |         | RA-801  |         |         |         |  |
|  |                             | ★<br>Twin Dog & Twin Hammer |         |         | RA-1131 | RA-1151 | RA-802  |  |
|  |                             |                             |         | RA-1132 | RA-2161 | RA-302  |         |  |
|  |                             |                             |         | RA-1232 | RA-2242 | RA-606  | RA-2272 |  |
|  |                             |                             |         | RA-1242 | RA-102  | RA-201  | RA-608  |  |
|  |                             |                             |         | RA-101  |         | RA-110  | RA-1272 |  |
|  <p>Self-Tapping<br/>Plastic</p>                        | ★★★<br>Adjustable Clutch    |                             |         | RA-101C |         | RA-105  | RA-111  |  |
|  |                             |                             |         | RA-1131 | RA-1151 | RA-802  |         |  |
|  |                             |                             |         | RA-1132 | RA-2161 | RA-302  |         |  |
|  |                             |                             |         | RA-1141 |         |         |         |  |
|  |                             |                             |         | RA-1142 |         |         |         |  |
|  |                             | ★<br>Twin Dog               |         |         | RA-1162 |         |         |  |
|  |                             |                             |         | RA-301  |         |         |         |  |
|  |                             |                             |         | RA-801  |         |         |         |  |
|  |                             |                             |         | RA-1232 | RA-2242 | RA-606  | RA-2272 |  |
|  |                             |                             |         | RA-1242 | RA-102  | RA-201  | RA-608  |  |
|  <p>Wood screws</p>                                     | ★★★<br>Positive Clutch      |                             |         |         |         | RA-811  |         |  |
|  |                             |                             |         |         |         | RA-402  |         |  |
|  |                             | ★<br>Twin Dog               |         |         | RA-101C |         |         |  |
|  |                             |                             |         | RA-1232 | RA-2242 | RA-606  | RA-2272 |  |
|  |                             |                             |         | RA-1242 | RA-102  | RA-201  | RA-608  |  |
|  |                             |                             |         | RA-101  |         | RA-105  | RA-1272 |  |

## Clutch Type Series

Extmal Adjatment

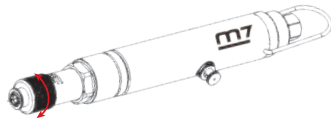

### RA-1131

**AIR SCREWDRIVER ADJUSTABLE CLUTCH**  
Screw capacity : M4



10 pieces in one carton

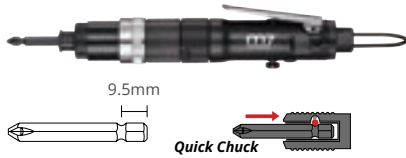

### RA-1141

**AIR SCREWDRIVER ADJUSTABLE CLUTCH**  
Screw capacity : M4



10 pieces in one carton

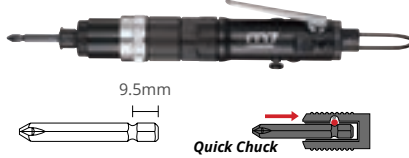

### RA-1151

**AIR SCREWDRIVER ADJUSTABLE CLUTCH**  
Screw capacity : M5



10 pieces in one carton

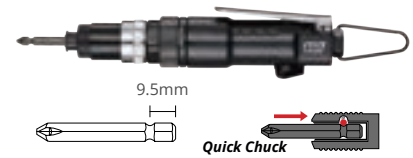

### RA-2161

**AIR SCREWDRIVER ADJUSTABLE CLUTCH**  
Screw capacity : M5



10 pieces in one carton

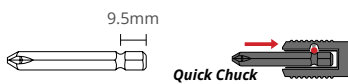

### RA-801ET

**AIR SCREWDRIVER EXTERNAL ADJUSTABLE**  
Screw capacity : M4



10 pieces in one carton

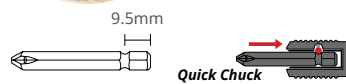

## Impact Type Series

Twin Dog Type



### RA-101 RA-101C

Twin dog type  
Screw capacity : M4



20 pieces in one carton

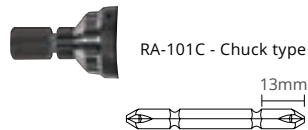

### RA-102

Twin dog type  
Screw capacity : M5



20 pieces in one carton



### RA-105

Twin dog type  
Screw capacity : M6



12 pieces in one carton

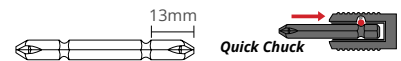

### RA-110

Twin hammer type  
Screw capacity : M6



12 pieces in one carton

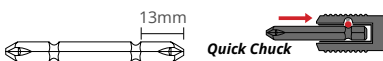

### RA-1232

Twin dog type  
Screw capacity : M4



10 pieces in one carton

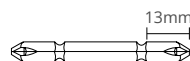

### RA-1242

Twin dog type  
Screw capacity : M4



10 pieces in one carton

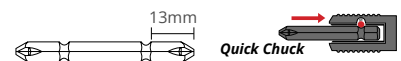

# AIR SCREWDRIVER

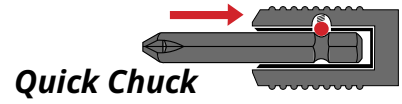

## RA-1272

Twin dog type  
Screw capacity : M8



10 pieces in one carton

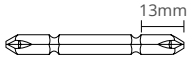

## RA-608

Twin dog type  
Screw capacity : M8



12 pieces in one carton

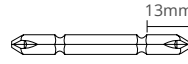

## RA-201

Twin dog type  
Screw capacity : M8



8 pieces in one carton

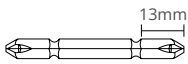

## RA-606

Twin dog type  
Screw capacity : M6



12 pieces in one carton

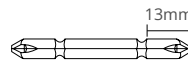

## RA-2242

Twin dog type  
Screw capacity : M5



10 pieces in one carton

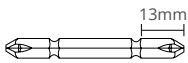

## RA-2272

Twin dog type  
Screw capacity : M8



10 pieces in one carton

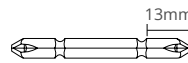

| Item No. | Bit Size   | Torque Range     | Free Speed | Overall Length | Avg. Air Consumption | Air Pressure | Net Weight |      | Air Hose | Sound Pressure | Vibration Level  | Air Inlet |
|----------|------------|------------------|------------|----------------|----------------------|--------------|------------|------|----------|----------------|------------------|-----------|
|          | inch(mm)   | FT-LB(Nm)        | R.P.M      | inch(mm)       | CFM (L/min)          | PSI (bar)    | LBS        | kg   | Inch     | dB(A)          | m/s <sup>2</sup> | Inch      |
| RA-1131  | 1/4"(6.35) | 0.7-2.9(1-4)     | 1800       | 9"(228)        | 4.5(127)             | 90(6.3)      | 1.6        | 0.76 | 3/8"     | 80.0           | 2.3              | 1/4"      |
| RA-1141  | 1/4"(6.35) | 0.7-2.2(1-3)     | 800        | 8-7/8"(226)    | 4.5(127)             | 90(6.3)      | 1.6        | 0.76 | 3/8"     | 80.0           | 2.3              | 1/4"      |
| RA-1151  | 1/4"(6.35) | 1.4-3.7(2-5)     | 1900       | 9-1/32"(229)   | 4.5(127)             | 90(6.3)      | 2.2        | 1.01 | 3/8"     | 85.0           | 2.3              | 1/4"      |
| RA-2161  | 1/4"(6.35) | 1.4-3.7(2-5)     | 750        | 7-15/32"(190)  | 7.5(212)             | 90(6.3)      | 2.0        | 1.00 | 3/8"     | 80.0           | 2.0              | 1/4"      |
| RA-801ET | 1/4"(6.35) | 3.8-10.4(5-14)   | 1700       | 7-4/5"(198)    | 17.5(496)            | 90(6.3)      | 2.65       | 1.20 | 1/4"     | 93.6           | 1.35             | 1/4"      |
| RA-101   | 1/4"(6.35) | 3.7-8.9(5-12)    | 9000       | 6-1/2"(166)    | 6.0(170)             | 90(6.3)      | 1.32       | 0.6  | 3/8"     | 85.7           | 2.2              | 1/4"      |
| RA-102   | 1/4"(6.35) | 3.7-10.3(5-14)   | 9000       | 6-3/4"(172)    | 6.0(170)             | 90(6.3)      | 1.54       | 0.7  | 3/8"     | 86.7           | 3.7              | 1/4"      |
| RA-105   | 1/4"(6.35) | 3.7-16.2(5-22)   | 8500       | 8-1/4"(208)    | 8.5(241)             | 90(6.3)      | 2.20       | 1.0  | 3/8"     | 96.7           | 4.9              | 1/4"      |
| RA-110   | 1/4"(6.35) | 3.7-29.5(5-40)   | 8500       | 8-1/4"(208)    | 8.5(241)             | 90(6.3)      | 2.20       | 1.0  | 3/8"     | 96.7           | 4.9              | 1/4"      |
| RA-1232  | 1/4"(6.35) | 11-22(15-30)     | 9000       | 7-11/16"(195)  | 4.5(127)             | 90(6.3)      | 1.47       | 0.67 | 3/8"     | 80.0           | 3.2              | 1/4"      |
| RA-1242  | 1/4"(6.35) | 14-22(19-30)     | 12500      | 6-11/16"(170)  | 5.0(141)             | 90(6.3)      | 1.25       | 0.57 | 3/8"     | 89.0           | 3.9              | 1/4"      |
| RA-1272  | 1/4"(6.35) | 44-177(60-240)   | 8000       | 7-27/32"(200)  | 9.0(255)             | 90(6.3)      | 2.30       | 1.06 | 3/8"     | 97.0           | 5.1              | 1/4"      |
| RA-201   | 1/4"(6.35) | 3.7-18.5(5-25)   | 10000      | 7"(180)        | 9.0(255)             | 90(6.3)      | 2.65       | 1.2  | 3/8"     | 93.0           | 5.3              | 1/4"      |
| RA-606   | 1/4"(6.35) | 3.7-33.2(5-45)   | 8000       | 7-4/5"(198)    | 5.6(160)             | 90(6.3)      | 2.2        | 1.0  | 3/8"     | 82.0           | 2.2              | 1/4"      |
| RA-608   | 1/4"(6.35) | 3.7-42.8(5-58)   | 8000       | 8-9/16"(217)   | 4.6(130)             | 90(6.3)      | 2.86       | 1.3  | 3/8"     | 86.0           | 3.5              | 1/4"      |
| RA-2242  | 1/4"(6.35) | 18-26(24.4-35.2) | 13000      | 5-15/16"(150)  | 7.0(198)             | 90(6.3)      | 2.0        | 0.9  | 3/8"     | 88.0           | 2.7              | 1/4"      |
| RA-2272  | 1/4"(6.35) | 44-177(59-240)   | 7700       | 7-11/16"(195)  | 8.5(240)             | 90(6.3)      | 3.0        | 1.38 | 3/8"     | 93.0           | 4.9              | 1/4"      |

# Clutch Type Series

Internal Adjustment

Quick Chuck

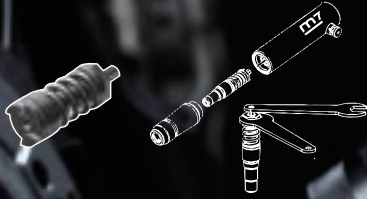
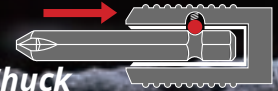

## RA-1132

**ADJUSTABLE CLUTCH**

Screw capacity : M4



10 pieces in one carton



## RA-1142

**ADJUSTABLE CLUTCH**

Screw capacity : M4



10 pieces in one carton

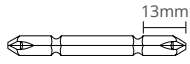

## RA-1162

**ADJUSTABLE CLUTCH**

Screw capacity : M6



10 pieces in one carton

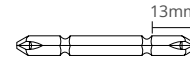

## RA-301

**ADJUSTABLE CLUTCH**

Screw capacity : M4



10 pieces in one carton

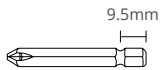

Quick Chuck

## RA-302

**ADJUSTABLE CLUTCH**

Screw capacity : M6



10 pieces in one carton

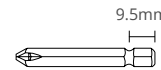

Quick Chuck

## RA-801

**ADJUSTABLE CLUTCH**

Screw capacity : M4



10 pieces in one carton

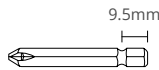

Quick Chuck

## RA-802

**ADJUSTABLE CLUTCH**

Screw capacity : M6



10 pieces in one carton

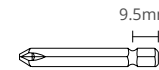

Quick Chuck

| Item No. | Bit Size   | Torque Range   | Free Speed | Overall Length | Avg. Air Consumption | Air Pressure | Net Weight |      | Air Hose | Sound Pressure | Vibration Level  | Air Inlet |
|----------|------------|----------------|------------|----------------|----------------------|--------------|------------|------|----------|----------------|------------------|-----------|
|          | inch(mm)   | FT-LB(Nm)      | R.P.M      | inch(mm)       | CFM (L/min)          | PSI (bar)    | LBS        | kg   | Inch     | dBA            | m/s <sup>2</sup> | Inch      |
| RA-1132  | 1/4"(6.35) | 0.7-2.2(1-3)   | 2200       | 9-7/32"(235)   | 6.0(170)             | 90(6.3)      | 1.7        | 0.8  | 3/8"     | 80.0           | 2.3              | 1/4"      |
| RA-1142  | 1/4"(6.35) | 0.7-2.2(1-3)   | 1700       | 9-7/32"(235)   | 5.0(141)             | 90(6.3)      | 1.34       | 0.61 | 3/8"     | 80.0           | 2.0              | 1/4"      |
| RA-1162  | 1/4"(6.35) | 1.5-5.9(2-8)   | 600        | 10-7/16"(265)  | 6.0(170)             | 90(6.3)      | 2.1        | 0.95 | 3/8"     | 90.0           | 2.2              | 1/4"      |
| RA-301   | 1/4"(6.35) | 3.8-10(5-13.5) | 1800       | 7-1/2"(190)    | 6.0(170)             | 90(6.3)      | 2.40       | 1.1  | 3/8"     | 95.3           | 4.2              | 1/4"      |
| RA-302   | 1/4"(6.35) | 3.8-12(5-16.3) | 800        | 9"(226)        | 6.0(170)             | 90(6.3)      | 2.87       | 1.3  | 3/8"     | 96.5           | 2.2              | 1/4"      |
| RA-801   | 1/4"(6.35) | 3.8-10.4(5-14) | 1800       | 7-3/4"(195)    | 4.0(113)             | 90(6.3)      | 2.70       | 1.22 | 3/8"     | 83.0           | 4.2              | 1/4"      |
| RA-802   | 1/4"(6.35) | 3.8-13.3(5-18) | 800        | 8-9/32"(210)   | 4.0(113)             | 90(6.3)      | 2.80       | 1.30 | 3/8"     | 83.0           | 4.2              | 1/4"      |

AIR SCREWD RIVER

# AIR SCREWDRIVER

**Positive Clutch Type**  
Non - Adjustable

## RA-402

**POSITIVE CLUTCH TYPE**  
Screw capacity : M6



10 pieces in one carton

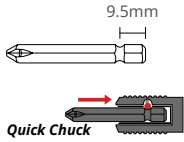

## RA-811

**POSITIVE CLUTCH TYPE**  
Screw capacity : M6



10 pieces in one carton

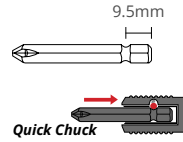

**Torque Control or Shut-off**

## RA-31/RA-41/RA-51 SERIES

**SHUT-OFF SCREWDRIVER**



12 pieces in one carton

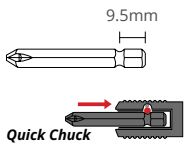

## RA-30/RA-40/RA-50 SERIES

**SHUT-OFF SCREWDRIVER**



12 pieces in one carton

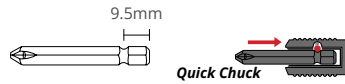

## ZT-31

**DIGITAL TORQUE TESTER**  
Torque range 0-14.7Nm

1 pieces in one carton



| Item No. | Bit Size   | Torque Range        | Free Speed | Overall Length | Avg. Air Consumption | Air Pressure | Net Weight |      | Air Hose | Sound Pressure | Vibration Level  | Air Inlet |
|----------|------------|---------------------|------------|----------------|----------------------|--------------|------------|------|----------|----------------|------------------|-----------|
|          | inch(mm)   | FT-LB(Nm)           | R.P.M      | inch(mm)       | CFM (L/min)          | PSI (bar)    | LBS        | kg   | Inch     | dBA            | m/s <sup>2</sup> | Inch      |
| RA-402   | 1/4"(6.35) | 5-14(6-19)          | 2200       | 7-3/32"(180)   | 3.9(111)             | 90(6.3)      | 2.47       | 1.1  | 3/8"     | 91.0           | 2.3              | 1/4"      |
| RA-811   | 1/4"(6.35) | 5.0-13.0(6-17)      | 2100       | 7"(178)        | 4.0(113)             | 90(6.3)      | 2.50       | 1.13 | 3/8"     | 83.0           | 3.7              | 1/4"      |
| RA-3011  | 1/4"(6.35) | 9.7-18.6(1.1-2.1)   | 1100       | 7-3/8"(187)    | 3.2(90.6)            | 90(6.3)      | 0.94       | 0.42 | 1/4"     | 70.0           | 2.0              | 1/4"      |
| RA-3017  | 1/4"(6.35) | 6.2-13.3(0.7-1.5)   | 1700       | 7-3/8"(187)    | 3.2(90.6)            | 90(6.3)      | 0.94       | 0.42 | 1/4"     | 70.0           | 2.0              | 1/4"      |
| RA-3023  | 1/4"(6.35) | 3.5-8.8(0.4-1.0)    | 2300       | 7-3/8"(187)    | 3.2(90.6)            | 90(6.3)      | 0.94       | 0.42 | 1/4"     | 70.0           | 2.0              | 1/4"      |
| RA-4008  | 1/4"(6.35) | 14.1-35.4(1.6-4.0)  | 800        | 8-1/4"(209)    | 3.7(104.8)           | 90(6.3)      | 1.43       | 0.65 | 1/4"     | 74.0           | 2.5              | 1/4"      |
| RA-4015  | 1/4"(6.35) | 8.8-19.5(1.0-2.2)   | 1500       | 8-1/4"(209)    | 3.7(104.8)           | 90(6.3)      | 1.43       | 0.65 | 1/4"     | 74.0           | 2.5              | 1/4"      |
| RA-4021  | 1/4"(6.35) | 8.8-15(1.0-1.7)     | 2100       | 8-1/4"(209)    | 3.7(104.8)           | 90(6.3)      | 1.43       | 0.65 | 1/4"     | 74.0           | 2.5              | 1/4"      |
| RA-5005  | 1/4"(6.35) | 44.2-92.9(5.0-10.5) | 480        | 9-1/2"(240)    | 4.0(113)             | 90(6.3)      | 2.2        | 1.0  | 3/8"     | 75.0           | 10               | 1/4"      |
| RA-5008  | 1/4"(6.35) | 26.5-48.7(3.0-5.5)  | 800        | 9-1/2"(240)    | 4.0(113)             | 90(6.3)      | 2.2        | 1.0  | 3/8"     | 75.0           | 10               | 1/4"      |
| RA-5017  | 1/4"(6.35) | 13.3-23.0(1.5-2.6)  | 1700       | 9-1/2"(240)    | 4.0(113)             | 90(6.3)      | 2.2        | 1.0  | 3/8"     | 75.0           | 10               | 1/4"      |
| RA-3111  | 7/64"(2.6) | 9.7-18.5(1.1-2.1)   | 1100       | 6-11/16"(170)  | 7.0(198)             | 90(6.3)      | 1.57       | 0.71 | 1/4"     | 82.0           | 0.73             | 1/4"      |
| RA-3117  | 1/4"(6.35) | 6.2-13.2(0.7-1.5)   | 1700       | 6-11/16"(170)  | 7.0(198)             | 90(6.3)      | 1.57       | 0.71 | 1/4"     | 84.0           | 1.51             | 1/4"      |
| RA-3123  | 1/4"(6.35) | 3.5-8.8(0.4-1.0)    | 2300       | 6-11/16"(170)  | 7.0(198)             | 90(6.3)      | 1.57       | 0.71 | 1/4"     | 84.0           | 1.34             | 1/4"      |
| RA-4108  | 1/4"(6.35) | 14.1-35.2(1.6-4.0)  | 800        | 6-15/16"(175)  | 10.5(297)            | 90(6.3)      | 1.92       | 0.87 | 1/4"     | 87.5           | 1.18             | 1/4"      |
| RA-4115  | 1/4"(6.35) | 8.8-19.4(1.0-2.2)   | 1500       | 6-15/16"(175)  | 10.5(297)            | 90(6.3)      | 1.92       | 0.87 | 1/4"     | 85.5           | 1.59             | 1/4"      |
| RA-4121  | 1/4"(6.35) | 8.8-13.2(1.0-1.7)   | 2100       | 6-15/16"(175)  | 10.5(297)            | 90(6.3)      | 1.92       | 0.87 | 1/4"     | 86.8           | 1.61             | 1/4"      |
| RA-5105  | 1/4"(6.35) | 44-92.4(5.0-10.5)   | 480        | 7-4/5"(198)    | 17.5(496)            | 90(6.3)      | 2.65       | 1.20 | 1/4"     | 93.1           | 0.48             | 1/4"      |
| RA-5108  | 1/4"(6.35) | 26.4-48.4(3.0-5.5)  | 800        | 7-4/5"(198)    | 17.5(496)            | 90(6.3)      | 2.65       | 1.20 | 1/4"     | 93.6           | 0.93             | 1/4"      |
| RA-5117  | 1/4"(6.35) | 13.2-23(1.5-2.6)    | 1700       | 7-4/5"(198)    | 17.5(496)            | 90(6.3)      | 2.65       | 1.20 | 1/4"     | 93.6           | 1.35             | 1/4"      |

# SPRING BALANCER

## SP-3400 SP-3500

2 pieces in one carton



## SP-3600 SP-3700 SP-3900 SP-31050 SP-31200

2 pieces in one carton

SP-3600/SP-3700

1 pieces in one carton

SP-3900/SP-31050/SP-31200



## SP-3050/SP-3070 SP-3090/SP-3150 SP-3220/SP-3300

10 pieces in one carton

SP-3050/SP-3070

4 pieces in one carton

SP-3090/SP-3150

2 pieces in one carton

SP-3220/SP-3300



## SP-101/SP-102 SP-103/SP-104 SP-105/SP-111 SP-112/SP-113

30 pieces in one carton



## SP-212 SP-213

30 pieces in one carton



| Item No. | Capacity  | Travel | Rope  | Rope Dia | Weight |
|----------|-----------|--------|-------|----------|--------|
|          | kg        | m      |       | mm       | kg     |
|          |           |        |       |          |        |
| SP-3400  | 30-40     | 1.5    | Cable | 4.8      | 9.7    |
| SP-3500  | 40-50     | 1.5    | Cable | 4.8      | 10.1   |
| SP-3600  | 50-60     | 1.5    | Cable | 4.8      | 11.1   |
| SP-3700  | 60-70     | 1.5    | Cable | 4.8      | 11.4   |
| SP-3900  | 70-90     | 2      | Cable | 4.8      | 22.2   |
| SP-31050 | 90-105    | 2      | Cable | 4.8      | 23.8   |
| SP-31200 | 105-120   | 2      | Cable | 4.8      | 27.4   |
| SP-3050  | 3.0-5.0   | 1.3    | Cable | 3.2      | 1.82   |
| SP-3070  | 5.0-7.0   | 1.3    | Cable | 3.0      | 1.85   |
| SP-3090  | 5.0-9.0   | 1.3    | Cable | 4.0      | 3.59   |
| SP-3150  | 9.0-15.0  | 1.3    | Cable | 4.0      | 3.61   |
| SP-3220  | 15.0-22.0 | 1.3    | Cable | 4.8      | 7.7    |
| SP-3300  | 22.0-30.0 | 1.3    | Cable | 4.8      | 8.3    |
| SP-101   | 0.3-0.8   | 1.4    | Cable | 2.5      | 0.49   |
| SP-102   | 0.6-1.5   | 1.4    | Cable | 2.5      | 0.52   |
| SP-103   | 1.0-2.0   | 1.4    | Cable | 2.5      | 0.53   |
| SP-104   | 1.5-3.0   | 1.4    | Cable | 3.2      | 0.76   |
| SP-105   | 3.0-5.0   | 1.4    | Cable | 3.2      | 0.81   |
| SP-111   | 0.3-0.8   | 1.4    | Nylon | 4.0      | 0.49   |
| SP-112   | 0.6-1.5   | 1.4    | Nylon | 4.0      | 0.52   |
| SP-113   | 1.0-2.0   | 1.4    | Nylon | 4.0      | 0.53   |
| SP-212   | 0.3-1.2   | 1.4    | Nylon | 4.0      | 0.57   |
| SP-213   | 0.8-2.0   | 1.4    | Nylon | 4.0      | 0.57   |

# AIR HAMMER

## SC-331C AIR HAMMER ROUND SHANK

★★    10 pieces in one carton



## SC-341C AIR HAMMER HEX SHANK LOW VIBRATION AIR HAMMER

★★    10 pieces in one carton

- SC-4 chisel kit is provided along with the tool.

## SC-211C AIR HAMMER ROUND SHANK

★★    8 pieces in one carton



## SC-221C AIR HAMMER HEX SHANK

★★    8 pieces in one carton

- SC-4 chisel kit is provided along with the tool.

## SC-371 AIR HAMMER

★★     8 pieces in one carton

- Do not include the chisel



## SC-371C AIR HAMMER

★★     8 pieces in one carton

- Include the chisel

## SC-332C AIR HAMMER ROUND SHANK

★★    10 pieces in one carton



## SC-342C AIR HAMMER HEX SHANK LOW VIBRATION AIR HAMMER

★★    10 pieces in one carton

- SC-4 chisel kit is provided along with the tool.

## SC-212C AIR HAMMER ROUND SHANK

★★    8 pieces in one carton



## SC-222C AIR HAMMER HEX SHANK

★★    8 pieces in one carton

- SC-4 chisel kit is provided along with the tool.

### HAMMER CHISEL

SC-9406R 3/16" SC-9405R 5/32" SC-9404R 1/8" SC-9403R 3/32" SC-9432R 1"



## SC-05C[SET]/SC-06C[SET]

- 1pc- Air Hammer (Various Selections) 5 pieces in one carton
- 5pcs-Chisel Kits
- 1pc- Spring Retainer

| Item No. | Shank       | Contents |
|----------|-------------|----------|
| SC-0517C | Round Shank | SC-211C  |
| SC-0527C | Round Shank | SC-212C  |
| Item No. | Shank       | Contents |
| SC-0617C | Hex Shank   | SC-221C  |
| SC-0627C | Hex Shank   | SC-222C  |



## SC-33C/SC-34C

NEEDLE SCALER ADAPTOR FOR AIR HAMMER TOOLS USE ROUND/HEX  
19pcs Ø 3 mm x 180 mm

20 pieces in one carton

| Item No. | Shank       |
|----------|-------------|
| SC-33C   | Round Shank |
| SC-34C   | Hex Shank   |



- SC-33C - / Round
- SC-34C - / Hex

## SN-1032 AIR FLUX CHIPPER

★★    12 pieces in one carton

- Include the chisel



## SN-9101/SN-9103 SN-9201/SN-9203 CHISEL FOR SN-31/SN-32 SERIES

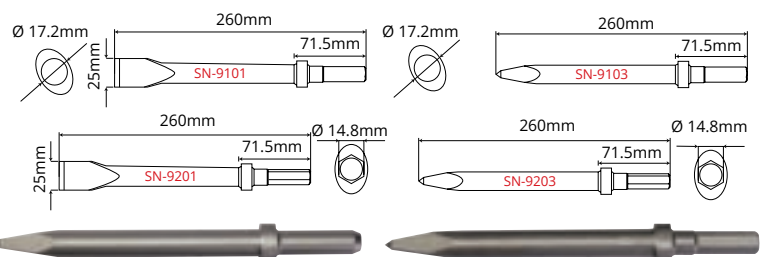

| Item No. | Shank | Chunk Size | Stroke Length | Blow Minute | Avg. Air Consumption | Air Pressure | Overall Length | Net Weight |     | Air Hose | Sound Pressure | Vibration Level  | Air Inlet |
|----------|-------|------------|---------------|-------------|----------------------|--------------|----------------|------------|-----|----------|----------------|------------------|-----------|
|          |       | inch(mm)   | mm            | b.p.m       | CFM (L/min)          | PSI (bar)    | inch(mm)       | LBS        | kg  | Inch     | dBA            | m/s <sup>2</sup> | Inch      |
|          |       |            |               | <b>bpm</b>  |                      |              |                |            |     |          |                |                  |           |
| SC-211C  | ●     | 3/8"(10.2) | 67            | 3200        | 4.0(113)             | 90(6.3)      | 6-7/8"(175)    | 3.7        | 1.7 | 3/8"     | 98.0           | 12.3             | 1/4"      |
| SC-221C  | ●     | 3/8"(10)   | 67            | 3200        | 4.0(113)             | 90(6.3)      | 6-7/8"(175)    | 3.7        | 1.7 | 3/8"     | 98.0           | 12.3             | 1/4"      |
| SC-212C  | ●     | 3/8"(10.2) | 89            | 2200        | 4.0(113)             | 90(6.3)      | 8-7/8"(225)    | 4.4        | 2.0 | 3/8"     | 94.7           | 13.2             | 1/4"      |
| SC-222C  | ●     | 3/8"(10)   | 89            | 2200        | 4.0(113)             | 90(6.3)      | 8-7/8"(225)    | 4.4        | 2.0 | 3/8"     | 94.7           | 13.2             | 1/4"      |
| SC-331C  | ●     | 3/8"(10.2) | 71            | 3000        | 7.8(220)             | 90(6.3)      | 7-31/64"(190)  | 3.7        | 1.7 | 1/4"     | 92.0           | 9.5              | 1/4"      |
| SC-332C  | ●     | 3/8"(10.2) | 92            | 2200        | 8.2(232)             | 90(6.3)      | 8-63/64"(228)  | 4.4        | 2.0 | 3/8"     | 94.0           | 10.6             | 1/4"      |
| SC-341C  | ●     | 3/8"(10)   | 71            | 3000        | 7.8(190)             | 90(6.3)      | 7-31/64"(190)  | 3.7        | 1.7 | 3/8"     | 92.0           | 9.5              | 1/4"      |
| SC-342C  | ●     | 3/8"(10)   | 92            | 2200        | 8.2(232)             | 90(6.3)      | 8-63/64"(228)  | 4.4        | 2.0 | 3/8"     | 94.0           | 10.6             | 1/4"      |
| SC-371   | ●     | 3/8"(10.2) | 62.5          | 3000        | 7.8(180)             | 90(6.3)      | 7-1/8"(180)    | 3.7        | 1.7 | 3/8"     | 95.0           | 8.8              | 1/4"      |

## SN-3111C/SN-3112C SN-3113C/SN-3114C

ROUND SHANK



2 pieces in one carton

## SN-3121C/SN-3122C SN-3123C/SN-3124C

HEX SHANK



2 pieces in one carton

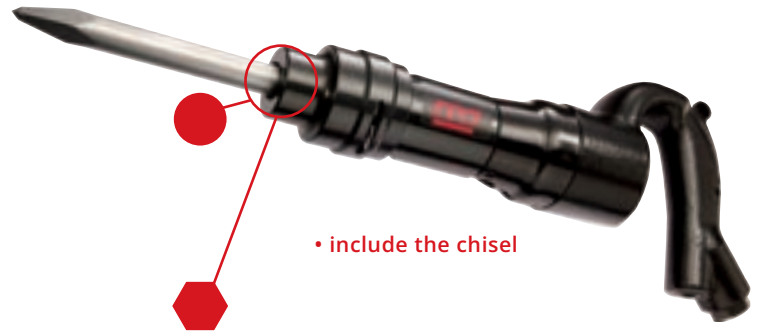

• include the chisel

## SN-3212C/SN-3213C SN-3214C

ROUND SHANK



2 pieces in one carton

## SN-3222C/SN-3223C SN-3224C

HEX SHANK



2 pieces in one carton



• include the chisel

| Item No. | Shank | Chunk Size | Stroke Length | Blow Minute | Avg. Air Consumption | Air Pressure | Overall Length | Net Weight |      | Air Hose | Sound Pressure | Vibration Level  | Air Inlet |
|----------|-------|------------|---------------|-------------|----------------------|--------------|----------------|------------|------|----------|----------------|------------------|-----------|
|          |       | inch(mm)   | mm            | b.p.m       | CFM (L/min)          | PSI (bar)    | inch(mm)       | LBS        | kg   | Inch     | dBA            | m/s <sup>2</sup> | Inch      |
|          |       |            |               | <b>bpm</b>  |                      |              |                |            |      |          |                |                  |           |
| SN-1032  | ■     | 0.51(13)   | 33            | 4000        | 4.23(120)            | 90(6.3)      | 11-1/2"(290)   | 2.9        | 1.33 | 3/8"     | 91.0           | 14.5             | 1/4"      |
| SN-3111C | ●     | 0.68(17.2) | 75            | 2500        | 10.0(283)            | 90(6.3)      | 15-1/2"(395)   | 15.4       | 7.0  | 1/2"     | 115.3          | 8.0              | 1/2"      |
| SN-3121C | ●     | 0.58(14.8) | 75            | 2500        | 10.0(283)            | 90(6.3)      | 15-1/2"(395)   | 15.4       | 7.0  | 1/2"     | 115.3          | 8.0              | 1/2"      |
| SN-3112C | ●     | 0.68(17.2) | 90            | 2300        | 20.0(566)            | 90(6.3)      | 16"(405)       | 16.1       | 7.3  | 1/2"     | 114.3          | 9.4              | 1/2"      |
| SN-3122C | ●     | 0.58(14.8) | 90            | 2300        | 20.0(566)            | 90(6.3)      | 16"(405)       | 16.1       | 7.3  | 1/2"     | 114.3          | 9.4              | 1/2"      |
| SN-3113C | ●     | 0.68(17.2) | 127           | 2000        | 22.0(622.6)          | 90(6.3)      | 17-3/4"(450)   | 17.6       | 8.0  | 1/2"     | 113.3          | 4.8              | 1/2"      |
| SN-3123C | ●     | 0.58(14.8) | 127           | 2000        | 22.0(622.6)          | 90(6.3)      | 17-3/4"(450)   | 17.6       | 8.0  | 1/2"     | 113.3          | 4.8              | 1/2"      |
| SN-3114C | ●     | 0.68(17.2) | 154           | 1600        | 24.0(679.2)          | 90(6.3)      | 18-1/2"(470)   | 18.3       | 8.3  | 1/2"     | 114.1          | 6.2              | 1/2"      |
| SN-3124C | ●     | 0.58(14.8) | 154           | 1600        | 24.0(679.2)          | 90(6.3)      | 18-1/2"(470)   | 18.3       | 8.3  | 1/2"     | 114.1          | 6.2              | 1/2"      |
| SN-3212C | ●     | 0.68(17.2) | 78            | 2300        | 20.0(566)            | 90(6.3)      | 14-5/8"(373)   | 17.2       | 7.8  | 1/2"     | 114.3          | 9.4              | 1/2"      |
| SN-3222C | ●     | 0.58(14.8) | 78            | 2300        | 20.0(566)            | 90(6.3)      | 14-5/8"(373)   | 17.2       | 7.8  | 1/2"     | 114.3          | 9.4              | 1/2"      |
| SN-3213C | ●     | 0.68(17.2) | 119           | 1900        | 22.0(622.6)          | 90(6.3)      | 16-1/2"(419)   | 18.7       | 8.5  | 1/2"     | 113.3          | 4.8              | 1/2"      |
| SN-3223C | ●     | 0.58(14.8) | 119           | 1900        | 22.0(622.6)          | 90(6.3)      | 16-1/2"(419)   | 18.7       | 8.5  | 1/2"     | 113.3          | 4.8              | 1/2"      |
| SN-3214C | ●     | 0.68(17.2) | 142           | 1700        | 24.0(679.2)          | 90(6.3)      | 17-1/2"(445)   | 19.4       | 8.8  | 1/2"     | 114.1          | 6.2              | 1/2"      |
| SN-3224C | ●     | 0.58(14.8) | 142           | 1700        | 24.0(679.2)          | 90(6.3)      | 17-1/2"(445)   | 19.4       | 8.8  | 1/2"     | 114.1          | 6.2              | 1/2"      |



# AIR HAMMER



AIR HAMMER

## SN-1268 AIR NEEDLE SCALER



## SN-1288 AIR NEEDLE SCALER



## SN-1368 AIR NEEDLE SCALER



## SN-2124 AIR PISTOL GRIP NEEDLE SCALER



## SN-2128 AIR PISTOL GRIP NEEDLE SCALER



## SN-2110 AIR PISTOL GRIP NEEDLE SCALER



| Item No. | Needle Diameter | Numbers of Needle | Stroke Length | Blow Per Minute | Avg. Air Consumption | Air Pressure | Overall Length | Net Weight |      | Air Hose | Sound Pressure | Vibration Level  | Air Inlet |
|----------|-----------------|-------------------|---------------|-----------------|----------------------|--------------|----------------|------------|------|----------|----------------|------------------|-----------|
|          | mm              | inch(mm)          | mm            | b.p.m           | CFM (L/min)          | PSI (bar)    | inch(mm)       | LBS        | kg   | Inch     | dBA            | m/s <sup>2</sup> | Inch      |
| SN-1268  | 3x180           | 19                | 28            | 4600            | 15(424)              | 90(6.3)      | 18-1/8"(460)   | 6.2        | 2.80 | 3/8"     | 91.0           | 13.7             | 1/4"      |
| SN-1288  | 3x125           | 12                | 32            | 5500            | 3(85)                | 90(6.3)      | 11-3/8"(290)   | 2.9        | 1.30 | 3/8"     | 86.0           | 7.7              | 1/4"      |
| SN-1368  | 3x180           | 19                | 27            | 3400            | 16(453)              | 90(6.3)      | 17"(430)       | 5.9        | 2.70 | 3/8"     | 91.0           | 13.7             | 1/4"      |
| SN-2110  | 3x180           | 19                | 33            | 3700            | 15(424)              | 90(6.3)      | 13"(330)       | 6.1        | 2.80 | 3/8"     | 97.0           | 9.7              | 1/4"      |
| SN-2128  | 3x180           | 28                | 28            | 3500            | 7.4(198)             | 90(6.3)      | 13-9/16"(335)  | 6.2        | 2.80 | 3/8"     | 100.0          | 8.1              | 3/8"      |
| SN-2124  | 3x180           | 23                | 27            | 4000            | 7.4(209)             | 90(6.3)      | 13-9/16"(350)  | 7.9        | 3.60 | 3/8"     | 99.0           | 14.8             | 3/8"      |

# AIR HYDRAULIC RIVETER

| ITEM             | MATERIAL  |           | RIVET DIAMETER( ØMM) |       |     |       |     |     |     |  |
|------------------|-----------|-----------|----------------------|-------|-----|-------|-----|-----|-----|--|
|                  |           |           | (2.5)                | (3.0) | 4.0 | (5.0) | 6.4 | 7.2 | 8.0 |  |
| RIVET            | RIVET     | MANDREL   | 2.4                  | 3.2   |     | 4.8   |     |     |     |  |
| <b>PA-111</b>    | aluminum  | aluminum  |                      |       |     |       |     |     |     |  |
|                  | aluminum  | steel     |                      |       |     |       |     |     |     |  |
|                  | steel     | steel     |                      |       |     |       |     |     |     |  |
|                  | stainless | steel     |                      |       |     |       |     |     |     |  |
| <b>PA-201</b>    | stainless | stainless |                      |       |     |       |     |     |     |  |
|                  | aluminum  | aluminum  |                      |       |     |       |     |     |     |  |
|                  | aluminum  | steel     |                      |       |     |       |     |     |     |  |
|                  | steel     | steel     |                      |       |     |       |     |     |     |  |
| <b>PA-201V</b>   | stainless | steel     |                      |       |     |       |     |     |     |  |
|                  | stainless | steel     |                      |       |     |       |     |     |     |  |
|                  | aluminum  | aluminum  |                      |       |     |       |     |     |     |  |
|                  | aluminum  | steel     |                      |       |     |       |     |     |     |  |
| <b>PA-211</b>    | steel     | steel     |                      |       |     |       |     |     |     |  |
|                  | stainless | steel     |                      |       |     |       |     |     |     |  |
|                  | stainless | steel     |                      |       |     |       |     |     |     |  |
|                  | stainless | stainless |                      |       |     |       |     |     |     |  |
| <b>PA-211VMC</b> | aluminum  | aluminum  |                      |       |     |       |     |     |     |  |
|                  | aluminum  | steel     |                      |       |     |       |     |     |     |  |
|                  | steel     | steel     |                      |       |     |       |     |     |     |  |
|                  | stainless | steel     |                      |       |     |       |     |     |     |  |
| <b>PA-301</b>    | stainless | stainless |                      |       |     |       |     |     |     |  |
|                  | aluminum  | aluminum  |                      |       |     |       |     |     |     |  |
|                  | aluminum  | steel     |                      |       |     |       |     |     |     |  |
|                  | steel     | steel     |                      |       |     |       |     |     |     |  |
| <b>PA-301V</b>   | stainless | steel     |                      |       |     |       |     |     |     |  |
|                  | stainless | steel     |                      |       |     |       |     |     |     |  |
|                  | aluminum  | aluminum  |                      |       |     |       |     |     |     |  |
|                  | aluminum  | steel     |                      |       |     |       |     |     |     |  |
| <b>PA-301D</b>   | steel     | steel     |                      |       |     |       |     |     |     |  |
|                  | stainless | steel     |                      |       |     |       |     |     |     |  |
|                  | stainless | steel     |                      |       |     |       |     |     |     |  |
|                  | stainless | stainless |                      |       |     |       |     |     |     |  |
| <b>PA-321</b>    | aluminum  | aluminum  |                      |       |     |       |     |     |     |  |
|                  | aluminum  | steel     |                      |       |     |       |     |     |     |  |
|                  | steel     | steel     |                      |       |     |       |     |     |     |  |
|                  | stainless | steel     |                      |       |     |       |     |     |     |  |
| <b>PA-312V</b>   | stainless | stainless |                      |       |     |       |     |     |     |  |
|                  | aluminum  | aluminum  |                      |       |     |       |     |     |     |  |
|                  | aluminum  | steel     |                      |       |     |       |     |     |     |  |
|                  | steel     | steel     |                      |       |     |       |     |     |     |  |
| <b>PA-301VMC</b> | stainless | steel     |                      |       |     |       |     |     |     |  |
|                  | stainless | steel     |                      |       |     |       |     |     |     |  |
|                  | aluminum  | aluminum  |                      |       |     |       |     |     |     |  |
|                  | aluminum  | steel     |                      |       |     |       |     |     |     |  |
| <b>PA-211TS</b>  | steel     | steel     |                      |       |     |       |     |     |     |  |
|                  | stainless | steel     |                      |       |     |       |     |     |     |  |
|                  | stainless | steel     |                      |       |     |       |     |     |     |  |
|                  | stainless | stainless |                      |       |     |       |     |     |     |  |

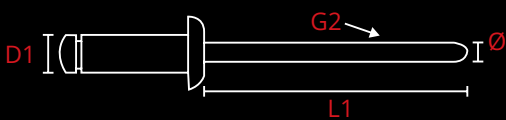

**Hydramlic cylinder  
Recommended Oil**

- SHELL Tellus NO.46
- ESSO Teresso NO.46
- MOBIL D.T.E 25 oil
- USM Spec NO.300B Oil
- CPC Circulation Oil R68

|                    | Rivet (D1) | Mandrel (L1) | Rivet Dia. (Ø) |
|--------------------|------------|--------------|----------------|
| <b>Blind Rivet</b> | 2.4mm      | above27mm    | 1.42-1.51(G2)  |
|                    | 3.2mm      | above28mm    | 1.83-1.92(G2)  |
|                    | 4.0mm      | above29mm    | 2.28-2.42(G2)  |
|                    | 4.8mm      | above30mm    | 2.64-2.91(G2)  |
|                    | 6.4mm      | above30mm    | 3.84-4.15(G2)  |
| <b>PA-211TS</b>    | 6.4mm      | above40mm    | 3.84-4.15(G2)  |
|                    | 8.0mm      | above40mm    | 4.35-4.65(G2)  |

# AIR HYDRAULIC RIVETER

## PA-MC

### AUTOMATIC MANDREL COLLECTION

#### CONTENTS

- 3/32"(2.4mm) 220pcs
- 1/8" (3.2mm) 160pcs
- 5/32"(4.0mm) 110pcs
- 3/16"(4.8mm) 80pcs



## PE-MC

### AUTOMATIC MANDREL COLLECTION



## PA-111



3 pieces in one carton



## PA-201



6 pieces in one carton



## PA-201V

Vaccum type



6 pieces in one carton



## PA-211



6 pieces in one carton



## PA-321



6 pieces in one carton



## PA-312V

Vaccum type



6 pieces in one carton



## PA-301V

Vaccum type



6 pieces in one carton



## PA-301



10 pieces in one carton



## PA-301D



2 pieces in one carton



## PA-301L



## PA-203N



6 pieces in one carton



| Item No. | Traction Power | Stroke Length | Capacity | Avg. Air Consumption | Air Pressure | Net Weight |      | Air Hose | Sound Pressure | Vibration Level  | Air Inlet |
|----------|----------------|---------------|----------|----------------------|--------------|------------|------|----------|----------------|------------------|-----------|
|          | lb.-f(kg.-f)   | mm            | mm       | L/cycle              | PSI (bar)    | LBS        | kg   | Inch     | dBA            | m/s <sup>2</sup> | Inch      |
|          |                |               |          |                      |              |            |      |          |                |                  |           |
| PA-111   | 4100(1860)     | 26            | 4.8-6.4  | 2.88                 | 90(6.3)      | 6.6        | 3.00 | 3/8"     | 82.0           | 0.8              | 1/4"      |
| PA-201   | 3534(1603)     | 14            | 2.4-6.4  | 2.32                 | 90(6.3)      | 3.9        | 1.80 | 3/8"     | 79.7           | 0.5              | 1/4"      |
| PA-201V  | 3534(1603)     | 14            | 2.4-6.4  | 2.32                 | 90(6.3)      | 3.9        | 1.80 | 3/8"     | 79.7           | 0.5              | 1/4"      |
| PA-211   | 3748(1700)     | 18            | 2.4-6.4  | 2.9                  | 90(6.3)      | 3.8        | 1.75 | 3/8"     | 79.7           | 0.8              | 1/4"      |
| PA-321   | 2612(1185)     | 22            | 2.4-4.8  | 1.48                 | 90(6.3)      | 3.3        | 1.50 | 3/8"     | 79.7           | 0.4              | 1/4"      |
| PA-312V  | 1983(900)      | 18            | 2.4-4.8  | 1.8                  | 90(6.3)      | 3.8        | 1.74 | 3/8"     | 75.3           | 0.4              | 1/4"      |
| PA-301V  | 2303(1045)     | 16            | 2.4-4.8  | 1.48                 | 90(6.3)      | 3.3        | 1.50 | 3/8"     | 79.7           | 0.3              | 1/4"      |
| PA-301   | 2303(1045)     | 16            | 2.4-4.8  | 1.48                 | 90(6.3)      | 3.3        | 1.50 | 3/8"     | 79.7           | 0.3              | 1/4"      |
| PA-301D  | 2303(1045)     | 16            | 2.4-4.8  | 1.48                 | 90(6.3)      | 3.3        | 1.50 | 3/8"     | 79.7           | 0.3              | 1/4"      |
| PA-301L  | 2303(1045)     | 16            | 2.4-4.8  | 1.48                 | 90(6.3)      | 3.3        | 1.50 | 3/8"     | 79.7           | 0.3              | 1/4"      |
| PA-203   | 2640(1200)     | 16            | 3.2-6.4  | 1.48                 | 90(6.3)      | 3.3        | 1.50 | 3/8"     | 79.7           | 0.5              | 1/4"      |

### PB-2601 AIR HYDRAULIC NUT SETTER



5 pieces in one carton



### PA-211TS AIR HYDRAULIC RIVETER



6 pieces in one carton



### PB-2402 AIR HYDRAULIC RIVET NUT TOOL



6 pieces in one carton



### PB-1305/PB-1308/PB-1310 AIR RIVET NUT TOOL



12 pieces in one carton



### PB-1312 AIR RIVET NUT TOOL



12 pieces in one carton



| Item No. | Traction Power | Free Speed | Stroke Length | Capacity                        | Avg. Air Consumption | Air Pressure | Net Weight |      | Air Hose | Sound Pressure | Vibration Level  | Air Inlet |
|----------|----------------|------------|---------------|---------------------------------|----------------------|--------------|------------|------|----------|----------------|------------------|-----------|
|          | lb.-f(kg.-f)   | R.P.M      | mm            | mm                              | L/cycle              | PSI (bar)    | LBS        | kg   | Inch     | dBA            | m/s <sup>2</sup> | Inch      |
|          |                |            |               |                                 |                      |              |            |      |          |                |                  |           |
| PB-2601  | 4300(594.5)    | 3500       | 0-7.0         | M3-M12                          | 7.5                  | 90(6.3)      | 5.4        | 2.46 | 3/8"     | 80             | 1.2              | 1/4"      |
| PA-211TS | 3748(1700)     | ---        | 18            | 6.4&8.0                         | 2.90                 | 90(6.3)      | 3.80       | 1.75 | 3/8"     | 79.7           | 0.8              | 1/4"      |
| PB-2402  | 3638(1650)     | ---        | 9             | Steel M4.M10<br>Stainless M4.M8 | 1.50                 | 90(6.3)      | 3.40       | 1.55 | 3/8"     | 82.0           | 0.8              | 1/4"      |
| PB-1305  | ---            | 1200       | ---           | M3.M4.M5                        | 7.8                  | 90(6.3)      | 2.42       | 1.10 | 3/8"     | 86.0           | 1.6              | 1/4"      |
| PB-1308  | ---            | 600        | ---           | M6.M8                           | 7.8                  | 90(6.3)      | 2.86       | 1.30 | 3/8"     | 86.0           | 1.6              | 1/4"      |
| PB-1310  | ---            | 400        | ---           | M8.M10                          | 7.8                  | 90(6.3)      | 2.80       | 1.30 | 3/8"     | 86.0           | 1.6              | 1/4"      |
| PB-1312  | ---            | 400        | ---           | M10.M12                         | 7.8                  | 90(6.3)      | 2.80       | 1.27 | 3/8"     | 86.0           | 1.6              | 1/4"      |

# RIVETER ADAPTOR RIVET NUT ADAPTOR

RIVETER ADAPTOR / RIVET NUT ADAPTOR

**PB-9006**  
M6 RIVET NUT ADAPTOR

**PA-9048**  
4.8mm (3/16") RIVET ADAPTOR

**PB-9010**  
M10 RIVET NUT ADAPTOR

**PA-9064**  
6.35mm (1/4") RIVET ADAPTOR



**PA-9048PT**  
RIVETER ADAPTOR

**PA-48PB06T**  
RIVETER ADAPTOR + RIVET NUT ADAPTOR

**PB-9006PT**  
RIVET NUT ADAPTOR



**PB-9006P**  
M6 RIVET NUT ADAPTOR

**PA-9048P**  
4.8mm (3/16") RIVET ADAPTOR

**PB-9010P**  
M10 RIVET NUT ADAPTOR

**PA-9064P**  
6.35mm (1/4") RIVET ADAPTOR



## Assembling And Using Before First Use

Remove the unit and the accessory out of the packaging. Keep packaging materials out of reach of children. There is risk of suffocation.



## TECHNICAL DATA

### PA-9064

|                      |                                   |
|----------------------|-----------------------------------|
| Dimensions           | 59mm x 173mm( 2-11/16" x 6-3/4" ) |
| Net Weight           | 330g=0.73 lbs                     |
| Gross Weight         | 500g=1.10 lbs                     |
| Nosepiece            | 3.2mm(1/8"), 4.0mm(5/32")         |
| Nosepiece            | 4.8mm(3/16"), 6.4mm(1/4")         |
| Hex Shank            | 1/4"(6.35mm)                      |
| Cordless Drill       | 14.4V, 18V                        |
| Cordless Drive       | 14.4V, 18V                        |
| Reversible electric  | 1/2"Drill                         |
| Reversible pneumatic | 1/2"Drill                         |
| Min. Torque Strength | 50 Nm = 37 ft/lbs                 |
| Max. rpm             | 1000 rpm                          |

|                 |                            |
|-----------------|----------------------------|
| 1. Hex Shank    | 1/4" (6.35mm)              |
| 2. Housing      | PA+GF                      |
| 3. Nosepiece    | 3.2mm, 4.0mm, 4.8mm, 6.4mm |
| 4. Sight Window | Blind Rivet Loading        |
| 5. Wrench       | 1PC                        |
| 6. Handle       | 1PC                        |

### PB-9006

|                      |                                     |
|----------------------|-------------------------------------|
| Dimensions           | 59mm x 172mm( 2-11/32" x 6-25/32" ) |
| Net Weight           | 280g=0.62 lbs                       |
| Nosepiece            | M3.M4.M5.M6                         |
| Hex Shank            | 1/4"(6.35mm)                        |
| Cordless Drill       | 12V, 14.4V                          |
| Cordless Drive       | 12V, 14.4V                          |
| Reversible electric  | Drill(Advice 500W)                  |
| Reversible pneumatic | Drill(Advice 3/8")                  |
| Min. Torque Strength | 15 Nm = 11 ft/lbs                   |
| Max. rpm             | 1000 rpm                            |

### PA-9048

|                      |                                   |
|----------------------|-----------------------------------|
| Dimensions           | 59mm x 158mm( 2-11/32" x 6-1/4" ) |
| Net Weight           | 318g=0.70 lbs                     |
| Gross Weight         | 368g=0.81 lbs                     |
| Nosepiece            | 2.4mm(3/32"), 3.2mm(1/8")         |
| Nosepiece            | 4.0mm(5/32"), 4.8mm(3/16")        |
| Hex Shank            | 1/4"(6.35mm)                      |
| Cordless Drill       | 12V, 14.4V, 18V                   |
| Cordless Drive       | 12V, 14.4V, 18V                   |
| Reversible electric  | 3/8"Drill                         |
| Reversible pneumatic | 3/8"Drill                         |
| Min. Torque Strength | 11 Nm = 8 ft/lbs                  |
| Max. rpm             | 1000 rpm                          |

|                 |                            |
|-----------------|----------------------------|
| 1. Hex Shank    | 1/4" (6.35mm)              |
| 2. Housing      | PA+GF                      |
| 3. Nosepiece    | 2.4mm, 3.2mm, 4.0mm, 4.8mm |
| 4. Sight Window | Blind Rivet Loading        |
| 5. Wrench       | 1PC                        |

### PB-9010

|                      |                                    |
|----------------------|------------------------------------|
| Dimensions           | 59mm x 180mm( 2-11/32" x 7-3/32" ) |
| Net Weight           | 350g=0.77 lbs                      |
| Nosepiece            | M6.M8.M10                          |
| Hex Shank            | 1/4"(6.35mm)                       |
| Cordless Drill       | 14.4V                              |
| Cordless Drive       | 18V                                |
| Reversible electric  | Drill(Advice 500W)                 |
| Reversible pneumatic | Drill(Advice 1/2")                 |
| Min. Torque Strength | 100 Nm = 73.7 ft/lbs               |
| Max. rpm             | 800 rpm                            |

# AIR NAILER & AIR STAPLER

## SJ-FN90E AIR FRAMING NAILER 34°



2 pieces in one carton

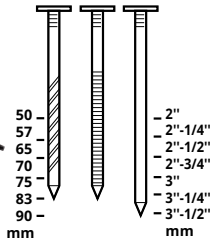

## SJ-1650T AIR NAILER SAFETY TRIGGER



5 pieces in one carton

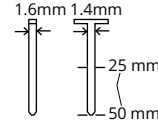

| Item No. | Collated   | Nail Head    | Nail Length      |     | Shank Dia |        | Load Capacity | Working Pressure | Weight | Air Inlet |
|----------|------------|--------------|------------------|-----|-----------|--------|---------------|------------------|--------|-----------|
|          |            |              | mm(inch)         | mm  | mm        | mm     |               |                  |        |           |
| SJ-FN90E | Paper/Wire | Clipped Head | 50-90(2"-3-1/2") | 2.9 | 3.3       | 75-105 | 90            | 3.9              | 1/4"   |           |

## SJ-1830F SJ-C1830F AIR NAILER SAFETY TRIGGER



10 pieces in one carton

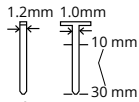

## SJ-1850F AIR NAILER SAFETY TRIGGER



10 pieces in one carton

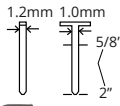

## SJ-TN64 AIR CONCRETE NAILER



4 pieces in one carton

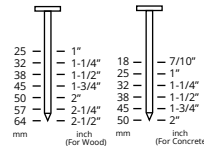

## SJ-BNF1664 AIR BRAD NAILER



10 pieces in one carton

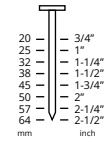

## SU-C422J SU-C1022J AIR NAILER



10 pieces in one carton

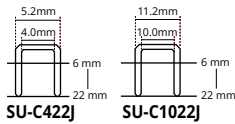

## SU-8016 AIR STAPLER SAFETY TRIGGER



10 pieces in one carton

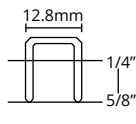

## SU-9025 AIR STAPLER SAFETY TRIGGER



10 pieces in one carton

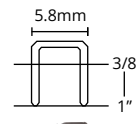

## SU-9040 AIR STAPLER SAFETY TRIGGER



4 pieces in one carton

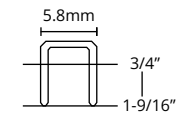
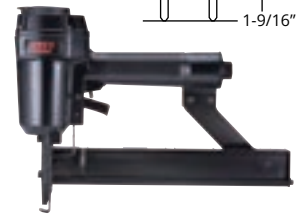

| Item No.   | Head Dia. | Gauge | Nail Length         |      | Crown     |     | Shank (Thickness/Width) |       | Load Capacity | Working Pressure | Weight | Air Inlet |
|------------|-----------|-------|---------------------|------|-----------|-----|-------------------------|-------|---------------|------------------|--------|-----------|
|            | mm        |       | mm(inch)            | mm   | mm        | mm  | mm                      | Nails |               |                  |        |           |
| SJ-1650T   | 2.8       | 16    | 20-50(3/4"-2")      | ---  | ---       | 1.4 | 1.60                    | 100   | 90            | 2.35             | 1/4"   |           |
| SJ-1830F   | 1.9       | 18    | 10-30(3/8"-1-2/11") | ---  | ---       | 1.0 | 1.2                     | 100   | 90            | 1.2              | 1/4"   |           |
| SJ-1850F   | ---       | 18    | 20-50(3/4"-2")      | ---  | ---       | 1.0 | 1.2                     | 100   | 90            | 1.4              | 1/4"   |           |
| SJ-TN64    | 7.5       | 13    | (18-64)             | ---  | ---       | 2.5 | 2.50                    | 80    | 90            | 2.35             | 1/4"   |           |
| SJ-BNF1664 | 2.8       | 16    | (20-64)             | ---  | ---       | 1.4 | 1.60                    | 100   | 90            | 2.35             | 1/4"   |           |
| SU-C422J   | ---       | 20    | 6-22(1/4"-7/8")     | 4    | 0.6x1.2   | --- | ---                     | 100   | 90            | 1.15             | 1/4"   |           |
| SU-C1022J  | 1.9       | 20    | 6-22(1/4"-7/8")     | 10   | 0.6x1.2   | --- | ---                     | 100   | 90            | 1.20             | 1/4"   |           |
| SU-8016    | ---       | 21    | 6-16(1/4"-5/8")     | 12.8 | 0.65x0.95 | --- | ---                     | 100   | 90            | 0.90             | 1/4"   |           |
| SU-9025    | ---       | 18    | 10-25(3/8"-1")      | 5.8  | 1.0x1.25  | --- | ---                     | 100   | 90            | 1.1              | 1/4"   |           |
| SU-9040    | ---       | 18    | 10-40(3/4"-1-9/16") | 5.8  | 1.2x1.25  | --- | ---                     | 100   | 90            | 2.20             | 1/4"   |           |

AIR NAILER & AIR STAPLER

# AIR NAILER & AIR STAPLER

AIR NAILER & AIR STAPLER

## SU-H3518S SU-H3522S SU-H3218S SU-H3222S

**HAND CARTON STAPLER**

★★ 5 pieces in one carton

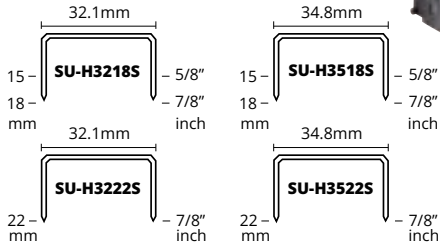

## SU-A3518S SU-A3522S SU-A3218S SU-A3222S

**AIR CARTON STAPLER**

★★ 5 pieces in one carton

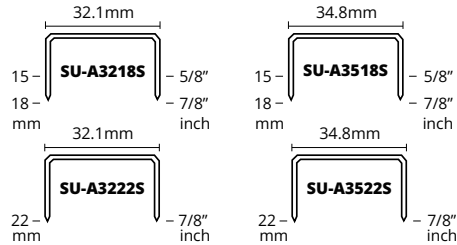

| Item No.  | Dimensions  | Nail Length | Crown | Shank (Thickness/Width) |     | Load Capacity | Working Pressure | Weight |
|-----------|-------------|-------------|-------|-------------------------|-----|---------------|------------------|--------|
|           | mm          |             |       | mm                      | mm  |               |                  |        |
| SU-A3518S | 200x102x400 | 15 & 18     | 34.8  | 0.9                     | 2.2 | 100           | 90               | 2.53   |
| SU-A3522S | 200x102x400 | 22          | 34.8  | 0.9                     | 2.2 | 100           | 90               | 2.53   |
| SU-A3218S | 200x102x400 | 15 & 18     | 32.1  | 0.9                     | 1.9 | 100           | 90               | 2.53   |
| SU-A3222S | 200x102x400 | 22          | 32.1  | 0.9                     | 1.9 | 80            | 90               | 2.53   |
| SU-H3518S | 310x102x460 | 15 & 18     | 34.8  | 0.9                     | 2.2 | 100           | ---              | 2.18   |
| SU-H3522S | 310x102x460 | 22          | 34.8  | 0.9                     | 2.2 | 100           | ---              | 2.18   |
| SU-H3218S | 310x102x460 | 15 & 18     | 32.1  | 0.9                     | 1.9 | 100           | ---              | 2.18   |
| SU-H3222S | 310x102x460 | 22          | 32.1  | 0.9                     | 1.9 | 100           | ---              | 2.18   |

## SJ-CN55

**COIL NAILER SAFETY TRIGGER**

★★ 4 pieces in one carton

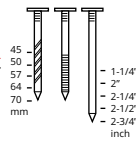

## SJ-CN57

**57mm AIR COIL NAILER SAFETY TRIGGER**

★★ 4 pieces in one carton

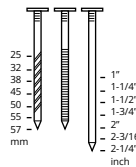

## SJ-CN65

**65mm AIR COIL NAILER SAFETY TRIGGER**

★★ 4 pieces in one carton

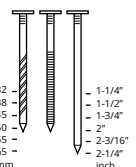

## SJ-CN70

**COIL NAILER SAFETY TRIGGER**

★★ 4 pieces in one carton

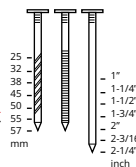

## SJ-CN90

**AIR COIL NAILER**

★★ 4 pieces in one carton



| Item No. | Shank Dia. | Head Dia. | Nail Length | Collated           | Driving Power | Load Capacity | Dimensions  | Working Pressure | Weight | Air Inlet |
|----------|------------|-----------|-------------|--------------------|---------------|---------------|-------------|------------------|--------|-----------|
|          | mm         | mm        |             |                    |               |               | (HxWxL)mm   |                  |        |           |
| SJ-CN55  | 2.1-2.3    | 5.0-5.7   | 25-57       | Wire               | 36.54         | 300-350       | 283x131x270 | 90               | 2.8    | 1/4"      |
| SJ-CN57  | 2.1-2.3    | 5.0-6.0   | 25-57       | Wire/Plastic Sheet | 36.40         | 200-300       | 310x130x300 | 90               | 2.2    | 1/4"      |
| SJ-CN65  | 2.3-2.5    | 5.0-6.0   | 32-65       | Wire/Plastic Sheet | 39.70         | 200-300       | 330x130x300 | 90               | 2.3    | 1/4"      |
| SJ-CN70  | 2.3-2.9    | 5.7-7.0   | 45-70       | Wire               | 61.07         | 150-300       | 303x129x307 | 90               | 3.7    | 1/4"      |
| SJ-CN90  | 2.5-3.3    | 6.0-7.2   | 50-90       | Wire               | 79.43         | 150-300       | 375x125x340 | 90               | 3.7    | 1/4"      |

# AIR GREASE GUN

## SG-400C COMPOSITE AIR GREASE GUN

10 pieces in one carton



## SG-400/SG-500 AIR GREASE GUN

10 pieces in one carton



## SG-401/SG-501 AIR GREASE GUN

Continuous type  
10 pieces in one carton



## SG-405 AIR GREASE GUN

10 pieces in one carton



## SG-902 GREASE TUBE ADAPTER



## SG-407 AIR GREASE GUN

Continuous type  
10 pieces in one carton

- SG-401 + SG-902 400ml
- Key Spec :
- Single shot type
- 19.6mm & 33.6mm
- Thread Adapter Included

## SG-911 360° SWIVEL GREASE COUPLER

• 1/8 x 27 Thread



## SG-910 90° GREASE COUPLER

• 1/8 x 27 Thread



## SG-910S 90° GREASE COUPLER

• 1/8 x 27 Thread



## SG-912 QUICK RELEASE GREASE COUPLER

• 1/8 x 27 Thread



## SG-912L QUICK RELEASE GREASE COUPLER

• 1/8 x 27 Thread



| Item No. | Working Pressure    | Proof Pressure      | Capacity | Net Weight |      | Air Hose | Sound Pressure | Vibration Level  | Air Inlet |
|----------|---------------------|---------------------|----------|------------|------|----------|----------------|------------------|-----------|
|          | kgf/cm <sup>2</sup> | kgf/cm <sup>2</sup> | C.C      | LBS        | kg   | Inch     | dB(A)          | m/s <sup>2</sup> | Inch      |
| SG-400   | 2.8-8.4             | 10.5                | 400      | 3.2        | 1.46 | 3/8"     | 80.2           | 0.7              | 1/4"      |
| SG-500   | 2.8-8.4             | 10.5                | 500      | 3.52       | 1.6  | 3/8"     | 80.2           | 0.7              | 1/4"      |
| SG-400C  | 2.8-8.4             | 10.5                | 400      | 2.2        | 1.0  | 3/8"     | 81.4           | 0.6              | 1/4"      |
| SG-401   | 2.8-8.4             | 10.5                | 400      | 3.52       | 1.6  | 3/8"     | 74.0           | 2.0              | 1/4"      |
| SG-501   | 2.8-8.4             | 10.5                | 500      | 3.74       | 1.7  | 3/8"     | 74.0           | 2.0              | 1/4"      |



# AIR BLOW GUN

## JC-202

**AIR BLOW GUN**

60 pieces in one carton



Extendable tube.  
Revolvable nozzle.

## JC-602

**HIGH VOLUME AIR BLOW GUN**

20 pieces in one carton



## JC-491

**STANDARD SAFETY TIP**



- Available with JC-491 for JC-405, JC-410, JC-412, JC-424, JC-435

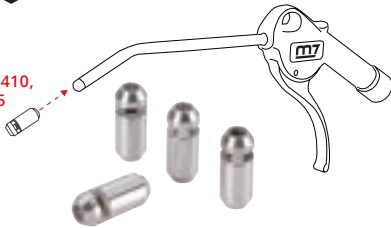

## JC-405/JC-410/JC412 JC-424/JC-435

**AIR BLOW GUN**



100 pieces in one carton

JC-405

50 pieces in one carton

JC-410/JC412/JC-424/JC-435



lathing (safe tenon)

## JC-640/JC-641/JC-680

**SUPER AIR BLOW GUN**

30 pieces in one carton

- JC-640 / JC-641 40"
- JC-680 80"

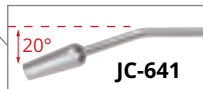

## JC-0424[SET]

**AIR BLOW GUN**

4 set in one carton

- Contents
- JC-405 8PCS
- JC-410 8PCS
- JC-412 8PCS



## JC-0415[SET]

**AIR BLOW GUN**

4 set in one carton

- Contents
- JC-405 15PCS



| Item No. | Nozzle Length | Working Pressure | Max Pressure | Avg. Air Consumption | Avg. Air Consumption | Net Weight |      | Air Hose | Sound Pressure | Air Inlet |
|----------|---------------|------------------|--------------|----------------------|----------------------|------------|------|----------|----------------|-----------|
|          | inch          | PSI(bar)         | PSI(bar)     | CFM(L/min)           | CFM(L/min)           | LBS        | kg   | Inch     | dBA            | Inch      |
| JC-202   | 7"-12"        | 90-120(6.2-8.5)  | 220(15.1)    | ---                  | 5.10(144)            | 0.38       | 0.17 | 3/8"     | 90.0           | 1/4"      |
| JC-405   | 5"            | 75-120(5.3-8.5)  | 150(10.6)    | 13.0(368)            | 15.0(425)            | 0.24       | 0.11 | 3/8"     | 90.0           | 1/4"      |
| JC-410   | 10"           | 75-120(5.3-8.5)  | 150(10.6)    | 13.0(368)            | 15.0(425)            | 0.26       | 0.12 | 3/8"     | 90.0           | 1/4"      |
| JC-412   | 12"           | 75-120(5.3-8.5)  | 150(10.6)    | 13.0(368)            | 15.0(425)            | 0.28       | 0.13 | 3/8"     | 90.0           | 1/4"      |
| JC-424   | 24"           | 75-120(5.3-8.5)  | 150(10.6)    | 13.0(368)            | 15.0(425)            | 0.31       | 0.14 | 3/8"     | 90.0           | 1/4"      |
| JC-435   | 35"           | 75-120(5.3-8.5)  | 150(10.6)    | 13.0(368)            | 15.0(425)            | 0.55       | 0.25 | 3/8"     | 90.0           | 1/4"      |
| JC-602   | 2"            | 90-120           | 230          | 13.0(368)            | 15.0(425)            | 1.32       | 0.6  | 3/8"     | 90.0           | 1/4"      |
| JC-640   | 40"           | 75-120(5.3-8.5)  | 150(10.6)    | 13.0(368)            | 15.0(425)            | 0.75       | 0.34 | 3/8"     | 90.0           | 1/4"      |
| JC-641   | 40"           | 75-120(5.3-8.5)  | 150(10.6)    | 13.0(368)            | 15.0(425)            | 0.75       | 0.34 | 3/8"     | 90.0           | 1/4"      |
| JC-680   | 80"           | 75-120(5.3-8.5)  | 150(10.6)    | 13.0(368)            | 15.0(425)            | 1.41       | 0.64 | 3/8"     | 90.0           | 1/4"      |

# AUTO REPAIR TOOL

## NC-0208[SET]

1/4" DRIVE Twin dog type



10 pieces in one carton

Contents 8 pcs

- 1pc - 1/4" Air Impact Wrench (NC-2710)
- 5pcs - Impact sockets : 8, 9, 10, 11, 12 mm
- 1pc - 1/4" Drive Universal Joint
- 1pc - 1/4" Extension Bar
- 1pc - 1/4" plug



NC-2710



## NC-2210[SET]

1/4" DRIVE Twin dog type



1 carton / 5 set 20 pieces in one carton

Contents 10 pcs

- 1pc - 1/4" Air Impact Wrench (NC-2210)
- 5pcs - Impact sockets : 8, 9, 10, 11, 12 mm
- 1pc - 1/4" Drive Universal Joint
- 2pcs - 1/4" Extension Bar (L : 50, 125mm)
- 1pc - 1/4" plug



NC-2210



| Item No. | Square Drive |           | Bolt Capacity   | Torque Range |          | Max Torque |             | Free Speed    | Avg. Air Consumption | Air Pressure | Overall Length |     | Net Weight       |      | Air Hose | Sound Pressure | Vibration Level | Air Inlet |
|----------|--------------|-----------|-----------------|--------------|----------|------------|-------------|---------------|----------------------|--------------|----------------|-----|------------------|------|----------|----------------|-----------------|-----------|
|          | Inch         | Inch (mm) |                 | FT-LB (Nm)   | FT-LB Nm | R.P.M      | CFM (L/min) | PSI (bar)     | Inch (mm)            | LBS kg       | Inch           | dBA | m/s <sup>2</sup> | Inch |          |                |                 |           |
| NC-2710  | 1/4"         | M8        | 7.4-29.5(10-40) | 29 40        | 11000    | 5.3(150)   | 90(6.3)     | 5-3/8"(136)   | 1.76 0.8             | 3/8"         | 91.0           | 3.4 | 1/4"             |      |          |                |                 |           |
| NC-2210  | 1/4"         | M5        | 4-45(6-61)      | 50 67.8      | 11000    | 1.8(51)    | 90(6.3)     | 6-17/32"(166) | 1.69 0.77            | 3/8"         | 77.0           | 1.8 | 1/4"             |      |          |                |                 |           |

## QA-651N[SET]

AIR DIE GRINDER



1 carton / 5 set 20 pieces in one carton

Contents 16 pcs

- 1pc - Air Die Grinder (QA-651)
- 1pc - Collet : 3mm (or 1/8")
- 5pcs - Grinder Stones 3mm
- 5pcs - Grinder Stones 6mm
- 2pcs - Spanner Wrench
- 1pc - 1/4" plug
- 1pc - Oil Box



QA-651



| Item No. | Collet Size | Free Speed | Avg. Air Consumption | Air Pressure | Overall Length | Motor | Net Weight |      | Air Hose | Sound Pressure   | Vibration Level | Air Inlet |
|----------|-------------|------------|----------------------|--------------|----------------|-------|------------|------|----------|------------------|-----------------|-----------|
|          | inch(mm)    | R.P.M      | CFM (L/min)          | PSI (bar)    | Inch (mm)      | HP    | LBS kg     | Inch | dBA      | m/s <sup>2</sup> | Inch            |           |
| QA-651   | 1/4"(6)     | 18000      | 2.7(76)              | 90(6.3)      | 5"(127)        | 0.3   | 1.10 0.5   | 3/8" | 74.0     | 0.3              | 1/4"            |           |

## QB-0618[SET]

90° MINI SANDER 18 PCS SET



10 pieces in one carton

Contents 18 pcs

- 1pc - QB-625
- 1pc - Disc 2" PAD
- 1pc - Disc 3" PAD
- Removal Sandering
- 1pc - 2" #80-YL
- 2pcs - 2" #150-RD
- 2pcs - 2" #300-BL
- 1pc - 2" Stripping Disc
- 1pc - 3" #80-YL
- 2pcs - 3" #150-RD
- 2pcs - 3" #300-BL
- 1pc - 3" Stripping Disc
- 1pc - Adaptor
- 1pc - Spanner
- 1pc - Oil



QB-625



| Item No. | Pad Dia / Arbor Size | Free Speed | Avg. Air Consumption | Air Pressure | Overall Length | Motor | Net Weight |      | Air Hose | Sound Pressure   | Vibration Level | Air Inlet |
|----------|----------------------|------------|----------------------|--------------|----------------|-------|------------|------|----------|------------------|-----------------|-----------|
|          | inch                 | R.P.M      | CFM                  | PSI (bar)    | Inch (mm)      | HP    | LBS kg     | Inch | dBA      | m/s <sup>2</sup> | Inch            |           |
| QB-625   | 2" / 3"              | 15000      | 17.2                 | 90(6.3)      | 7-1/8"(180)    | 0.6   | 1.3 0.61   | 3/8" | 75       | 2.5              | 1/4"            |           |

AUTO REPAIR TOOL

# AUTO REPAIR TOOL

## QE-323N[SET]

**1/4" AIR REVERSIBLE DRILL**



1 carton / 5 set 20 pieces in one carton

**Contents 9 pcs**

- 1pc - 3.5mm Drill Bits
- 1pc - 4.0mm Drill Bits
- 1pc - 4.5mm Drill Bits
- 1pc - 5.0mm Drill Bits
- 1pc - 5.5mm Drill Bits
- 1pc - Key Wrench
- 1pc - 1/4" Plug
- 1pc - Oil Box
- 1pc - Air Reversible Drill(QE-323)



QE-323



| Item No. | Chuck Size | Free Speed | Motor | Overall Length | Avg. Air Consumption | Air Pressure | Net Weight |      | Air Hose | Sound Pressure | Vibration Level  | Air Inlet |
|----------|------------|------------|-------|----------------|----------------------|--------------|------------|------|----------|----------------|------------------|-----------|
|          | inch(mm)   | R.P.M      | HP    | inch(mm)       | CFM (L/min)          | PSI (bar)    | LBS        | kg   | Inch     | dBA            | m/s <sup>2</sup> | Inch      |
| QE-323   | 1/4"(6.35) | 1600       | 0.38  | 6-15/32"(164)  | 1.9(54)              | 90(6.3)      | 1.7        | 0.78 | 3/8"     | 74.0           | 1.2              | 1/4"      |

## QP-212N[SET]

**AIR HIGH SPEED SANDER**



1 carton / 5 set 20 pieces in one carton

**Contents 12 pcs**

- 1pc - Air High Speed Sander
- 1pc - 2" Rubber PAD(1/4"-20)
- 1pc - 2" Pad Die#80
- 1pc - 2" Stripping Disc #80-YL(Coarse)
- 1pc - 2" Stripping Disc #150-RD(Med)
- 1pc - 2" Rubber PAD(1/4"-20)
- 1pc - 3" Pad Die#80
- 1pc - 3" Stripping Disc #80-YL(Coarse)
- 1pc - 3" Stripping Disc #150-RD(Med)
- 1pc - 1/4" Plug
- 1pc - Oil Box
- 1pc - Spanner Wrench



QE-212



## QP-213N[SET]

**AIR ORBIT SANDER**



1 carton / 5 set 20 pieces in one carton

**Contents 67 pcs**

- 1pc - Air Sander
- 1pc - 2" PAD(5/16"-24)
- 1pc - 3" PAD(5/16"-24)
- 10pcs - 2" Sandpaper#180
- 10pcs - 2" Sandpaper#220
- 10pcs - 2" Sandpaper#320
- 1pc - 1/4" Plug
- 1pc - Oil Box
- 2pcs - Spanner Wrench
- 10pcs - 3" Sandpaper#180
- 10pcs - 3" Sandpaper#220
- 10pcs - 3" Sandpaper#320



QE-212



## QP-223N[SET]

**AIR MINI POLISHER**



1 carton / 5 set 20 pieces in one carton

**Contents 7 pcs**

- 1pc - Air Mini Polisher(QP-223)
- 1pc - 3"PAD(5/16"-24)
- 1pc - 3"Sponge (Medium)
- 1pc - 3"Sponge (Rough)
- 1pc - 3"Wool Bonnet
- 1pc - 1/4" Plug
- 1pc - Spanner Wrench



QE-223



## QP-415

**AIR ANGLE POLISHER**



10 pieces in one carton



*Stylized grip*

| Item No. | Pad Dia  | Spindle Size | Free Speed | Avg. Air Consumption | Air Pressure | Overall Length | Motor | Net Weight |      | Air Hose | Sound Pressure | Vibration Level  | Air Inlet |
|----------|----------|--------------|------------|----------------------|--------------|----------------|-------|------------|------|----------|----------------|------------------|-----------|
|          | inch(mm) |              | R.P.M      | CFM (L/min)          | PSI (bar)    | Inch (mm)      | HP    | LBS        | kg   | Inch     | dBA            | m/s <sup>2</sup> | Inch      |
| QP-212   | 2" or 3" | 1/4"-20      | 18000      | 2.1(59)              | 90(6.3)      | 4-1/4"(107)    | 0.3   | 1.1        | 0.50 | 3/8"     | 73.0           | 0.9              | 1/4"      |
| QP-213   | 3"(76)   | 5/16"-24     | 18000      | 2.1(59)              | 90(6.3)      | 4-5/8"(117)    | 0.3   | 1.1        | 0.50 | 3/8"     | 76.0           | 1.2              | 1/4"      |
| QP-223   | 3"(76)   | 5/16"-24     | 5500       | 2.2(62)              | 90(6.3)      | 5-1/8"(130)    | 0.38  | 1.3        | 0.6  | 3/8"     | 74.0           | 0.9              | 1/4"      |
| QP-415   | 5"(127)  | 5/16"-24     | 2500       | 5.0(141)             | 90(6.3)      | 8-11/32"(211)  | 0.5   | 2.5        | 1.14 | 3/8"     | 85.0           | 1.1              | 1/4"      |

# RA-505N[SET]

## AIR SCREWDRIVER

Twin dog type Screw capacity : M5



1 carton / 5 set 20 pieces in one carton

### Contents 8 pcs

- 1pc Air Screwdriver
- 2pcs Bits FD(L:50mm)
- 2pcs Bits PH2(L:65mm)
- 1pcs Bits PH2(L:100mm)
- 1pc 1/4"Plug
- 1pc Oil Box



RA-505



| Item No. | Bit Size   | Torque Range | Free Speed | Overall Length | Avg. Air Consumption | Air Pressure | Net Weight |     | Air Hose | Sound Pressure | Vibration Level  | Air Inlet |
|----------|------------|--------------|------------|----------------|----------------------|--------------|------------|-----|----------|----------------|------------------|-----------|
|          | inch(mm)   | FT-LB(Nm)    | R.P.M      | inch(mm)       | CFM (L/min)          | PSI (bar)    | LBS        | kg  | Inch     | dBA            | m/s <sup>2</sup> | Inch      |
| RA-505   | 1/4"(6.35) | 5-45(6-61)   | 11000      | 6-5/16"(161)   | 1.8(51)              | 90(6.3)      | 1.54       | 0.7 | 3/8"     | 74.0           | 3.3              | 1/4"      |

# QT-102

## AIR TYRE BUFFER



20 pieces in one carton



# QT-103

## AIR TYRE BUFFER



20 pieces in one carton



# QT-203/QT-113

## AIR TYRE BUFFER/QUICK CHANGE CHUCK



20 pieces in one carton



# QT-112T

## AIR TYRE BUFFER



10 pieces in one carton

2pcs Planet Gear with bearing

Stylized grip



# QT-203T/QT-303

## AIR TYRE BUFFER/QUICK CHANGE CHUCK



20 pieces in one carton

2pcs Planet Gear with bearing

Stylized grip



| Item No. | Chuck Size      | Collet Size | Free Speed | Avg. Air Consumption | Air Pressure | Overall Length | Motor | Net Weight |      | Air Hose | Sound Pressure | Vibration Level  | Air Inlet |
|----------|-----------------|-------------|------------|----------------------|--------------|----------------|-------|------------|------|----------|----------------|------------------|-----------|
|          | inch(mm)        | inch(mm)    | R.P.M      | CFM (L/min)          | PSI (bar)    | Inch (mm)      | HP    | LBS        | kg   | Inch     | dBA            | m/s <sup>2</sup> | Inch      |
| QT-102   | ---             | 1/4"(6)     | 7500       | 3.0(85)              | 90(6.3)      | 5-1/2"(140)    | 0.3   | 0.9        | 0.41 | 3/8"     | 77.0           | 1.3              | 1/4"      |
| QT-103   | ---             | 1/4"(6)     | 7500       | 3.0(85)              | 90(6.3)      | 5-1/2"(140)    | 0.3   | 0.9        | 0.41 | 3/8"     | 77.0           | 1.3              | 1/4"      |
| QT-203   | Hex.7/16"(11.1) | ---         | 4000       | 10.6(300)            | 90(6.3)      | 9-3/4"(250)    | 0.5   | 1.76       | 0.80 | 3/8"     | 75.0           | 0.87             | 1/4"      |
| QT-113   | Hex.7/16"(11.1) | ---         | 2500       | 10.6(300)            | 90(6.3)      | 9-3/4"(250)    | 0.5   | 1.76       | 0.80 | 3/8"     | 75.0           | 0.87             | 1/4"      |
| QT-112T  | ---             | 1/4"(6)     | 4000       | 5.0(141)             | 90(6.3)      | 8-27/32"(225)  | 0.5   | 1.72       | 0.78 | 3/8"     | 85.0           | 1.2              | 1/4"      |
| QT-203T  | Hex.7/16"(11.1) | ---         | 4000       | 5.0(141)             | 90(6.3)      | 8-27/32"(225)  | 0.5   | 1.98       | 0.90 | 3/8"     | 85.0           | 1.6              | 1/4"      |
| QT-303   | Hex.7/16"(11.1) | ---         | 22000      | 5.0(141)             | 90(6.3)      | 8-9/16"(217)   | 0.5   | 1.74       | 0.79 | 3/8"     | 85.0           | 1.6              | 1/4"      |

# SK-1010

## AIR CAULKING GUN

10 pieces in one carton



# SK-1131

## AIR CAULKING GUN

6 pieces in one carton

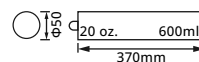
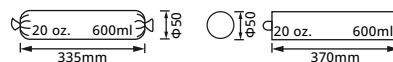

| Item No. | Capacity            | Overall Length | Avg. Air Consumption | Air Pressure   | Net Weight |      | Air Hose | Air Inlet |
|----------|---------------------|----------------|----------------------|----------------|------------|------|----------|-----------|
|          | ml(oz)              | inch(mm)       | CFM (L/min)          | PSI (bar)      | LBS        | kg   | Inch     | Inch      |
| SK-1010  | 300(13.5)           | 12"(305)       | 4.0(113)             | 50-70(3.4-4.8) | 2.4        | 1.1  | 3/8"     | 1/4"      |
| SK-1131  | 300(13.5) / 600(20) | 24-7/16"(620)  | 4.0(113)             | 60-90(4.1-6.2) | 2.66       | 1.21 | 3/8"     | 1/4"      |

# AUTO REPAIR TOOL

## QB-0808 QB-0808U For USA

**AIR SURFACE-CLEANING TOOL**



10 pieces in one carton

### Contents

- 1pc - Air Surface-Cleaning Tool (QB-802)
- 1pc - Eraser Wheel
- 1pc - Stripping Wheel
- 1pc - Wire Wheel (Coarse)
- 1pc - Wire Wheel
- 1pc - Allen Key 6mm
- 1pc - Spanner Wrench
- 1pc - 1/4" Plug
- Adapter Male UNF 5/16"-24
- 1pc - Female M6x1.0



## QB-802 QB-802U For USA

**AIR SURFACE-CLEANING TOOL**



10 pieces in one carton



## QB-802T QB-802TU For USA

**AIR ERASER**



10 pieces in one carton



## QB-812 QB-812U For USA

**AIR ERASER**



10 pieces in one carton



## QB-812T QB-812TU For USA

**AIR ERASER**



10 pieces in one carton



| Item No. | Spindle Size | Free Speed | Avg. Air Consumption | Air Pressure | Overall Length | Motor | Net Weight |      | Air Hose | Sound Pressure | Vibration Level  | Air Inlet |
|----------|--------------|------------|----------------------|--------------|----------------|-------|------------|------|----------|----------------|------------------|-----------|
|          |              | R.P.M      | CFM (L/min)          | PSI (bar)    | Inch (mm)      | HP    | LBS        | kg   | Inch     | dBA            | m/s <sup>2</sup> | Inch      |
| QB-802   | 3/8"-24      | 3600       | 10.6(300)            | 90(6.3)      | 7-7/8"(200)    | 0.7   | 2.6        | 1.2  | 3/8"     | 86             | 0.3              | 1/4"      |
| QB-802T  | 3/8"-24      | 4000       | 5.0(141)             | 90(6.3)      | 8-5/32"(212)   | 0.5   | 3.08       | 1.40 | 3/8"     | 85.0           | 1.2              | 1/4"      |
| QB-812   | 3/8"-24      | 4000       | 10.0(283)            | 90(6.3)      | 8-7/8"(225)    | 0.5   | 1.7        | 0.8  | 3/8"     | 75             | 0.87             | 1/4"      |
| QB-812T  | 3/8"-24      | 4000       | 5.0(141)             | 90(6.3)      | 8-15/32"(215)  | 0.5   | 1.67       | 0.76 | 3/8"     | 85.0           | 1.2              | 1/4"      |

## SM-111R

**AIR DENT PULLER**



4 pieces in one carton



### FEATURES

- Large area and slight depression of the sheet metal can be quickly repaired.
- Three sizes of suction cups can be used in different areas of depression.
- Simple structure and long product life.

| Item No. | Pad Dia                | Exhaust Direction | Maximum Pulling Force | Air Pressure | Overall Length | Avg. Air Consumption | Net Weight |      | Slide Hammer Weight | Air Inlet |      |
|----------|------------------------|-------------------|-----------------------|--------------|----------------|----------------------|------------|------|---------------------|-----------|------|
|          | inch(mm)               |                   | kg                    | PSI (bar)    | Inch (mm)      | CFM (L/min)          | LBS        | kg   | LBS                 | kg        | Inch |
| SM-111R  | 3",4.5",6"(78,115,155) | Rear              | 90-100                | 90(6.3)      | 44-1/8"(1120)  | 8.5(240)             | 6.0        | 2.75 | 3.5                 | 1.6       | 1/4" |

# QM-1125

## PNEUMATIC CV JOINT BOOTS FITTING TOOL



4 pieces in one carton



### FEATURES

- This air powered tool is designed and constructed to be used for installing CV boots of cars, small vans, and light duty commercial vehicles. Any other not intended use is forbidden.

| Item No. | Capacity          | Overall Length | Max Air Pressure | Air Pressure | Net Weight |      | Air Hose | Air Inlet |
|----------|-------------------|----------------|------------------|--------------|------------|------|----------|-----------|
|          | inch(mm)          | inch(mm)       | PSI (bar)        | PSI (bar)    | LBS        | kg   | Inch     | Inch      |
| QM-1125  | 1"~4-3/8"(25-110) | 17-3/8"(442)   | 125(8.6)         | 90(6.3)      | 7.15       | 3.25 | 3/8"     | 1/4"      |

## SB-201

### DIGITAL TYRE INFLATOR

20 pieces in one carton



## SB-215

### DIGITAL TYRE INFLATOR

12 pieces in one carton



## SB-3030

### DIGITAL TYRE INFLATOR

12 pieces in one carton



## SB-3038

### DIGITAL TYRE INFLATOR

20 pieces in one carton



## SB-3130

### DIGITAL TYRE INFLATOR

20 pieces in one carton



## SB-422

### TYRE INFLATOR

20 pieces in one carton



## SB-423

### TYRE INFLATOR

12 pieces in one carton



## SB-710

### TYRE INFLATOR

12 pieces in one carton



## SB-2031

## SB-2131

### TYRE INFLATOR

20 pieces in one carton



- Dial face size : Ø3.5"
- SB-2031 : Short piping
- SB-2131 : Long piping 100cm

## SB-4031

## SB-4151

### TYRE INFLATOR

20 pieces in one carton



- Dial face size : Ø3.5"
- SB-4031 : Short piping
- SB-4151 : Long piping 150cm

## SB-501

### TYRE INFLATOR

12 pieces in one carton



| Item No. | Max Pressure | Nozzle Length | Air Consumption at 100PSI | Air Pressure | Net Weight |      | Air Hose | Air Inlet | Nozzle          |
|----------|--------------|---------------|---------------------------|--------------|------------|------|----------|-----------|-----------------|
|          | PSI (bar)    | cm            | CFM                       | PSI (bar)    | LBS        | kg   | Inch     | Inch      |                 |
| SB-201   | 160(11.0)    | 30            | 1.41                      | 90(6.3)      | 0.70       | 0.32 | 3/8"     | 1/4"      | Tyre valve clip |
| SB-215   | 160(11.0)    | 150           | 1.41                      | 90(6.3)      | 0.88       | 0.40 | 3/8"     | 1/4"      | Tyre valve clip |
| SB-3030  | 200(14.0)    | 30            | 1.41                      | 90(6.3)      | 1.08       | 0.49 | 3/8"     | 1/4"      | Tyre valve clip |
| SB-3038  | 200(14.0)    | 100           | 1.41                      | 90(6.3)      | 1.49       | 0.68 | 3/8"     | 1/4"      | Tyre valve clip |
| SB-3130  | 200(14.0)    | 100           | 1.41                      | 90(6.3)      | 1.3        | 0.6  | 3/8"     | 1/4"      | Tyre valve clip |
| SB-422   | 160(11.0)    | 45            | 1.41                      | 90(6.3)      | 1.21       | 0.55 | 3/8"     | 1/4"      | Tyre valve clip |
| SB-423   | 220(15.0)    | 100           | 1.41                      | 90(6.3)      | 2.92       | 1.33 | 3/8"     | 1/4"      | Tyre valve clip |
| SB-710   | 200(13.8)    | 100           | 1.41                      | 90(6.3)      | 1.0        | 0.5  | 3/8"     | 1/4"      | Tyre valve clip |
| SB-2031  | 160(11.0)    | 30            | 1.41                      | 90(6.3)      | 1.32       | 0.6  | 3/8"     | 1/4"      | One touch clip  |
| SB-2131  | 160(11.0)    | 150           | 1.41                      | 90(6.3)      | 1.43       | 0.65 | 3/8"     | 1/4"      | One touch clip  |
| SB-4031  | 160(11.0)    | 30            | 1.41                      | 90(6.3)      | 1.32       | 0.6  | 3/8"     | 1/4"      | One touch clip  |
| SB-4151  | 160(11.0)    | 150           | 1.41                      | 90(6.3)      | 1.43       | 0.65 | 3/8"     | 1/4"      | One touch clip  |
| SB-501   | 160(11.0)    | 30            | 1.41                      | 90(6.3)      | 2.92       | 1.33 | 3/8"     | 1/4"      | Dual chuck      |

# AUTO REPAIR TOOL

## SM-0503

### PNEUMATIC BRAKE EXTRACTOR & REFILLED KIT

1 pieces in one carton



## SM-0813

### MANUAL & FLUID EXTRACTOR

4 pieces in one carton



| Item No. | Air Pressure |      | Net Weight |     | Capacity | Air Inlet |
|----------|--------------|------|------------|-----|----------|-----------|
|          | PSI          | LBS  | kg         | L   | Inch     |           |
| SM-0503  | 70-170       | 4.12 | 1.86       | 3.0 | 1/4"     |           |
| SM-0813  | 70-170       | 6.80 | 2.7        | 8.0 | 1/4"     |           |

## WG-202N[SET]

### AIR SUCTION & BLOW GUN KIT

Air inlet 1/4"

10 pieces in one carton

#### Contents 8 pcs

- 1pc - Extension Tube
- 1pc - Small Diameter Vacuum Tube
- 1pc - Flat Tube
- 1pc - Brush
- 1pc - Flexible tube
- 1pc - Deflector
- 1pc - Clamping Ring
- 1pc - Dust Bag



WG-202

20 pieces in one carton



## SR-2001 KIT

### AIR BRUSH KIT

40 pieces in one carton

#### Contents 9 pcs

- 1pc - Airbrush
- 1pc - 22c.c. Glass Jar
- 1pc - 50c.c. Glass Jar
- 1pc - 55FT(M5 x 0.45) Air Hose
- 1pc - Adaptor
- 1pc - Holder
- 1pc - 2c.c. Cup
- 1pc - 8c.c. Cup
- 1pc - Spanner



## SR-2101

### AIR BRUSH SET

40 pieces in one carton

#### Contents 4 pcs

- 1pc - Air Brush
- 1pc - Pipette
- 1pc - Spanner
- 1pc - Air Adaptor



## SC-005

### BALL JOINT & TIE-ROD SPLITTER SET

10 pieces in one carton

#### Contents 5 pcs

- 1pc - Air Hammer Adapter
- 1pc - 1-1/8"(28.57mm) Pitman Arm
- 1pc - Striking Handle
- 1pc - 11/16"(17.46mm) Tie Rod
- 1pc - 15/16"(23.81mm) Ball Joint





## SE-1025

**FLEXIBLE LED LIGHT**

20 pieces in one carton



## SE-2012

**LED WORK LIGHT**

24 pieces in one carton



## SE-3001

**LED HEADLAMP**

50 pieces in one carton



## SQ-0217

**AIR POWERED BRAKE CALIIPER WIND BACK TOOL-SET 17PCS**

5 pieces in one carton

Air inlet 1/4"

• Not available in north America

**Contents 17 pcs**

- 1pc - Air Powered Brake Caliper Wind Back Tool
- 16pcs - Disk



## NEW PRODUCT

## SC-0320

**AIR VIBRATION INJECTOR PULLER**

3 pieces in one carton



### FEATURES

- Design to replace the sliding hammer without hand using.
- Save the power and time to pull out the injector from engine.
- High torque and two speeds design for pull out the injector quickly.

| Item No. | Piston Stroke | Stroke Speed | Max Torque | Spindle Thread | Working Pressure | Max. air Pressure | Overall Length | Air Hose | Weight | Air Inlet |
|----------|---------------|--------------|------------|----------------|------------------|-------------------|----------------|----------|--------|-----------|
|          | mm            | bpm          | Nm         |                | PSI (bar)        | PSI (bar)         | mm             | mm       | kg     | Inch      |
| SC-0320  | 38            | 300/900      | 600        | M18 x 1.5      | 87-130.5(6-9)    | 140.5(10)         | 500            | 12       | 2.7    | 1/4"      |



# SANDBLASTING GUN

SANDBLASTING GUN

## SX-1201 AIR UNDERSEAL GUN

☆☆☆   
20 pieces in one carton



## SX-1615 AIR CLEANING GUN

☆☆☆   
8 pieces in one carton



## SX-1618 AIR CLEANING GUN KIT

☆☆☆   
8 pieces in one carton



## SX-2101 AIR TWISTER GUN

☆☆☆   
Not available in north America  
10 pieces in one carton



## SX-3101 AIR SANDBLASTING GUN

☆☆☆   
20 pieces in one carton



## SX-3102 AIR SANDBLASTING GUN

☆☆☆   
20 pieces in one carton



## SX-3103 AIR SANDBLASTING GUN

☆☆☆   
10 pieces in one carton



## SX-3111 AIR UNDERSEAL GUN

☆☆☆   
20 pieces in one carton



## SX-3112 AIR UNDERSEAL GUN

☆☆☆   
50 pieces in one carton



## SX-3202 SOLVENT / CLEANER SPRAY GUN

☆☆☆   
20 pieces in one carton



## SX-3203 1L CLEANING GUN

☆☆☆   
10 pieces in one carton



## SX-3301 AIR SOLVENT CLEANER SPRAY GUN

☆☆☆   
20 pieces in one carton



## SX-4101 SODA BLASTER

☆☆☆   
10 pieces in one carton



| Item No. | Cup Capacity | Free Speed | Overall Length           | Avg. Air Consumption | Air Pressure | Net Weight |      | Air Hose | Sound Pressure | Air Inlet |
|----------|--------------|------------|--------------------------|----------------------|--------------|------------|------|----------|----------------|-----------|
|          | L            | R.P.M      | inch(mm)                 | CFM (L/min)          | PSI (bar)    | LBS        | kg   | Inch     | dBA            | Inch      |
| SX-1201  | ---          | ---        | 9-9/16"(245)             | 6.2                  | 90(6.3)      | 1.43       | 0.65 | 3/8"     | ---            | 1/4"      |
| SX-1615  | 1.0          | ---        | 11-7/16"(290)            | 5.0(141.5)           | 90(6.3)      | 0.9        | 0.4  | 3/8"     | 85.0           | 1/4"      |
| SX-1618  | ---          | ---        | 14-15/16"(380)           | 5                    | 90(6.3)      | 0.44       | 0.19 | 3/8"     | ---            | 1/4"      |
| SX-2101  | 1.0          | 5500       | 8-7/32"x4-5/16"(210x110) | 2.0(56.6)            | 90(6.3)      | 1.71       | 0.78 | 3/8"     | 85.0           | 1/4"      |
| SX-3101  | 1.0          | ---        | 11"(280)                 | 4.3(121.8)           | 90(6.3)      | 1.26       | 0.57 | 3/8"     | 85.0           | 1/4"      |
| SX-3102  | 0.7          | ---        | 10-1/8"(260)             | 4.0(113.3)           | 90(6.3)      | 0.77       | 0.35 | 3/8"     | 85.0           | 1/4"      |
| SX-3103  | ---          | ---        | 122"(3100)               | 3.5(99.1)            | 90(6.3)      | 2.31       | 10.5 | 3/8"     | 80.0           | 1/4"      |
| SX-3111  | 1.0          | ---        | 10-1/8"(260)             | 3.0(84.9)            | 90(6.3)      | 0.97       | 0.44 | 3/8"     | 85.0           | 1/4"      |
| SX-3112  | ---          | ---        | 10-1/8"(260)             | 3.0(84.9)            | 90(6.3)      | 0.48       | 0.22 | 3/8"     | 85.0           | 1/4"      |
| SX-3202  | 1.0          | ---        | 20-13/16"(530)           | 1.0(56.6)            | 90(6.3)      | 1.04       | 0.47 | 3/8"     | 65.0           | 1/4"      |
| SX-3203  | 1.0          | ---        | 18-1/2"(470)             | 1.0(56.6)            | 90(6.3)      | 1.17       | 0.53 | 3/8"     | 65.0           | 1/4"      |
| SX-3301  | 1.0          | ---        | 11-13/16"(300)           | 10(300)              | 90(6.3)      | 1.52       | 0.69 | 1/4"     | 85.0           | 1/4"      |
| SX-4101  | 0.6          | ---        | 7-3/4"(197)              | 8.0(226.5)           | 90(6.3)      | 0.8        | 0.36 | 3/8"     | 82.0           | 1/4"      |

# FILTER REGULATOR LUBRICATOR



FILTER REGULATOR LUBRICATOR

**SV-1240**  
FILTER, REGULATOR



**SV-1260**  
**SV-1360**  
FILTER, REGULATOR



**SV-1460**  
FILTER, REGULATOR,  
LUBRICATOR



**SV-1660**  
**SV-1860**  
FILTER, REGULATOR,  
LUBRICATOR



**SV-2220**  
FILTER, REGULATOR,  
LUBRICATOR



**SV-2260/SV-2280**  
**SV-2360/SV-2380**  
FILTER, REGULATOR, LUBRICATOR



**SV-2431**  
FILTER, REGULATOR,  
LUBRICATOR



# FILTER REGULATOR LUBRICATOR

FILTER REGULATOR LUBRICATOR

**SV-2460**  
FILTER, REGULATOR,  
LUBRICATOR



**SV-2660**  
**SV-2860**  
FILTER, REGULATOR,  
LUBRICATOR



**SV-3260**  
**SV-3360**  
FILTER, REGULATOR,  
LUBRICATOR



**SV-3460**  
FILTER, REGULATOR,  
LUBRICATOR



**SV-3660/SV-3860**  
FILTER, REGULATOR, LUBRICATOR



SV-3660



SV-3860

**SW-12(1/4")/SW-13(3/8")**  
MINI LUBRICATOR



SW-12



SW-13

| Item No.        | Air in / outlet | Max Input Pressure | Max Output Pressure | Max. Flow   | Working Temperature | Drain Capacity | Oil Capacity | Filter Element |
|-----------------|-----------------|--------------------|---------------------|-------------|---------------------|----------------|--------------|----------------|
|                 | inch            | PSI                | PSI                 | L/min       | °C                  | ml             | ml           | μ(micro)       |
| SV-1240         | 1/4"            | 150                | 145                 | 1100        | 5-60°               | 15             | ---          | 5μ             |
| SV-1260         | 1/4"            | 215                | 145                 | 1750        | 5-60°               | 80             | ---          | 5μ             |
| SV-1360         | 3/8"            | 215                | 145                 | 2500        | 5-60°               | 80             | ---          | 5μ             |
| SV-1460         | 1/2"            | 215                | 145                 | 3000        | 5-60°               | 80             | ---          | 5μ             |
| SV-1660         | 3/4"            | 250                | 225                 | 4600        | 5-60°               | 300            | ---          | 5μ             |
| SV-1860         | 1"              | 250                | 225                 | 5200        | 5-60°               | 300            | ---          | 5μ             |
| SV-2220         | 1/4"            | 150                | 70-140              | 1100        | 5-60°               | 15             | 30           | 5μ             |
| SV-2260/SV-2360 | 1/4" / 3/8"     | 215                | 70-150              | 1750 / 2500 | 5-60°               | 80             | 150          | 5μ             |
| SV-2280/SV-2380 | 1/4" / 3/8"     | 250                | 70-140              | 1750 / 2500 | 5-60°               | 80             | 150          | 5μ             |
| SV-2431         | 1/2"            | 285                | 70-140              | 3400        | 5-60°               | 80             | 200          | 5μ             |
| SV-2460         | 1/2"            | 250                | 7-215               | 4000        | 5-60°               | 80             | 150          | 5μ             |
| SV-2660/SV-2860 | 3/4" / 1"       | 250                | 225                 | 4600 / 5200 | 5-60°               | 300            | 300          | 5μ             |
| SV-3260/SV-3360 | 1/4" / 3/8"     | 215                | 70-150              | 1750 / 2500 | 5-60°               | 80             | 150          | 5μ             |
| SV-3460         | 1/2"            | 250                | 7-215               | 4000        | 5-60°               | 80             | 150          | 5μ             |
| SV-3660/SV-3860 | 3/4" / 1"       | 250                | 225                 | 4600 / 5200 | 5-60°               | 300            | 350          | 5μ             |

# AIR HOSE REEL

## SA-2015

**AIR HOSE REEL**  
Case Material : Steel

2 pieces in one carton



## SA-3215 SA-3315

**AIR HOSE REEL**  
Case Material : Shock-Proof Plastic

2 pieces in one carton



## SA-4320

**AIR HOSE REEL**

1 pieces in one carton



## SD-23/SD-24

**POLYURETHANE RECOIL AIR-HOSE**

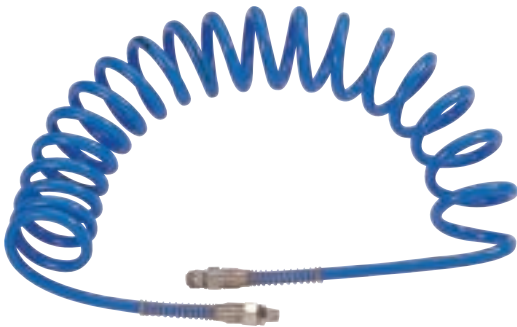

## SD-22

**8 x 12 AIR HOSE**



| Item No. | Hose Inside Diameter | Hose Outside Diameter | Hose Length | Working Pressure | Maximum Pressure | Male PT Fitting | Weight |
|----------|----------------------|-----------------------|-------------|------------------|------------------|-----------------|--------|
|          | mm                   | mm                    | M           | PSI(bar)         | PSI(bar)         | inch            | kg     |
| SA-2015  | 8.0                  | 12.0                  | 15          | 101.5(7.0)       | 284.4(17.8)      | 1/4"            | 6.2    |
| SA-3215  | 8.0                  | 12.0                  | 15          | 90(6.3)          | 300(20.7)        | 1/4"            | 5.0    |
| SA-3315  | 10.0                 | 15.0                  | 15          | 90(6.3)          | 300(20.7)        | 3/8"            | 6.0    |
| SA-4320  | 10.0                 | 18.0                  | 20          | 90(6.3)          | 300(20.7)        | 3/8"            | 24.0   |
| SD-22107 | 8.0                  | 12.0                  | 7.5         | 101.5(7.0)       | 284.4(17.8)      | 1/4"            | 0.8    |
| SD-22115 | 8.0                  | 12.0                  | 15          | 101.5(7.0)       | 284.4(17.8)      | 1/4"            | 1.4    |
| SD-22130 | 8.0                  | 12.0                  | 30          | 101.5(7.0)       | 284.4(17.8)      | 1/4"            | 2.6    |
| SD-23110 | 8.0                  | 12.0                  | 10          | 101.5(7.0)       | 284.4(17.8)      | 1/4"            | 0.8    |
| SD-23115 | 8.0                  | 12.0                  | 15          | 101.5(7.0)       | 284.4(17.8)      | 1/4"            | 1.2    |
| SD-23210 | 5.0                  | 8.0                   | 10          | 101.5(7.0)       | 284.4(17.8)      | 1/4"            | 0.4    |
| SD-23215 | 5.0                  | 8.0                   | 15          | 101.5(7.0)       | 284.4(17.8)      | 1/4"            | 0.6    |
| SD-23315 | 10                   | 15.0                  | 15          | 101.5(7.0)       | 284.4(17.8)      | 3/8"            | 1.9    |
| SD-24415 | 13                   | 18.0                  | 15          | 101.5(7.0)       | 284.4(17.8)      | 1/2"            | 2.1    |

# TORQUE WRENCH

## ★★ TE-81N/TE-82N TE-83N/TE-84N/TE-85N

1" TORQUE WRENCH, ENGRAVE. NM / FT-LB SCALE



2 pieces in one carton

1 pieces in one carton

TE-81N/TE-82N

TE-83N/TE-84N/TE-85N

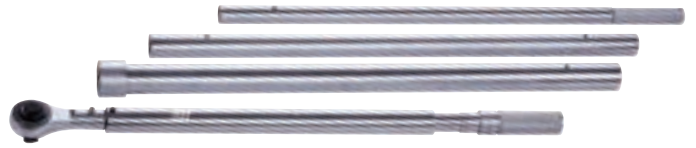

| Item No.   | Drive | Gear | Torque Range       | Indicator | Torque Adjusting | D    | H    | L    | Weight |
|------------|-------|------|--------------------|-----------|------------------|------|------|------|--------|
|            | Inch  | T    | FT-LB(Nm)          |           |                  | mm   | mm   | mm   | kg     |
| TE-815080N | 1"    | 24   | 129-572(150-180)   | Engraved  | Rotating         | ---  | ---  | 1240 | 6.1    |
| TE-820100N | 1"    | 24   | 166-719(200-1000)  | Engraved  | Rotating         | 70.2 | 72.1 | 1240 | 6.4    |
| TE-830150N | 1"    | 24   | 258-1070(300-1500) | Engraved  | Rotating         | ---  | ---  | 1850 | 10.6   |
| TE-840200N | 1"    | 36   | 369-1402(400-2000) | Engraved  | Rotating         | ---  | ---  | 2300 | 18.3   |
| TE-850250N | 1"    | 36   | 443-1771(500-2500) | Engraved  | Rotating         | 74.5 | 66.1 | 2755 | 19.6   |

## ★★ TM-0416 TM-0418

TORQUE MULTIPLIER

2 pieces in one carton

- Works with high transmission efficiency by planet gears
- 5:1 torque multiplication
- Multiplication accuracy ±5%
- Supplied with 2 reaction bar styles



## ★★ TM-0428-1 TM-0428-2

TORQUE MULTIPLIER

1 pieces in one carton

- Multiplication deviation less than ±5%
- Mechanism with high ratio gearbox 26:1
- High ratios offer benefits without using long lever arms or heavy wrenches
- Supplied with 2 different reaction bar
- Durable construction without maintenance necessary and long lifetime



## ★★ TM-0618

TORQUE MULTIPLIER

2 pieces in one carton

- Planetary gear carrier mechanism makes high transmission efficiency and load capacity.
- 5:1 torque multiplication.
- Multiplication accuracy ±5%.
- Supplied with 2 reaction bars.



| Item No.  | Input Square | Output Square | Max Rated Output | Ratio  | Net Weight |      |
|-----------|--------------|---------------|------------------|--------|------------|------|
|           | Inch         | Inch          | FT-LB(Nm)        |        | LBS        | kg   |
| TM-0416   | 1/2"         | 3/4"          | 1100(1500)       | 5:1    | 14.2       | 6.48 |
| TM-0418   | 1/2"         | 1"            | 1100(1500)       | 5:1    | 14.2       | 6.48 |
| TM-0428-1 | 1/2"         | 1"            | 2200(3000)       | 15.5:1 | 25.4       | 11.5 |
| TM-0428-2 | 1/2"         | 1"            | 3300(4500)       | 26:1   | 28.7       | 13   |
| TM-0618   | 3/4"         | 1"            | 2000(2700)       | 5:1    | 14.2       | 6.48 |

## ★★ PROFESSIONAL SERISE TORQUE WRENCH

WINDOW DISPLAY. Nm / ft-lb scale, Back Turning

TW-210222/TW-310552/TW-411102/TW-412202

24 pieces in one carton

24 pieces in one carton

12 pieces in one carton

12 pieces in one carton



## ★★ CLASSIC SERIES TORQUE WRENCH

TE-205025N/TE-225250N/TE-305025N/TE-320110N/TE-442210N  
TE-428210N/TE-450350N

1/2" TORQUE WRENCH, 42-210 Nm, Engraved Nm / ft-lb scale



24 pieces in one carton

12 pieces in one carton

TE-205025N/TE-225250N  
TE-305025N

TE-320110N/TE-442210N  
TE-428210N/TE-450350N



## ☆☆ MICRO-ADJUSTABLE TORQUE WRENCH SERIES

### TB-205025N/TB-305025N/TB-320110N/TB-420210N/TB-450350N TB-610060N/TB-615080N/TB-620100N

24 pieces in one carton

12 pieces in one carton

10 pieces in one carton

2 pieces in one carton

TB-205025N/TB-305025N

TB-320110N

TB-450350N

TB-610060N/TB-615080N/TB-620100N



## ☆☆ PROFESSIONAL REVERSIBLE SERIES TORQUE WRENCH

### TD-202025/TD-305050/TD-410100/TD-420200/TD-610060

24 pieces in one carton

12 pieces in one carton

2 pieces in one carton

TD-202025/TD-305050

TD-410100/TD-420200

TD-610060



## ☆☆ PROFESSIONAL SERIES TORQUE WRENCH

### TW-611602/TW-611802/TW-612102

3/4" TORQUE WRENCH, WINDOW DISPLAY. Nm / ft-lb scale, Back Turning

2 pieces in one carton



| Item No.   | Drive | Gear | Torque Range |            |            | Indicator        | Torque Adjusting | D    | H    | L    | Weight |
|------------|-------|------|--------------|------------|------------|------------------|------------------|------|------|------|--------|
|            | Inch  | T    | Nm           | FT-LB      | in-lb      |                  |                  | mm   | mm   | mm   | kg     |
| TW-210222  | 1/4"  | 24   | 2-25         | 1.5-18     | ---        | Magnifying glass | Back Turning     | 28.0 | 23   | 296  | 0.41   |
| TW-310552  | 3/8"  | 24   | 5-50         | 3.5-37     | ---        | Magnifying glass | Back Turning     | 28.0 | 28   | 333  | 0.47   |
| TW-411102  | 1/2"  | 32   | 10-100       | 8-75       | ---        | Magnifying glass | Back Turning     | 40.5 | 40   | 400  | 0.82   |
| TW-412202  | 1/2"  | 32   | 20-200       | 10-150     | ---        | Magnifying glass | Back Turning     | 40.5 | 40   | 500  | 1.3    |
| TE-205025N | 1/2"  | 24   | 5-25         | ---        | 53.1-212.4 | Engraved         | Rotating         | 32   | 31.8 | 275  | 0.59   |
| TE-225250N | 1/4"  | 24   | 2.8-28.2     | ---        | 25-250     | Engraved         | Rotating         | 32   | 31.8 | 275  | 0.59   |
| TE-305025N | 3/8"  | 24   | 5-25         | ---        | 53.1-212.4 | Engraved         | Rotating         | 32   | 31.8 | 370  | 0.83   |
| TE-320110N | 3/8"  | 24   | 20-110       | 14.8-81.1  | ---        | Engraved         | Rotating         | 32   | 31.8 | 370  | 0.83   |
| TE-442210N | 1/2"  | 24   | 42-210       | 30.6-155   | ---        | Engraved         | Rotating         | 46.3 | 33   | 450  | 1.32   |
| TE-428210N | 1/2"  | 24   | 28-210       | 20.7-154.9 | ---        | Engraved         | Rotating         | 46.3 | 33   | 570  | 1.65   |
| TE-450350N | 1/2"  | 24   | 50-350       | 36.9-258.1 | ---        | Engraved         | Rotating         | 46.3 | 33   | 450  | 1.31   |
| TB-205025N | 1/4"  | 24   | 5-25         | ---        | 53.1-212.4 | Engraved         | Rotating         | 32   | 31.8 | 281  | 0.53   |
| TB-305025N | 3/8"  | 24   | 5-25         | ---        | 53.1-212.4 | Engraved         | Rotating         | 32   | 31.8 | 361  | 0.77   |
| TB-320110N | 3/8"  | 24   | 20-110       | 18.5-77.5  | ---        | Engraved         | Rotating         | 32   | 31.8 | 361  | 0.77   |
| TB-420210N | 1/2"  | 24   | 20-210       | 18.4-151.2 | ---        | Engraved         | Rotating         | 40.5 | 40   | 461  | 1.25   |
| TB-450350N | 1/2"  | 24   | 50-350       | 48.0-247.2 | ---        | Engraved         | Rotating         | 40.5 | 40   | 553  | 1.59   |
| TB-610060N | 3/4"  | 24   | 100-600      | 92.0-424   | ---        | Engraved         | Back Turning     | 63   | 58   | 1010 | 4.73   |
| TB-615080N | 3/4"  | 24   | 150-800      | 129-572    | ---        | Engraved         | Rotating         | 63   | 58   | 1010 | 2.41   |
| TB-620100N | 3/4"  | 24   | 200-1000     | 166-719    | ---        | Engraved         | Back Turning     | 63   | 58   | 1200 | 5.99   |
| TD-202025  | 1/4"  | 72   | 2-25         | 1.5-1.8    | ---        | Magnifying glass | Back Turning     | 40.5 | 40   | 298  | 0.41   |
| TD-305050  | 3/8"  | 72   | 5-50         | 3.5-37     | ---        | Magnifying glass | Back Turning     | 40.5 | 40   | 363  | 0.47   |
| TD-410100  | 1/2"  | 72   | 10-100       | 8-75       | ---        | Magnifying glass | Back Turning     | 40.5 | 40   | 445  | 1.1    |
| TD-420200  | 1/2"  | 72   | 20-200       | 10-150     | ---        | Magnifying glass | Back Turning     | 40.5 | 40   | 513  | 1.28   |
| TD-610060  | 3/4"  | 72   | 100-600      | 75-440     | ---        | Magnifying glass | Back Turning     | 40.5 | 40   | 1040 | 4.65   |
| TW-611602  | 3/4"  | 24   | 100-600      | 75-440     | ---        | Magnifying glass | Back Turning     | 63   | 58.5 | 1040 | 4.65   |
| TW-611802  | 3/4"  | 24   | 150-800      | 110-590    | ---        | Magnifying glass | Back Turning     | 63   | 58.5 | 1240 | 5.45   |
| TW-612102  | 3/4"  | 24   | 200-1000     | 150-740    | ---        | Magnifying glass | Back Turning     | 63   | 58.5 | 1240 | 5.5    |

# TORQUE WRENCH

TORQUE WRENCH



## ★★ CLASSIC SERIES TORQUE WRENCH

### TF-310080N/TF-430250N

3/8" & 1/2" DRIVE FLEX-HEAD TORQUE WRENCH

12 pieces in one carton



## ★★ SPLIT-BEAM SERIES TORQUE WRENCH

### TS-320100N/TS-440250N

3/8" & 1/2" DRIVE FLEXIBLE SPLIT-BEAM TORQUE WRENCH

12 pieces in one carton 10 pieces in one carton



| Item No.   | Drive | Gear | Torque Range | Indicator | Torque Adjusting | D    | H    | L   | Weight |
|------------|-------|------|--------------|-----------|------------------|------|------|-----|--------|
|            | Inch  | T    | FT-LB        |           |                  | mm   | mm   | mm  | kg     |
| TF-310080N | 3/8"  | 32   | 10-80        | Engraved  | Rotating         | 36.8 | 30.4 | 465 | 11.1   |
| TF-430250N | 1/2"  | 32   | 30-250       | Engraved  | Rotating         | 43.3 | 40.5 | 640 | 1.94   |
| TS-320100N | 3/8"  | 32   | 20-100       | Engraved  | Flexible         | 35.2 | 27.8 | 476 | 0.95   |
| TS-440250N | 1/2"  | 32   | 40-250       | Engraved  | Flexible         | 44.1 | 36.1 | 590 | 1.7    |

# DIGITAL TORQUE WRENCH

## ☆☆☆☆ **GTF-203030**

**1/4" DIGITAL FLEXIBLE TORQUE WRENCH** Accuracy : clockwise +/- 2% counterclockwise +/- 3%

8 pieces in one carton



## ☆☆☆☆ **GTF-313135**

**3/8" DIGITAL FLEXIBLE TORQUE WRENCH** Accuracy : clockwise +/- 2% counterclockwise +/- 3%

6 pieces in one carton



## ☆☆☆☆ **GTF-420200/GTF-434340**

**1/2" DIGITAL FLEXIBLE TORQUE WRENCH** Accuracy : clockwise +/- 2% counterclockwise +/- 3%

4 pieces in one carton



## ☆☆☆☆ **GTA-201030**

**1/4" DIGITAL ANGLE TORQUE WRENCH** Accuracy : clockwise +/- 1.5% counterclockwise +/- 2.5%

8 pieces in one carton



## ☆☆☆☆ **GTA-306135**

**3/8" DIGITAL ANGLE TORQUE WRENCH** Accuracy : clockwise +/- 1.5% counterclockwise +/- 2.5%

6 pieces in one carton



## ☆☆☆☆ **GTA-406135/GTA-410200**

**1/2" DIGITAL ANGLE TORQUE WRENCH** Accuracy : clockwise +/- 1.5% counterclockwise +/- 2.5%

6 pieces in one carton 4 pieces in one carton



## ☆☆☆☆ **GTA-417340**

**1/2" DIGITAL ANGLE TORQUE WRENCH** Accuracy : clockwise +/- 1.5% counterclockwise +/- 2.5%

4 pieces in one carton



## ☆☆☆☆ **GTA-606060/GTA-610100**

**3/4" DIGITAL ANGLE TORQUE WRENCH** Accuracy : clockwise +/- 1.5% counterclockwise +/- 2.5%

1 pieces in one carton



## ☆☆☆☆ **GTA-810100**

**1" DIGITAL ANGLE TORQUE WRENCH** Accuracy : clockwise +/- 1.5% counterclockwise +/- 2.5%

1 pieces in one carton



## ☆☆☆☆ **GTB-201030**

**1/4" DIGITAL FLEXIBLE & ANGLE TORQUE WRENCH** Accuracy : clockwise +/- 2% counterclockwise +/- 3%

8 pieces in one carton



## ☆☆☆☆ **GTB-306135**

**3/8" DIGITAL FLEXIBLE & ANGLE TORQUE WRENCH** Accuracy : clockwise +/- 2% counterclockwise +/- 3%

6 pieces in one carton



DIGITAL TORQUE WRENCH



# DIGITAL TORQUE WRENCH

## ★★ **GTB-410200/GTB-417340**

**1/2" DIGITAL FLEXIBLE TORQUE WRENCH** Accuracy : clockwise +/- 2% counterclockwise +/- 3%

4 pieces in one carton



## ★★ **GMS-203006/GMS-207015/GMS-212025**

**1/4" MINI DIGITAL TORQUE WRENCH (SQUARE)** Accuracy : clockwise +/- 3% counterclockwise +/- 4%

10 pieces in one carton



## ★★ **GMH-203006/GMH-207015/GMH-212025**

**1/4" MINI DIGITAL TORQUE WRENCH (BIT)** Accuracy : clockwise +/- 3% counterclockwise +/- 4%



## ★★ **GMI-206006/GMI-215015/GMI-225025**

**1/4" MINI DIGITAL INTERCHANGABLE TORQUE WRENCH** Accuracy : clockwise +/- 3% counterclockwise +/- 4%



| Item No.   | Drive     | Gear | Torque Range |            | Indicator | Torque Adjusting  | D    | H  | L    | Weight |
|------------|-----------|------|--------------|------------|-----------|---|------|----|------|--------|
|            | Inch      | T    | Nm           | FT-LB      | LCD       |  | mm   | mm | mm   | kg     |
| GTF-203030 | 1/4"      | 72   | 3-30         | 2.2-22.13  | LCD       | Digital   | 38   | 38 | 446  | 0.74   |
| GTF-313135 | 3/8"      | 72   | 13.5-135     | 10-99.6    | LCD       | Digital   | 38   | 38 | 446  | 0.9    |
| GTF-420200 | 1/2"      | 72   | 20-200       | 14.8-147.5 | LCD       | Digital   | 38   | 41 | 572  | 1.312  |
| GTF-434340 | 1/2"      | 72   | 34-340       | 25-250.8   | LCD       | Digital   | 38   | 41 | 670  | 1.442  |
| GTA-201030 | 1/4"      | 72   | 1.5-30       | 1.11-22.13 | LCD       | Digital   | 38   | 38 | 410  | 0.71   |
| GTA-306135 | 3/8"      | 72   | 6.8-135      | 5.0-99.6   | LCD       | Digital   | 38   | 38 | 432  | 0.84   |
| GTA-406135 | 1/2"      | 72   | 6.8-135      | 5.0-99.6   | LCD       | Digital   | 38   | 41 | 296  | 0.41   |
| GTA-410200 | 1/2"      | 72   | 10-200       | 7.4-147.5  | LCD       | Digital   | 38   | 41 | 566  | 1.2    |
| GTA-417340 | 1/2"      | 72   | 17-340       | 12.5-250.8 | LCD       | Digital   | 38   | 41 | 622  | 1.4    |
| GTA-606060 | 3/4"      | 24   | 60-600       | 44.3-442.5 | LCD       | Digital   | 63   | 58 | 943  | 3.8    |
| GTA-610100 | 3/4"      | 24   | 100-1000     | 73.8-737.6 | LCD       | Digital   | 63   | 58 | 1235 | 4.6    |
| GTA-810100 | 1"        | 24   | 100-1000     | 73.8-737.6 | LCD       | Digital   | 69.3 | 70 | 1235 | 4.9    |
| GTB-201030 | 1/4"      | 72   | 3-30         | 2.22-22.13 | LCD       | Digital   | 38   | 38 | 413  | 0.74   |
| GTB-306135 | 3/8"      | 72   | 13.5-135     | 10-99.6    | LCD       | Digital   | 38   | 38 | 446  | 0.9    |
| GTB-410200 | 1/2"      | 72   | 20-200       | 14.8-174.5 | LCD       | Digital   | 38   | 41 | 572  | 1.3    |
| GTB-417340 | 1/2"      | 72   | 34-340       | 25-250     | LCD       | Digital   | 38   | 41 | 670  | 1.4    |
| GMS-203006 | 1/4"      | 72   | 0.3-6        | ---        | LCD       | Digital   | 27   | 27 | 243  | 0.19   |
| GMS-207015 | 1/4"      | 72   | 0.75-15      | ---        | LCD       | Digital   | 27   | 27 | 243  | 0.19   |
| GMS-212025 | 1/4"      | 72   | 1.25-25      | ---        | LCD       | Digital   | 27   | 27 | 243  | 0.19   |
| GMH-203006 | 1/4"(BIT) | 72   | 0.3-6        | ---        | LCD       | Digital   | 27   | 27 | 243  | 0.19   |
| GMH-207015 | 1/4"(BIT) | 72   | 0.75-15      | ---        | LCD       | Digital   | 27   | 27 | 243  | 0.19   |
| GMH-212025 | 1/4"(BIT) | 72   | 1.25-25      | ---        | LCD       | Digital   | 27   | 27 | 243  | 0.19   |
| GMI-206006 | 1/4"      | 72   | 0.6-6        | ---        | LCD       | Digital   | 27   | 27 | 243  | 2.5    |
| GMI-215015 | 1/4"      | 72   | 1.5-15       | ---        | LCD       | Digital   | 27   | 27 | 243  | 2.5    |
| GMI-225025 | 1/4"      | 72   | 2.5-25       | ---        | LCD       | Digital   | 27   | 27 | 243  | 2.5    |

**GTW-201030**

**1/4" DIGITAL TORQUE WRENCH** Accuracy : clockwise +/- 1.5% counterclockwise +/- 2.5%

8 pieces in one carton



**GTW-306135**

**3/8" DIGITAL TORQUE WRENCH** Accuracy : clockwise +/- 1.5% counterclockwise +/- 2.5%

6 pieces in one carton



**GTW-406135/GTW-410200**

**1/2" DIGITAL TORQUE WRENCH** Accuracy : clockwise +/- 1.5% counterclockwise +/- 2.5%

6 pieces in one carton 4 pieces in one carton



**GTW-417340**

**1/2" DIGITAL TORQUE WRENCH** Accuracy : clockwise +/- 1.5% counterclockwise +/- 2.5%

4 pieces in one carton



**GTW-606060**

**3/4" DIGITAL TORQUE WRENCH** Accuracy : clockwise +/- 1.5% counterclockwise +/- 2.5%

1 pieces in one carton



**GTW-610100/GTW-810100**

**3/4" / 1" DIGITAL TORQUE WRENCH** Accuracy : clockwise +/- 1.5% counterclockwise +/- 2.5%

1 pieces in one carton



**GTW-930/GTW-940/GTW-941**

**3/8" / 1/2" / 1/2" DIGITAL TORQUE ADAPTER**

Accuracy : clockwise +/- 1.5% counterclockwise +/- 2.5%

10 pieces in one carton



**NEW PRODUCT**

**GTA-930/GTA-940/GTA-941**

**3/8" / 1/2" / 1/2" DIGITAL ANGLE TORQUE ADAPTER**

Accuracy : clockwise +/- 1.5% counterclockwise +/- 2.5%

10 pieces in one carton

| Item No.   | Drive | Gear | Torque Range |            | Indicator | Torque Adjusting | D    | H    | L    | Weight |
|------------|-------|------|--------------|------------|-----------|------------------|------|------|------|--------|
|            | Inch  | T    | Nm           | FT-LB      | LCD       | Digital          | mm   | mm   | mm   | kg     |
| GTW-201030 | 1/4"  | 24   | 1.5-30       | 1.11-22.13 | LCD       | Digital          | 38   | 38   | 410  | 0.71   |
| GTW-306135 | 3/8"  | 24   | 6.8-135      | 5.0-99.6   | LCD       | Digital          | 38   | 38   | 432  | 0.84   |
| GTW-406135 | 1/2"  | 24   | 6.8-135      | 5.0-99.6   | LCD       | Digital          | 38   | 41   | 455  | 1.07   |
| GTW-410200 | 1/2"  | 24   | 10-200       | 20.7-154.9 | LCD       | Digital          | 38   | 41   | 566  | 1.2    |
| GTW-417340 | 1/2"  | 24   | 17-340       | 12.5-250.8 | LCD       | Digital          | 38   | 41   | 662  | 1.4    |
| GTW-606060 | 3/4"  | 24   | 60-600       | 44.3-442.5 | LCD       | Digital          | 63   | 58   | 943  | 3.8    |
| GTW-610100 | 3/4"  | 24   | 100-1000     | 73.8-737.6 | LCD       | Digital          | 63   | 58   | 1235 | 4.6    |
| GTW-810100 | 1"    | 24   | 100-1000     | 73.8-737.6 | LCD       | Digital          | 69.5 | 70   | 1235 | 4.9    |
| GTW-930    | 3/8"  | ---  | 6.8-135      | 5.0-99.6   | LCD       | Digital          | 32   | 31.8 | 361  | 0.77   |
| GTW-940    | 1/2"  | ---  | 10-200       | 7.4-147.5  | LCD       | Digital          | 32   | 31.8 | 361  | 0.77   |
| GTW-941    | 1/2"  | ---  | 17-340       | 12.5-250.8 | LCD       | Digital          | 32   | 31.8 | 361  | 0.77   |
| GTA-930    | 3/8"  | ---  | 6.8-135      | 5.0-99.6   | LCD       | Digital          | 32   | 31.8 | 361  | 0.77   |
| GTA-940    | 1/2"  | ---  | 10-200       | 7.4-147.5  | LCD       | Digital          | 32   | 31.8 | 361  | 0.77   |
| GTA-941    | 1/2"  | ---  | 17-340       | 12.5-250.8 | LCD       | Digital          | 32   | 31.8 | 361  | 0.77   |

# IMPACT SOCKET

## MA4550M50

### TWIST SOCKET SET

5PCS 1/2" Drive (50mm Length)

- Contents : 17mm, 19mm, 21mm, 22mm  
Punch Bar / 12-80L

20 pieces in one carton



TWIST



## MB35012S

### IMPACT SOCKET SET

12pcs 3/8" Drive Inch Size Deep

- Contents : 5/16", 3/8", 7/16", 1/2", 9/16", 5/8",  
11/16", 3/4", 13/16", 7/8", 15/16", 1"

8 pieces in one carton



## MB34012S

### IMPACT SOCKET SET

12pcs 3/8" Drive Inch Size

- Contents : 5/16", 3/8", 7/16", 1/2", 9/16", 5/8",  
11/16", 3/4", 13/16", 7/8", 15/16", 1"

12 pieces in one carton



## MB34013M

### IMPACT SOCKET SET

13pcs 3/8" Drive Metric Size

- Contents : 6mm, 8mm, 9mm, 10mm, 11mm, 12mm,  
13mm, 14mm, 15mm, 16mm, 17mm, 18mm, 19mm

12 pieces in one carton



## MB35013M

### DEEP IMPACT SOCKET SET

13pcs 3/8" Drive Metric Size

- Contents : 6mm, 8mm, 9mm, 10mm, 11mm, 12mm,  
13mm, 14mm, 15mm, 16mm, 17mm, 18mm, 19mm

8 pieces in one carton



## MB43015M

### DEEP IMPACT SOCKET SET

15pcs 1/2" Drive Metric Size

- Contents : 10mm, 11mm, 12mm, 13mm, 14mm,  
15mm, 16mm, 17mm, 19mm, 21mm, 22mm,  
24mm, 27mm, 30mm, 32mm

6 pieces in one carton



## MB44008M

### IMPACT HEX DRIVE SET

8pcs 1/2" Drive Metric Size SAE (Length 78mm)

- Contents : H6, H7, H8, H10, H12, H14, H17, H19

12 pieces in one carton



## MB44008S

### IMPACT HEX DRIVE SET

8pcs 1/2" Drive Inch Size SAE (Length 78mm)

- Contents : 1/4", 5/16", 3/8", 7/16", 1/2", 9/16", 5/8", 3/4"

12 pieces in one carton



## MB44013S

### IMPACT SOCKET SET

13pcs 1/2" Drive Inch Size

- Contents : 7/16", 1/2", 9/16", 5/8", 11/16", 3/4",  
13/16", 7/8", 15/16", 1", 1-1/16", 1-1/8", 1-1/4"

6 pieces in one carton



## MB44014M

### IMPACT SOCKET SET

14pcs 1/2" Drive Metric Size

- Contents : 10mm, 11mm, 12mm, 13mm,  
14mm, 15mm, 16mm, 17mm, 18mm, 19mm,  
21mm, 22mm, 26mm, 27mm

8 pieces in one carton



## MB45010M

### DEEP IMPACT SOCKET SET

10pcs 1/2" Drive Metric Size

- Contents : 10mm, 12mm, 13mm, 14mm,  
15mm, 17mm, 19mm, 21mm, 24mm, 27mm

6 pieces in one carton



## MB45013S

### DEEP IMPACT SOCKET SET

13pcs 1/2" Drive Inch Size

- Contents : 7/16", 1/2", 9/16", 5/8", 11/16", 3/4",  
13/16", 7/8", 15/16", 1", 1-1/16", 1-1/8", 1-1/4"

4 pieces in one carton



## MB45014M

### DEEP IMPACT SOCKET SET

14pcs 1/2" Drive Metric Size

- Contents : 10mm, 11mm, 12mm, 13mm, 14mm, 15mm, 16mm, 17mm, 18mm, 19mm, 21mm, 22mm, 26mm, 27mm

4 pieces in one carton



## MB46008R

### STAR BIT SOCKET SET

8pcs 1/2" Drive

- Contents : T30, T40, T45, T47, T50, T55, T60, T70

10 pieces in one carton



## MB46010R

### STAR BIT SOCKET SET

10pcs 1/2" Drive

- Contents : T20, T25, T27, T30, T40, T45, T50, T55, T60, T70

8 pieces in one carton



## MB64008M

### IMPACT SOCKET SET

8pcs 3/4" Drive Metric Size

- Contents : 26mm, 27mm, 29mm, 30mm, 32mm, 33mm, 35mm, 36mm

4 pieces in one carton



## MB64008M1

### IMPACT SOCKET SET

8PCS 3/4" Drive

- Contents : 21mm, 23mm, 24mm, 27mm, 30mm, 32mm, 36mm, 41mm

6 pieces in one carton



## MB64008S

### IMPACT SOCKET SET

8pcs 3/4" Drive Inch Size

- Contents : 1", 1-5/16", 1-1/16", 1-3/8", 1-1/8", 1-7/16", 1-1/4", 1-1/2"

4 pieces in one carton



## MB64008SP

### IMPACT SOCKET SET

8pcs 3/4" Drive Inch Size

- Contents : 3/4", 7/8", 15/16", 1-1/16", 1-3/16", 1-1/4", 1-7/16", 1-1/2"

4 pieces in one carton



## MB65008M

### DEEP IMPACT SOCKET SET

8pcs 3/4" Drive Metric Size

- Contents : 26mm, 27mm, 29mm, 30mm, 32mm, 33mm, 35mm, 36mm

4 pieces in one carton



## MB65008M1

### DEEP IMPACT SOCKET SET

8pcs 3/4" Drive Metric Size

- Contents : 21mm, 23mm, 24mm, 27mm, 30mm, 32mm, 36mm, 41mm

4 pieces in one carton



## MB65008S

### DEEP IMPACT SOCKET SET

8pcs 3/4" Drive Inch Size

- Contents : 1", 1-1/16", 1-1/8", 1-1/4", 1-5/16", 1-3/8", 1-7/16", 1-1/2"

2 pieces in one carton



## MB65008S1

### DEEP IMPACT SOCKET SET

8pcs 3/4" Drive Inch Size

- Contents : 3/4", 7/8", 15/16", 1", 1-1/16", 1-1/8", 1-3/16", 1-1/4"

2 pieces in one carton



## MB66006S MB66006M

### IMPACT HEX DRIVE SET

6pcs 3/4" SAE 100mm Length

- Contents :
  - S : 1/2", 9/16", 5/8", 3/4", 7/8", 1"
  - M : H12, H14, H17, H19, H22, H24

5 pieces in one carton



# IMPACT SOCKET

## ME011N IMPACT ADAPTER IMPACT UNIVERSAL JOINT

6 pieces in one carton

- IMPACT ADAPTER
- Contents : 1/4"Fx3/8"M, 3/8"Fx1/4"M, 3/8"Fx1/2"M, 1/2"Fx3/8"M, 1/2"Fx3/4"M, 3/4"Fx1/2"M, 3/4"Fx1"M, 1"Fx3/4"M
- IMPACT UNIVERSAL JOINT
- Contents : 1/4"Dr, 3/8"Dr, 1/2"Dr



## MA4030 DEEP IMPACT SOCKET SET

3pcs 1/2" Drive  
24 pieces in one carton

- Contents : 17mm, 19mm, 21mm By identifying the different color coated, the operator can easily pick up the size needed.
- With the external sheath, the working object can be well protected from being rubbed, scratched, impacted...etc. With the 85mm extra long socket, to loosen or tighten bolt or nut in deeper hole become easier and convenient.

• Note : Impact socket for aluminum rim wheel nuts, with polymeric material insets.



## MA42006M IMPACT SOCKET SET

1/2" Drive Stubby Metric Size  
24 pieces in one carton



## MA42006S IMPACT SOCKET SET

1/2" Drive Stubby Metric Size  
24 pieces in one carton



## MA42015M IMPACT SOCKET SET

15pcs 1/2" Drive Stubby Metric Size  
12 pieces in one carton



## MA8050 WHEEL IMPACT SOCKET SET

5pcs 1" Drive Combination Budd  
4 pieces in one carton

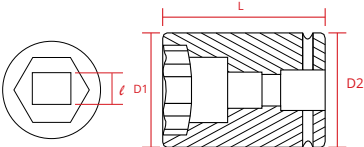

## MA42026 STUBBY METRIC IMPACT SOCKET SET

26pcs 1/2" Drive  
10 pieces in one carton

- Contents :
- S : 5/16", 3/8", 7/16", 1/2", 9/16", 5/8", 11/16", 3/4", 13/16", 7/8", 15/16"
- M : 10mm, 11mm, 12mm, 13mm, 14mm, 15mm, 16mm, 17mm, 18mm, 19mm, 20mm, 21mm, 22mm, 23mm, 24mm



## MA4031M85 DEEP THIN WALL IMPACT SOCKET SET

3pcs 1/2" Drive  
20 pieces in one carton

**STRENGTHEN  
STEEL  
SLEEVE**



• 3PCS 17mm, 19mm, 21mm

| M7 NO.   | Ø  | D1 | D2 | ℓ  | L  | ⚖   |
|----------|----|----|----|----|----|-----|
|          | mm | mm | mm | mm | mm | g   |
| MA401M13 | 13 | 20 | 25 | 5  | 28 | 54  |
| MA401M17 | 17 | 26 | 26 | 8  | 28 | 70  |
| MA401M19 | 19 | 28 | 28 | 9  | 28 | 80  |
| MA401M21 | 21 | 30 | 30 | 9  | 28 | 90  |
| MA401M22 | 22 | 32 | 30 | 9  | 28 | 100 |
| MA401M24 | 24 | 34 | 30 | 9  | 28 | 110 |

| M7 NO.   | Ø      | D1 | D2 | ℓ  | L  | ⚖   |
|----------|--------|----|----|----|----|-----|
|          | mm     | mm | mm | mm | mm | g   |
| MA401S16 | 1/2"   | 20 | 25 | 5  | 28 | 51  |
| MA401S18 | 9/16"  | 22 | 25 | 5  | 28 | 54  |
| MA401S20 | 5/8"   | 25 | 25 | 8  | 28 | 61  |
| MA401S22 | 11/16" | 26 | 25 | 8  | 28 | 90  |
| MA401S24 | 3/4"   | 28 | 30 | 9  | 28 | 100 |
| MA401S28 | 7/8"   | 32 | 30 | 9  | 28 | 95  |

| M7 NO.   | Ø  | D1 | D2 | T  | L  | ⚖   |
|----------|----|----|----|----|----|-----|
|          | mm | mm | mm | mm | mm | g   |
| MA401M10 | 10 | 18 | 25 | 5  | 28 | 50  |
| MA401M11 | 11 | 18 | 25 | 5  | 28 | 50  |
| MA401M12 | 12 | 19 | 25 | 5  | 28 | 50  |
| MA401M13 | 13 | 20 | 25 | 5  | 28 | 52  |
| MA401M14 | 14 | 22 | 25 | 5  | 28 | 53  |
| MA401M15 | 15 | 23 | 25 | 5  | 28 | 55  |
| MA401M16 | 16 | 25 | 25 | 8  | 28 | 62  |
| MA401M17 | 17 | 26 | 26 | 8  | 28 | 67  |
| MA401M18 | 18 | 28 | 28 | 8  | 28 | 82  |
| MA401M19 | 19 | 28 | 28 | 9  | 28 | 75  |
| MA401M20 | 20 | 30 | 30 | 9  | 28 | 90  |
| MA401M21 | 21 | 30 | 30 | 9  | 28 | 86  |
| MA401M22 | 22 | 32 | 30 | 9  | 28 | 94  |
| MA401M23 | 23 | 34 | 30 | 9  | 28 | 102 |
| MA401M24 | 24 | 34 | 30 | 9  | 28 | 98  |

| M7 NO.     | Ø      | D1  | D2  | ℓ      | L   | ⚖    |
|------------|--------|-----|-----|--------|-----|------|
|            | mm     | mm  | mm  | mm     | mm  | g    |
| MA812S4826 | 1-1/2" | 57  | 57  | 13/16" | 99  | 1.34 |
| MA812M3517 | 35     | 52  | 54  | 17     | 94  | 1.10 |
| MA812M3820 | 38     | 54  | 56  | 20     | 96  | 1.18 |
| MA812M4121 | 41     | 54  | 58  | 21     | 99  | 1.19 |
| MA831M33L  | 33     | 52  | 52  | ---    | 90  | 1.01 |
| MA8050     | ---    | --- | --- | ---    | --- | 6.20 |

## MB42011M

### STD IMPACT SOCKET SET

11pcs 1/2" Drive Metric size

- Contents : 10mm, 11mm, 13mm, 17mm, 19mm, 22mm, 24mm, 27mm, 29mm, 30mm, 32mm
- 6 pieces in one carton



## MA42011S

### STD IMPACT SOCKET SET

11pcs 1/2" Drive

- Contents : 5/16", 3/8", 7/16", 1/2", 9/16", 5/8", 11/16", 3/4", 13/16", 7/8", 15/16"
- 10 pieces in one carton



## NEW PRODUCT

## MB47010M

### IMPACT HEX BALL BIT SOCKET SET

10pcs 1/2" Drive

- Contents : H6, H7, H8, H10, H12, H14, H15, H17, H18, H19
  - Note : Not suitable for use with high power impact wrenches.
- 8 pieces in one carton



## MB61008M

### IMPACT SOCKET SET

8pcs 3/4" Drive

- Contents : M21, M22, M23, M24, M27, M30, M32, M36, M41
- 4 pieces in one carton



## MB61016M

### STD IMPACT SOCKET SET

16pcs 3/4" Drive

- Contents : M19, M21, M22, M24, M27, M28, M29, M30, M32, M33, M35, M36, M38, M41, M46, M50
- 2 pieces in one carton



## MB63008S

### IMPACT SOCKET SET

8pcs 3/4" Drive Inch Size

- Contents : 1-1/16", 1-1/8", 1-1/4", 1-5/16", 1-3/8", 1-7/16", 1-1/2"
- 3 pieces in one carton



## MB63008M

### DEEP IMPACT SOCKET SET

8pcs 3/4" Drive

- Contents : M21, M22, M24, M27, M30, M32, M36, M41
- 3 pieces in one carton



## MB67006M

### IMPACT HEX BALL BIT SOCKET SET

6pcs 3/4" Drive

- Contents : H14, H17, H19, H21, H24, H27
  - Note : Not suitable for use with high power impact wrenches.
- 6 pieces in one carton



## MB81009M

### STD SOCKET SET

9pcs 1" Drive

- Contents : 27mm, 30mm, 32mm, 35mm, 36mm, 38mm, 41mm, 46mm, 50mm
- 2 pieces in one carton



## MB85008M

### DEEP SOCKET SET

8pcs 1" Drive

- Contents : 27mm, 30mm, 32mm, 36mm, 38mm, 41mm, 46mm, 50mm
- 2 pieces in one carton



# IMPACT SOCKET

**PROVIDE FULL RANGE  
ALL SERIES HANG TAG.**



**IMPACT SOCKET**



**MALE ADAPTER**



**IMPACT DEEP SOCKET**



**UNIVERSAL JOINT**



**IMPACT HEX BIT**



**EXTENSION BAR**

## 1/4" MA211M IMPACT STANDARD SOCKET SET

- 1/4" Drive Standard Length
- 6 Points
- Metric Size

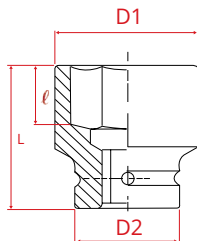

## 1/4" MA211S IMPACT STANDARD SOCKET

- 1/4" Drive Standard Length
- 6 Points
- Inch Size

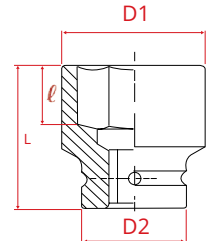

| M7 NO.   | ⌀  | D1   | D2   | ℓ  | L  | ⚖  | 📦  |
|----------|----|------|------|----|----|----|----|
|          | mm | mm   | mm   | mm | mm | g  |    |
| MA211M04 | 4  | 7.5  | 13.0 | 5  | 23 | 16 | 50 |
| MA211M05 | 5  | 8.7  | 13.0 | 6  | 23 | 16 | 50 |
| MA211M06 | 6  | 9.9  | 13.0 | 8  | 23 | 15 | 50 |
| MA211M07 | 7  | 11.1 | 13.0 | 8  | 23 | 14 | 50 |
| MA211M08 | 8  | 12.3 | 13.0 | 8  | 23 | 14 | 50 |
| MA211M09 | 9  | 13.8 | 13.0 | 8  | 23 | 14 | 50 |
| MA211M10 | 10 | 14.5 | 13.0 | 8  | 23 | 15 | 50 |
| MA211M11 | 11 | 16.0 | 13.0 | 8  | 23 | 17 | 50 |
| MA211M12 | 12 | 17.0 | 13.0 | 8  | 23 | 17 | 50 |
| MA211M13 | 13 | 18.8 | 13.0 | 8  | 23 | 20 | 50 |
| MA211M14 | 14 | 20.0 | 13.0 | 8  | 23 | 21 | 50 |

| M7 NO.   | ⌀      | D1   | D2   | ℓ  | L  | ⚖  | 📦  |
|----------|--------|------|------|----|----|----|----|
|          | inch   | mm   | mm   | mm | mm | g  |    |
| MA211S06 | 3/16"  | 8.4  | 13.0 | 6  | 23 | 15 | 50 |
| MA211S07 | 7/32"  | 9.4  | 13.0 | 6  | 23 | 16 | 50 |
| MA211S08 | 1/4"   | 10.3 | 13.0 | 8  | 23 | 15 | 50 |
| MA211S09 | 9/32"  | 11.3 | 13.0 | 8  | 23 | 15 | 50 |
| MA211S10 | 5/16"  | 12.3 | 13.0 | 8  | 23 | 14 | 50 |
| MA211S11 | 11/32" | 13.8 | 13.0 | 8  | 23 | 14 | 50 |
| MA211S12 | 3/8"   | 14.5 | 13.0 | 8  | 23 | 15 | 50 |
| MA211S14 | 7/16"  | 16.0 | 13.0 | 8  | 23 | 16 | 50 |
| MA211S16 | 1/2"   | 18.8 | 13.0 | 8  | 23 | 19 | 50 |
| MA211S18 | 9/16"  | 19.8 | 13.0 | 8  | 23 | 21 | 50 |

# 1/4" MA231M

## IMPACT DEEP SOCKET

- 1/4" Drive Deep Length
- 6 Points
- Metric Size

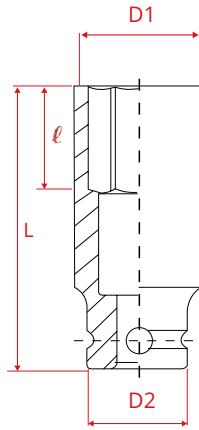

| M7 NO.   | ⊘  | D1   | D2   | l  | L  | ⚖  | 📦  |
|----------|----|------|------|----|----|----|----|
|          | mm | mm   | mm   | mm | mm | g  |    |
| MA231M04 | 4  | 7.5  | 13.0 | 7  | 50 | 28 | 50 |
| MA231M05 | 5  | 8.7  | 13.0 | 9  | 50 | 29 | 50 |
| MA231M06 | 6  | 9.9  | 13.0 | 11 | 50 | 31 | 50 |
| MA231M07 | 7  | 11.1 | 13.0 | 11 | 50 | 31 | 50 |
| MA231M08 | 8  | 12.3 | 13.0 | 13 | 50 | 31 | 50 |
| MA231M09 | 9  | 13.8 | 13.0 | 13 | 50 | 37 | 50 |
| MA231M10 | 10 | 14.5 | 13.0 | 13 | 50 | 37 | 50 |
| MA231M11 | 11 | 16.0 | 13.0 | 13 | 50 | 41 | 50 |
| MA231M12 | 12 | 17.0 | 13.0 | 13 | 50 | 43 | 50 |
| MA231M13 | 13 | 18.8 | 13.0 | 13 | 50 | 58 | 50 |
| MA231M14 | 14 | 20.0 | 13.0 | 13 | 50 | 60 | 50 |

# 1/4" MA231S

## IMPACT DEEP SOCKET

- 1/4" Drive Deep Length
- 6 Points
- Inch Size

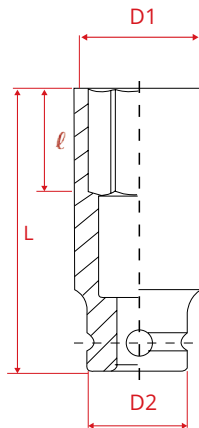

| M7 NO.   | ⊘      | D1   | D2   | l  | L  | ⚖  | 📦  |
|----------|--------|------|------|----|----|----|----|
|          | inch   | mm   | mm   | mm | mm | g  |    |
| MA231S06 | 3/16"  | 8.4  | 13.0 | 9  | 50 | 29 | 50 |
| MA231S07 | 7/32"  | 9.4  | 13.0 | 9  | 50 | 30 | 50 |
| MA231S08 | 1/4"   | 10.3 | 13.0 | 11 | 50 | 31 | 50 |
| MA231S09 | 9/32"  | 11.3 | 13.0 | 11 | 50 | 32 | 50 |
| MA231S10 | 5/16"  | 12.3 | 13.0 | 13 | 50 | 32 | 50 |
| MA231S11 | 11/32" | 13.8 | 13.0 | 13 | 50 | 37 | 50 |
| MA231S12 | 3/8"   | 14.5 | 13.0 | 13 | 50 | 41 | 50 |
| MA231S14 | 7/16"  | 16.0 | 13.0 | 13 | 50 | 41 | 50 |
| MA231S16 | 1/2"   | 18.8 | 13.0 | 13 | 50 | 56 | 50 |
| MA231S18 | 9/16"  | 19.8 | 13.0 | 13 | 50 | 61 | 50 |

# 3/8" MA311M

## IMPACT STANDARD SOCKET

- 3/8" Drive Standard Length
- 6 Points
- Metric Size

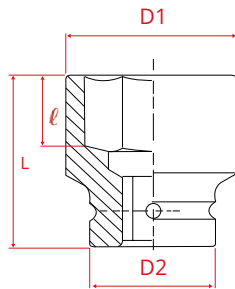

| M7 NO.   | ⊘  | D1   | D2   | l  | L    | ⚖  | 📦  |
|----------|----|------|------|----|------|----|----|
|          | mm | mm   | mm   | mm | mm   | g  |    |
| MA311M06 | 6  | 10.0 | 19.0 | 9  | 29.5 | 31 | 50 |
| MA311M07 | 7  | 11.4 | 19.0 | 9  | 29.5 | 31 | 50 |
| MA311M08 | 8  | 12.7 | 19.0 | 9  | 29.5 | 31 | 50 |
| MA311M09 | 9  | 14.0 | 19.0 | 10 | 29.5 | 33 | 50 |
| MA311M10 | 10 | 15.2 | 19.0 | 10 | 29.5 | 33 | 50 |
| MA311M11 | 11 | 17.0 | 19.0 | 11 | 29.5 | 34 | 50 |
| MA311M12 | 12 | 18.0 | 19.0 | 11 | 29.5 | 35 | 50 |
| MA311M13 | 13 | 19.0 | 19.0 | 11 | 29.5 | 36 | 50 |
| MA311M14 | 14 | 20.0 | 19.0 | 11 | 29.5 | 37 | 50 |
| MA311M15 | 15 | 21.9 | 19.0 | 13 | 29.5 | 42 | 50 |
| MA311M16 | 16 | 23.5 | 22.0 | 13 | 30.0 | 57 | 50 |
| MA311M17 | 17 | 25.0 | 22.0 | 13 | 30.0 | 59 | 50 |
| MA311M18 | 18 | 26.0 | 22.0 | 13 | 30.0 | 61 | 50 |
| MA311M19 | 19 | 27.0 | 22.0 | 15 | 30.0 | 63 | 50 |
| MA311M20 | 20 | 28.0 | 22.0 | 15 | 30.0 | 79 | 50 |
| MA311M21 | 21 | 30.0 | 22.0 | 15 | 30.0 | 79 | 50 |
| MA311M22 | 22 | 32.0 | 22.0 | 15 | 30.0 | 98 | 50 |
| MA311M23 | 23 | 33.0 | 22.0 | 15 | 30.0 | 98 | 50 |
| MA311M24 | 24 | 34.0 | 22.0 | 15 | 30.0 | 98 | 50 |

# 3/8" MA311S

## IMPACT STANDARD SOCKET

- 3/8" Drive Standard Length
- 6 Points
- Inch Size

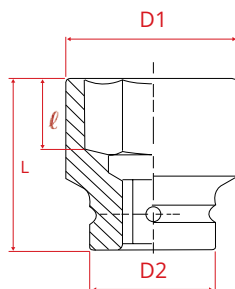

| M7 NO.   | ⊘      | D1   | D2   | l    | L    | ⚖   | 📦  |
|----------|--------|------|------|------|------|-----|----|
|          | inch   | mm   | mm   | mm   | mm   | g   |    |
| MA311S10 | 5/16"  | 12.6 | 19.0 | 9.0  | 29.5 | 31  | 50 |
| MA311S12 | 3/8"   | 14.6 | 19.0 | 10.0 | 29.5 | 33  | 50 |
| MA311S14 | 7/16"  | 17.1 | 19.0 | 11.0 | 29.5 | 33  | 50 |
| MA311S16 | 1/2"   | 19.0 | 19.0 | 11.0 | 29.5 | 37  | 50 |
| MA311S18 | 9/16"  | 20.0 | 19.0 | 11.0 | 29.5 | 39  | 50 |
| MA311S20 | 5/8"   | 23.5 | 22.0 | 13.0 | 30.0 | 54  | 50 |
| MA311S22 | 11/16" | 25.0 | 22.0 | 13.0 | 30.0 | 56  | 50 |
| MA311S24 | 3/4"   | 27.0 | 22.0 | 15.0 | 30.0 | 63  | 50 |
| MA311S26 | 13/16" | 30.0 | 22.0 | 15.0 | 30.0 | 79  | 50 |
| MA311S28 | 7/8"   | 32.0 | 22.0 | 15.0 | 30.0 | 87  | 50 |
| MA311S30 | 15/16" | 34.0 | 22.0 | 15.0 | 30.0 | 98  | 50 |
| MA311S32 | 1"     | 36.0 | 22.0 | 15.0 | 30.0 | 100 | 50 |



# IMPACT SOCKET

## 3/8" MA331M IMPACT DEEP SOCKET

- 3/8" Drive Deep Length
- 6 Points
- Metric Size

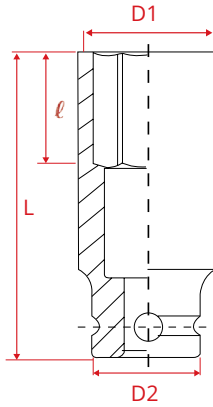

| M7 NO.   | ⊘  | D1   | D2   | ℓ  | L  | ⚖   | 📦  |
|----------|----|------|------|----|----|-----|----|
|          | mm | mm   | mm   | mm | mm | g   |    |
| MA331M06 | 6  | 10.1 | 19.0 | 14 | 63 | 73  | 50 |
| MA331M07 | 7  | 11.4 | 19.0 | 14 | 63 | 73  | 50 |
| MA331M08 | 8  | 12.7 | 19.0 | 14 | 63 | 73  | 50 |
| MA331M09 | 9  | 14.0 | 19.0 | 14 | 63 | 75  | 50 |
| MA331M10 | 10 | 15.2 | 19.0 | 20 | 63 | 76  | 50 |
| MA331M11 | 11 | 17.0 | 19.0 | 20 | 63 | 81  | 50 |
| MA331M12 | 12 | 18.0 | 19.0 | 22 | 63 | 78  | 50 |
| MA331M13 | 13 | 19.0 | 19.0 | 24 | 63 | 86  | 50 |
| MA331M14 | 14 | 20.0 | 19.0 | 26 | 63 | 93  | 50 |
| MA331M15 | 15 | 22.2 | 19.0 | 27 | 63 | 102 | 50 |
| MA331M16 | 16 | 23.5 | 22.0 | 26 | 63 | 115 | 50 |
| MA331M17 | 17 | 25.0 | 22.0 | 26 | 63 | 127 | 50 |
| MA331M18 | 18 | 26.0 | 22.0 | 26 | 63 | 137 | 50 |
| MA331M19 | 19 | 27.0 | 22.0 | 26 | 63 | 143 | 50 |
| MA331M20 | 20 | 28.0 | 22.0 | 26 | 63 | 143 | 50 |
| MA331M21 | 21 | 30.0 | 22.0 | 26 | 63 | 194 | 50 |
| MA331M22 | 22 | 32.0 | 22.0 | 26 | 63 | 206 | 50 |
| MA331M23 | 23 | 33.0 | 22.0 | 26 | 63 | 206 | 50 |

## 3/8" MA331S IMPACT DEEP SOCKET

- 3/8" Drive Deep Length
- 6 Points
- Inch Size

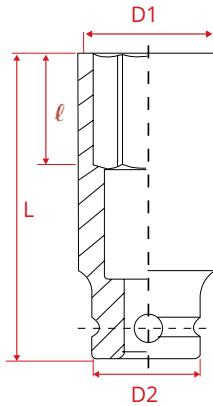

| M7 NO.   | ⊘      | D1   | D2   | ℓ   | L    | ⚖   | 📦  |
|----------|--------|------|------|-----|------|-----|----|
|          | inch   | mm   | mm   | mm  | mm   | g   |    |
| MA331S08 | 1/4"   | 10.5 | 19.0 | 4.0 | 28.5 | 35  | 50 |
| MA331S10 | 5/16"  | 12.6 | 19.0 | 14  | 63   | 73  | 50 |
| MA331S12 | 3/8"   | 14.6 | 19.0 | 20  | 63   | 76  | 50 |
| MA331S14 | 7/16"  | 17.1 | 19.0 | 20  | 63   | 81  | 50 |
| MA331S16 | 1/2"   | 19.0 | 19.0 | 24  | 63   | 83  | 50 |
| MA331S18 | 9/16"  | 20.0 | 19.0 | 26  | 63   | 87  | 50 |
| MA331S20 | 5/8"   | 23.5 | 22.0 | 26  | 63   | 111 | 50 |
| MA331S22 | 11/16" | 25.0 | 22.0 | 26  | 63   | 125 | 50 |
| MA331S24 | 3/4"   | 27.0 | 22.0 | 26  | 63   | 142 | 50 |
| MA331S26 | 13/16" | 30.0 | 22.0 | 26  | 63   | 178 | 50 |
| MA331S28 | 7/8"   | 32.0 | 22.0 | 26  | 63   | 188 | 50 |
| MA331S30 | 15/16" | 34.0 | 22.0 | 26  | 63   | 232 | 50 |
| MA331S32 | 1"     | 36.0 | 22.0 | 26  | 63   | 249 | 50 |

## MA401M IMPACT SOCKET

- 1/2" Drive Stubby Metric Size

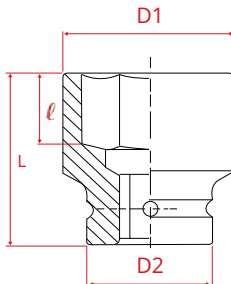

| M7 NO.   | ⊘  | D1 | D2 | ℓ  | L  | ⚖   | 📦   |
|----------|----|----|----|----|----|-----|-----|
|          | mm | mm | mm | mm | mm | g   |     |
| MA401M09 | 9  | 18 | 25 | 5  | 28 | 48  | 100 |
| MA401M10 | 10 | 18 | 25 | 5  | 28 | 50  | 100 |
| MA401M11 | 11 | 18 | 25 | 5  | 28 | 50  | 100 |
| MA401M12 | 12 | 19 | 25 | 5  | 28 | 50  | 100 |
| MA401M13 | 13 | 20 | 25 | 5  | 28 | 52  | 100 |
| MA401M14 | 14 | 22 | 25 | 5  | 28 | 53  | 100 |
| MA401M15 | 15 | 23 | 25 | 5  | 28 | 55  | 100 |
| MA401M16 | 16 | 25 | 25 | 8  | 28 | 62  | 100 |
| MA401M17 | 17 | 26 | 26 | 8  | 28 | 67  | 100 |
| MA401M18 | 18 | 28 | 28 | 8  | 28 | 82  | 100 |
| MA401M19 | 19 | 28 | 28 | 9  | 28 | 80  | 100 |
| MA401M20 | 20 | 30 | 30 | 9  | 28 | 90  | 100 |
| MA401M21 | 21 | 30 | 30 | 9  | 28 | 86  | 100 |
| MA401M22 | 22 | 32 | 30 | 9  | 28 | 94  | 100 |
| MA401M23 | 23 | 34 | 30 | 9  | 28 | 102 | 100 |
| MA401M24 | 24 | 34 | 30 | 9  | 28 | 98  | 100 |

## MA401S IMPACT SOCKET

- 1/2" Drive Stubby Inch Size

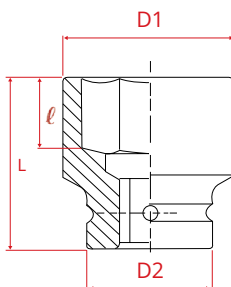

| M7 NO.   | ⊘      | D1   | D2 | ℓ  | L  | ⚖  | 📦   |
|----------|--------|------|----|----|----|----|-----|
|          | inch   | mm   | mm | mm | mm | g  |     |
| MA401S10 | 5/16"  | 14.5 | 25 | 5  | 28 | 46 | 100 |
| MA401S12 | 3/8"   | 16   | 25 | 5  | 28 | 47 | 100 |
| MA401S14 | 7/16"  | 18   | 25 | 5  | 28 | 50 | 100 |
| MA401S16 | 1/2"   | 20   | 25 | 5  | 28 | 51 | 100 |
| MA401S18 | 9/16"  | 22   | 25 | 5  | 28 | 54 | 100 |
| MA401S20 | 5/8"   | 25   | 25 | 8  | 28 | 61 | 100 |
| MA401S26 | 13/16" | 30   | 30 | 9  | 28 | 88 | 100 |
| MA401S28 | 7/8"   | 32   | 30 | 9  | 28 | 95 | 100 |
| MA401S30 | 15/16" | 34   | 30 | 9  | 28 | 98 | 100 |

# 1/2" MA411M

## IMPACT STANDARD SOCKET

- 1/2" Drive Standard Length
- 6 Points
- Metric Size

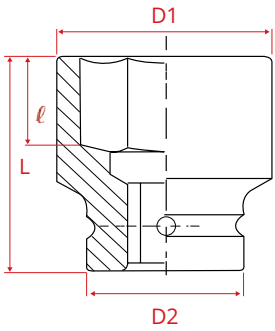

| M7 NO.   | ⊙  | D1   | D2   | ℓ    | L  | ⚖   | 📦  |
|----------|----|------|------|------|----|-----|----|
|          | mm | mm   | mm   | mm   | mm | g   |    |
| MA411M08 | 8  | 14.5 | 25.0 | 9    | 38 | 80  | 75 |
| MA411M09 | 9  | 15.6 | 25.0 | 10   | 38 | 80  | 75 |
| MA411M10 | 10 | 16.7 | 25.0 | 10   | 38 | 71  | 75 |
| MA411M11 | 11 | 18.0 | 25.0 | 10   | 38 | 72  | 75 |
| MA411M12 | 12 | 19.0 | 25.0 | 11   | 38 | 72  | 75 |
| MA411M13 | 13 | 20.2 | 25.0 | 11   | 38 | 74  | 75 |
| MA411M14 | 14 | 21.5 | 25.0 | 11   | 38 | 77  | 75 |
| MA411M15 | 15 | 23.0 | 25.0 | 12   | 38 | 78  | 75 |
| MA411M16 | 16 | 24.9 | 25.0 | 12   | 38 | 82  | 75 |
| MA411M17 | 17 | 25.9 | 25.0 | 13   | 38 | 84  | 75 |
| MA411M18 | 18 | 26.9 | 25.0 | 13   | 38 | 88  | 75 |
| MA411M19 | 19 | 29.9 | 25.0 | 13   | 38 | 88  | 50 |
| MA411M20 | 20 | 29.9 | 25.0 | 13   | 38 | 90  | 50 |
| MA411M21 | 21 | 32.0 | 30.0 | 14.5 | 38 | 93  | 50 |
| MA411M22 | 22 | 32.0 | 30.0 | 14.5 | 38 | 134 | 50 |
| MA411M23 | 23 | 34.0 | 30.0 | 16   | 42 | 138 | 20 |
| MA411M24 | 24 | 36.0 | 30.0 | 17   | 42 | 138 | 20 |
| MA411M25 | 25 | 36.0 | 30.0 | 17   | 42 | 150 | 20 |
| MA411M26 | 26 | 38.0 | 30.0 | 17   | 42 | 158 | 20 |
| MA411M27 | 27 | 40.0 | 30.0 | 19   | 46 | 159 | 20 |
| MA411M28 | 28 | 38.0 | 40.0 | 16   | 46 | 270 | 20 |
| MA411M29 | 29 | 38.0 | 40.0 | 16   | 46 | 270 | 20 |
| MA411M30 | 30 | 41.9 | 30.0 | 19   | 46 | 222 | 20 |
| MA411M31 | 31 | 43.9 | 30.0 | 20.5 | 46 | 244 | 20 |
| MA411M32 | 32 | 43.9 | 30.0 | 20.5 | 46 | 238 | 20 |
| MA411M33 | 33 | 45.9 | 35.0 | 22   | 46 | 290 | 20 |
| MA411M34 | 34 | 45.9 | 35.0 | 22   | 46 | 330 | 20 |
| MA411M35 | 35 | 49.9 | 35.0 | 22   | 50 | 357 | 20 |
| MA411M36 | 36 | 49.9 | 35.0 | 22   | 50 | 376 | 20 |
| MA411M37 | 37 | 50.9 | 35.0 | 25   | 50 | 380 | 20 |
| MA411M38 | 38 | 51.9 | 35.0 | 25   | 50 | 390 | 20 |

# 1/2" MA411S

## IMPACT STANDARD SOCKET

- 1/2" Drive Standard Length
- 6 Points
- Inch Size

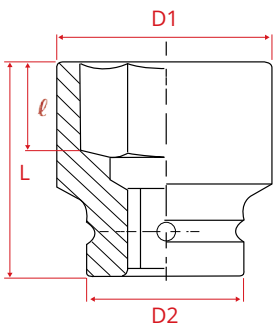

| M7 NO.   | ⊙       | D1   | D2   | ℓ    | L  | ⚖   | 📦  |
|----------|---------|------|------|------|----|-----|----|
|          | inch    | mm   | mm   | mm   | mm | g   |    |
| MA411S08 | 1/4"    | 12.5 | 25.0 | 8    | 38 | 70  | 40 |
| MA411S10 | 5/16"   | 14.5 | 25.0 | 8    | 38 | 70  | 40 |
| MA411S12 | 3/8"    | 16.0 | 25.0 | 8    | 38 | 70  | 40 |
| MA411S14 | 7/16"   | 18.0 | 25.0 | 9    | 38 | 72  | 40 |
| MA411S16 | 1/2"    | 20.0 | 25.0 | 11   | 38 | 74  | 40 |
| MA411S18 | 9/16"   | 22.0 | 25.0 | 11   | 38 | 76  | 40 |
| MA411S20 | 5/8"    | 24.9 | 25.0 | 12   | 38 | 81  | 40 |
| MA411S22 | 11/16"  | 26.0 | 25.0 | 12   | 38 | 83  | 40 |
| MA411S24 | 3/4"    | 28.0 | 25.0 | 12   | 38 | 85  | 40 |
| MA411S26 | 13/16"  | 30.0 | 25.0 | 13   | 38 | 94  | 40 |
| MA411S28 | 7/8"    | 32.0 | 30.0 | 13   | 38 | 134 | 40 |
| MA411S30 | 15/16"  | 34.0 | 30.0 | 15   | 38 | 135 | 40 |
| MA411S32 | 1"      | 36.0 | 30.0 | 15   | 38 | 144 | 40 |
| MA411S34 | 1-1/16" | 38.0 | 30.0 | 17   | 40 | 203 | 20 |
| MA411S36 | 1-1/8"  | 40.0 | 30.0 | 18.5 | 40 | 260 | 20 |
| MA411S38 | 1-3/16" | 42.0 | 30.0 | 18.5 | 40 | 280 | 20 |
| MA411S40 | 1-1/4"  | 44.0 | 30.0 | 18.5 | 40 | 290 | 20 |
| MA411S42 | 1-5/16" | 46.0 | 35.0 | 21   | 43 | 301 | 20 |
| MA411S44 | 1-3/8"  | 48.0 | 35.0 | 21   | 43 | 338 | 20 |
| MA411S46 | 1-7/16" | 50.0 | 44.0 | 21   | 43 | 357 | 20 |
| MA411S48 | 1-1/2"  | 52.0 | 44.0 | 23.5 | 43 | 376 | 20 |

# IMPACT SOCKET

## 1/2" MA431M IMPACT DEEP SOCKET

- 1/2" Drive Deep Length
- 6 Points
- Metric Size

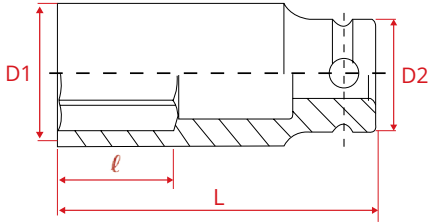

| M7 NO.   | ⊙  | D1   | D2   | ℓ  | L  | ⚖   | 📦  |
|----------|----|------|------|----|----|-----|----|
|          | mm | mm   | mm   | mm | mm | g   |    |
| MA431M06 | 6  | 12.0 | 25.0 | 10 | 82 | 168 | 50 |
| MA431M07 | 7  | 13.0 | 25.0 | 10 | 82 | 168 | 50 |
| MA431M08 | 8  | 14.5 | 25.0 | 13 | 82 | 168 | 50 |
| MA431M09 | 9  | 15.6 | 25.0 | 15 | 82 | 168 | 50 |
| MA431M10 | 10 | 16.7 | 25.0 | 15 | 82 | 168 | 50 |
| MA431M11 | 11 | 18.0 | 25.0 | 15 | 82 | 169 | 50 |
| MA431M12 | 12 | 19.0 | 25.0 | 15 | 82 | 170 | 50 |
| MA431M13 | 13 | 20.2 | 25.0 | 15 | 82 | 176 | 50 |
| MA431M14 | 14 | 21.5 | 25.0 | 18 | 82 | 180 | 50 |
| MA431M15 | 15 | 23.0 | 25.0 | 18 | 82 | 184 | 50 |
| MA431M16 | 16 | 24.9 | 25.0 | 18 | 82 | 190 | 50 |
| MA431M17 | 17 | 25.9 | 25.0 | 19 | 82 | 196 | 50 |
| MA431M18 | 18 | 26.9 | 25.0 | 19 | 82 | 214 | 50 |
| MA431M19 | 19 | 29.9 | 30.0 | 19 | 82 | 216 | 50 |
| MA431M20 | 20 | 29.9 | 30.0 | 26 | 82 | 220 | 50 |
| MA431M21 | 21 | 31.9 | 30.0 | 26 | 82 | 222 | 50 |
| MA431M22 | 22 | 31.9 | 30.0 | 26 | 82 | 288 | 50 |
| MA431M23 | 23 | 33.9 | 30.0 | 26 | 82 | 338 | 20 |
| MA431M24 | 24 | 35.9 | 30.0 | 26 | 82 | 377 | 20 |
| MA431M25 | 25 | 35.9 | 30.0 | 26 | 82 | 369 | 20 |
| MA431M26 | 26 | 37.9 | 30.0 | 26 | 82 | 321 | 20 |
| MA431M27 | 27 | 39.9 | 30.0 | 26 | 82 | 454 | 20 |
| MA431M28 | 28 | 39.9 | 30.0 | 26 | 82 | 442 | 20 |
| MA431M29 | 29 | 41.9 | 30.0 | 26 | 82 | 451 | 20 |
| MA431M30 | 30 | 41.9 | 30.0 | 26 | 82 | 431 | 20 |
| MA431M31 | 31 | 43.9 | 35.0 | 26 | 90 | 480 | 20 |
| MA431M32 | 32 | 43.9 | 35.0 | 26 | 90 | 497 | 20 |
| MA431M33 | 33 | 45.9 | 35.0 | 38 | 90 | 590 | 20 |
| MA431M34 | 34 | 45.9 | 35.0 | 38 | 90 | 554 | 20 |
| MA431M35 | 35 | 49.9 | 40.0 | 38 | 93 | 690 | 20 |
| MA431M36 | 36 | 49.9 | 40.0 | 38 | 93 | 670 | 20 |

## 1/2" MA431S IMPACT DEEP SOCKET

- 1/2" Drive Deep Length
- 6 Points
- Inch Size

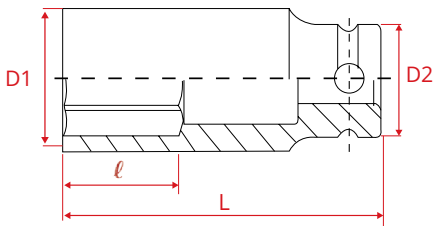

| M7 NO.   | ⊙       | D1   | D2   | ℓ  | L  | ⚖   | 📦  |
|----------|---------|------|------|----|----|-----|----|
|          | inch    | mm   | mm   | mm | mm | g   |    |
| MA431S08 | 1/4"    | 12.5 | 25.0 | 10 | 82 | 160 | 40 |
| MA431S10 | 5/16"   | 14.5 | 25.0 | 13 | 82 | 160 | 40 |
| MA431S12 | 3/8"    | 16.0 | 25.0 | 15 | 82 | 167 | 40 |
| MA431S14 | 7/16"   | 18.0 | 25.0 | 15 | 82 | 171 | 40 |
| MA431S16 | 1/2"    | 20.0 | 25.0 | 15 | 82 | 176 | 40 |
| MA431S18 | 9/16"   | 22.0 | 25.0 | 17 | 82 | 181 | 40 |
| MA431S20 | 5/8"    | 24.9 | 25.0 | 18 | 82 | 187 | 40 |
| MA431S22 | 11/16"  | 25.9 | 25.0 | 18 | 82 | 194 | 40 |
| MA431S24 | 3/4"    | 27.9 | 25.0 | 18 | 82 | 217 | 20 |
| MA431S26 | 13/16"  | 29.9 | 25.0 | 26 | 82 | 227 | 20 |
| MA431S28 | 7/8"    | 31.9 | 30.0 | 26 | 82 | 290 | 20 |
| MA431S30 | 15/16"  | 33.9 | 30.0 | 26 | 82 | 319 | 20 |
| MA431S32 | 1"      | 35.9 | 30.0 | 26 | 82 | 346 | 20 |
| MA431S34 | 1-1/16" | 37.9 | 30.0 | 26 | 82 | 450 | 20 |
| MA431S36 | 1-1/8"  | 39.9 | 30.0 | 26 | 82 | 450 | 20 |
| MA431S38 | 1-3/16" | 41.9 | 30.0 | 26 | 82 | 480 | 20 |
| MA431S40 | 1-1/4"  | 43.9 | 30.0 | 26 | 82 | 500 | 20 |
| MA431S42 | 1-5/16" | 45.9 | 35.0 | 34 | 90 | 565 | 20 |
| MA431S44 | 1-3/8"  | 47.9 | 35.0 | 34 | 90 | 595 | 20 |
| MA431S46 | 1-7/16" | 49.9 | 44.0 | 34 | 90 | 699 | 20 |
| MA431S48 | 1-1/2"  | 51.8 | 44.0 | 34 | 90 | 744 | 20 |

# 3/4" MA611S

## IMPACT STANDARD SOCKET

- 3/4" Drive Standard Length
- 6 Points
- Inch Size

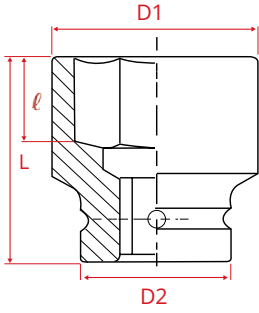

| M7 NO.   | ⊘        | D1   | D2 | ℓ    | L  | ⚖    | 📦  |
|----------|----------|------|----|------|----|------|----|
|          | inch     | mm   | mm | mm   | mm | g    |    |
| MA611S16 | 1/2"     | 22   | 38 | 6.3  | 50 | 380  | 50 |
| MA611S18 | 9/16"    | 25.5 | 38 | 6.3  | 50 | 380  | 50 |
| MA611S20 | 5/8"     | 27.5 | 38 | 7.1  | 50 | 380  | 50 |
| MA611S22 | 11/16"   | 29   | 38 | 8.1  | 50 | 390  | 50 |
| MA611S24 | 3/4"     | 30.2 | 38 | 9    | 52 | 390  | 50 |
| MA611S26 | 13/16"   | 32   | 38 | 10.6 | 52 | 400  | 50 |
| MA611S28 | 7/8"     | 34   | 38 | 12.2 | 52 | 440  | 50 |
| MA611S30 | 15/16"   | 36   | 38 | 12.4 | 52 | 440  | 50 |
| MA611S32 | 1"       | 38   | 38 | 12.4 | 52 | 450  | 50 |
| MA611S34 | 1-1/16"  | 40   | 40 | 12.4 | 52 | 510  | 50 |
| MA611S36 | 1-1/8"   | 42   | 42 | 16.1 | 52 | 570  | 50 |
| MA611S38 | 1-3/16"  | 44   | 44 | 16.1 | 52 | 610  | 35 |
| MA611S40 | 1-1/4"   | 46   | 44 | 16.1 | 52 | 630  | 35 |
| MA611S42 | 1-5/16"  | 50   | 44 | 18.8 | 56 | 660  | 35 |
| MA611S44 | 1-3/8"   | 52   | 44 | 18.8 | 56 | 770  | 35 |
| MA611S46 | 1-7/16"  | 54   | 44 | 18.8 | 56 | 770  | 35 |
| MA611S48 | 1-1/2"   | 56   | 44 | 21.5 | 56 | 830  | 25 |
| MA611S50 | 1-9/16"  | 58   | 44 | 21.5 | 58 | 860  | 25 |
| MA611S52 | 1-5/8"   | 60   | 44 | 21.5 | 58 | 870  | 25 |
| MA611S54 | 1-11/16" | 63.5 | 44 | 24.6 | 62 | 1050 | 25 |
| MA611S56 | 1-3/4"   | 65   | 44 | 24.9 | 62 | 1090 | 25 |
| MA611S58 | 1-13/16" | 67   | 44 | 25.1 | 63 | 1150 | 25 |
| MA611S60 | 1-7/8"   | 68   | 44 | 27   | 68 | 1200 | 25 |
| MA611S62 | 1-15/16" | 70   | 44 | 27   | 70 | 1250 | 25 |
| MA611S64 | 2"       | 71   | 44 | 27   | 72 | 1310 | 25 |
| MA611S66 | 2-1/16"  | 74   | 54 | 29.2 | 72 | 1380 | 25 |
| MA611S68 | 2-1/8"   | 77   | 54 | 30.3 | 72 | 1650 | 20 |
| MA611S70 | 2-3/16"  | 77   | 54 | 30.3 | 74 | 1700 | 20 |
| MA611S72 | 2-1/4"   | 80   | 54 | 32.4 | 74 | 1720 | 20 |
| MA611S74 | 2-5/16"  | 82   | 54 | 32.8 | 75 | 1810 | 20 |
| MA611S76 | 2-3/8"   | 84   | 54 | 33.1 | 80 | 2050 | 20 |
| MA611S78 | 2-7/16"  | 85   | 54 | 34.4 | 80 | 2080 | 10 |
| MA611S80 | 2-1/2"   | 86   | 54 | 34.4 | 80 | 2250 | 10 |
| MA611S82 | 2-9/16"  | 88   | 54 | 35.1 | 80 | 2300 | 5  |
| MA611S84 | 2-5/8"   | 88   | 54 | 35.1 | 80 | 2300 | 5  |
| MA611S86 | 2-11/16" | 88   | 54 | 36.4 | 80 | 2300 | 5  |
| MA611S88 | 2-3/4"   | 96   | 54 | 37.8 | 85 | 2450 | 5  |
| MA611S90 | 2-13/16" | 96   | 60 | 38.1 | 88 | 2550 | 5  |
| MA611S92 | 2-7/8"   | 98   | 60 | 39.4 | 90 | 2600 | 5  |
| MA611S94 | 2-15/16" | 100  | 60 | 46   | 92 | 2700 | 5  |
| MA611S96 | 3"       | 100  | 60 | 46   | 92 | 2800 | 5  |

# 3/4" MA611M

## IMPACT STANDARD SOCKET

- 3/4" Drive Standard Length
- 6 Points
- Metric Size

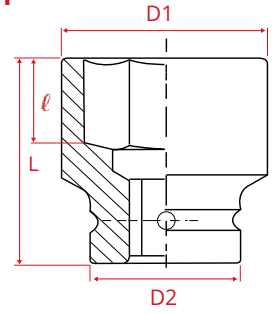

| M7 NO.   | ⊘  | D1   | D2 | ℓ    | L  | ⚖    | 📦  |
|----------|----|------|----|------|----|------|----|
|          | mm | mm   | mm | mm   | mm | g    |    |
| MA611M13 | 13 | 22   | 38 | 7    | 50 | 210  | 50 |
| MA611M14 | 14 | 25.5 | 38 | 7    | 50 | 210  | 50 |
| MA611M15 | 15 | 26   | 38 | 7    | 50 | 220  | 50 |
| MA611M16 | 16 | 27.5 | 38 | 7    | 50 | 220  | 50 |
| MA611M17 | 17 | 28.5 | 38 | 9.6  | 50 | 230  | 50 |
| MA611M18 | 18 | 29.5 | 38 | 10.2 | 52 | 230  | 50 |
| MA611M19 | 19 | 30   | 38 | 11.1 | 52 | 230  | 50 |
| MA611M20 | 20 | 31   | 38 | 11.5 | 52 | 240  | 50 |
| MA611M21 | 21 | 32   | 38 | 11.7 | 52 | 240  | 50 |
| MA611M22 | 22 | 34   | 38 | 12.5 | 52 | 250  | 50 |
| MA611M23 | 23 | 35   | 38 | 12.7 | 52 | 250  | 50 |
| MA611M24 | 24 | 36   | 38 | 14   | 52 | 250  | 50 |
| MA611M25 | 25 | 38   | 38 | 14   | 52 | 270  | 50 |
| MA611M26 | 26 | 38   | 38 | 14.6 | 52 | 270  | 50 |
| MA611M27 | 27 | 40   | 40 | 15.8 | 52 | 280  | 50 |
| MA611M28 | 28 | 42   | 42 | 16.3 | 52 | 320  | 50 |
| MA611M29 | 29 | 42   | 42 | 16.7 | 52 | 320  | 50 |
| MA611M30 | 30 | 46   | 44 | 16.7 | 52 | 370  | 50 |
| MA611M31 | 31 | 46   | 44 | 16.7 | 52 | 370  | 50 |
| MA611M32 | 32 | 48   | 44 | 18.3 | 52 | 380  | 30 |
| MA611M33 | 33 | 50   | 44 | 19.1 | 56 | 410  | 30 |
| MA611M34 | 34 | 51   | 44 | 20   | 56 | 410  | 30 |
| MA611M35 | 35 | 52   | 44 | 20.1 | 56 | 470  | 25 |
| MA611M36 | 36 | 53.5 | 44 | 21.5 | 56 | 470  | 25 |
| MA611M37 | 37 | 54   | 44 | 21.5 | 56 | 470  | 25 |
| MA611M38 | 38 | 56   | 44 | 22.3 | 56 | 470  | 25 |
| MA611M39 | 39 | 56   | 44 | 22.3 | 58 | 480  | 25 |
| MA611M40 | 40 | 58   | 44 | 22.8 | 58 | 540  | 25 |
| MA611M41 | 41 | 60   | 44 | 23   | 58 | 590  | 25 |
| MA611M42 | 42 | 61   | 44 | 23   | 58 | 660  | 25 |
| MA611M43 | 43 | 63   | 44 | 23   | 62 | 700  | 25 |
| MA611M44 | 44 | 65   | 44 | 23   | 62 | 720  | 25 |
| MA611M45 | 45 | 66   | 44 | 23   | 63 | 740  | 25 |
| MA611M46 | 46 | 67   | 44 | 23   | 63 | 770  | 25 |
| MA611M47 | 47 | 68   | 44 | 27   | 68 | 820  | 20 |
| MA611M48 | 48 | 69   | 44 | 27   | 68 | 830  | 20 |
| MA611M49 | 49 | 70   | 44 | 29   | 70 | 830  | 20 |
| MA611M50 | 50 | 71   | 54 | 29.8 | 72 | 970  | 20 |
| MA611M51 | 51 | 71   | 54 | 29.8 | 72 | 1150 | 20 |
| MA611M52 | 52 | 74   | 54 | 29.8 | 72 | 1250 | 20 |
| MA611M54 | 54 | 77   | 54 | 29.8 | 72 | 1250 | 20 |
| MA611M55 | 55 | 77   | 54 | 29.8 | 74 | 1250 | 20 |
| MA611M56 | 56 | 77   | 54 | 31   | 74 | 1450 | 20 |
| MA611M57 | 57 | 80   | 54 | 31   | 74 | 1550 | 20 |
| MA611M58 | 58 | 82   | 54 | 31   | 74 | 1580 | 20 |
| MA611M59 | 59 | 82   | 54 | 33   | 75 | 1600 | 20 |
| MA611M60 | 60 | 84   | 54 | 33   | 80 | 1620 | 20 |
| MA611M62 | 62 | 85   | 54 | 33   | 80 | 1650 | 10 |
| MA611M63 | 63 | 86   | 54 | 33   | 80 | 1720 | 10 |
| MA611M65 | 65 | 88   | 54 | 33   | 80 | 1790 | 10 |
| MA611M67 | 67 | 90   | 54 | 35   | 80 | 1850 | 10 |
| MA611M70 | 70 | 96   | 54 | 35   | 85 | 1920 | 10 |

IMPACT SOCKET

# IMPACT SOCKET

## 3/4" MA631S IMPACT DEEP SOCKET

- 3/4" Drive Deep Length
- 6 Points
- Inch Size

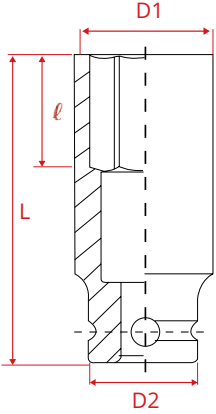

## 3/4" MA631M IMPACT DEEP SOCKET

- 3/4" Drive Deep Length
- 6 Points
- Metric Size

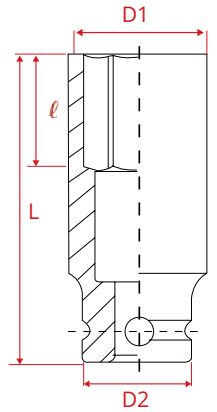

| M7 NO.   | ⊙        | D1   | D2 | ℓ  | L   | ⚖    | 📦  |
|----------|----------|------|----|----|-----|------|----|
|          | inch     |      |    |    |     |      |    |
| MA631S16 | 1/2"     | 22   | 38 | 12 | 90  | 380  | 25 |
| MA631S18 | 9/16"    | 25.5 | 38 | 12 | 90  | 380  | 25 |
| MA631S20 | 5/8"     | 27.5 | 38 | 12 | 90  | 380  | 25 |
| MA631S22 | 11/16"   | 29   | 38 | 12 | 90  | 380  | 25 |
| MA631S24 | 3/4"     | 30   | 38 | 12 | 90  | 390  | 25 |
| MA631S26 | 13/16"   | 32   | 38 | 12 | 90  | 390  | 25 |
| MA631S28 | 7/8"     | 34   | 38 | 19 | 90  | 400  | 25 |
| MA631S30 | 15/16"   | 36   | 38 | 19 | 90  | 440  | 25 |
| MA631S32 | 1"       | 38   | 38 | 19 | 90  | 440  | 25 |
| MA631S34 | 1-1/16"  | 40   | 40 | 19 | 90  | 450  | 25 |
| MA631S36 | 1-1/8"   | 42   | 42 | 19 | 90  | 510  | 25 |
| MA631S38 | 1-3/16"  | 44   | 44 | 19 | 90  | 570  | 20 |
| MA631S40 | 1-1/4"   | 46   | 44 | 19 | 90  | 610  | 20 |
| MA631S42 | 1-5/16"  | 50   | 44 | 19 | 90  | 630  | 20 |
| MA631S44 | 1-3/8"   | 52   | 44 | 19 | 90  | 660  | 20 |
| MA631S46 | 1-7/16"  | 54   | 44 | 19 | 90  | 770  | 20 |
| MA631S48 | 1-1/2"   | 56   | 44 | 22 | 92  | 770  | 20 |
| MA631S50 | 1-9/16"  | 58   | 44 | 40 | 92  | 830  | 20 |
| MA631S52 | 1-5/8"   | 60   | 44 | 40 | 92  | 860  | 20 |
| MA631S54 | 1-11/16" | 63.5 | 44 | 40 | 92  | 870  | 10 |
| MA631S56 | 1-3/4"   | 65   | 44 | 40 | 92  | 1050 | 10 |
| MA631S58 | 1-13/16" | 67   | 44 | 40 | 92  | 1090 | 10 |
| MA631S60 | 1-7/8"   | 68   | 44 | 40 | 92  | 1150 | 10 |
| MA631S62 | 1-15/16" | 70   | 44 | 40 | 92  | 1200 | 10 |
| MA631S64 | 2"       | 71   | 54 | 40 | 95  | 1250 | 10 |
| MA631S66 | 2-1/16"  | 74   | 54 | 40 | 95  | 1310 | 10 |
| MA631S68 | 2-1/8"   | 77   | 54 | 40 | 100 | 1380 | 10 |
| MA631S70 | 2-3/16"  | 77   | 54 | 40 | 100 | 1650 | 10 |
| MA631S72 | 2-1/4"   | 80   | 54 | 40 | 100 | 1700 | 10 |
| MA631S74 | 2-5/16"  | 82   | 54 | 40 | 105 | 1720 | 10 |
| MA631S76 | 2-3/8"   | 84   | 54 | 40 | 105 | 1810 | 6  |
| MA631S78 | 2-7/16"  | 85   | 54 | 40 | 105 | 2050 | 6  |
| MA631S80 | 2-1/2"   | 86   | 54 | 40 | 105 | 2080 | 6  |
| MA631S82 | 2-9/16"  | 88   | 54 | 40 | 105 | 2250 | 1  |
| MA631S84 | 2-5/8"   | 90   | 54 | 40 | 105 | 2300 | 1  |
| MA631S86 | 2-11/16" | 92   | 54 | 40 | 105 | 2350 | 1  |
| MA631S88 | 2-3/4"   | 96   | 54 | 40 | 105 | 2400 | 1  |
| MA631S90 | 2-13/16" | 98   | 54 | 40 | 105 | 2450 | 1  |
| MA631S92 | 2-7/8"   | 100  | 54 | 40 | 105 | 2650 | 1  |
| MA631S94 | 2-15/16" | 102  | 54 | 40 | 105 | 2850 | 1  |
| MA631S96 | 3"       | 104  | 54 | 40 | 105 | 3050 | 1  |

| M7 NO.   | ⊙  | D1   | D2 | ℓ  | L   | ⚖    | 📦  |
|----------|----|------|----|----|-----|------|----|
|          | mm |      |    |    |     |      |    |
| MA631M13 | 13 | 22   | 38 | 12 | 90  | 380  | 25 |
| MA631M14 | 14 | 25.5 | 38 | 12 | 90  | 380  | 25 |
| MA631M15 | 15 | 26   | 38 | 12 | 90  | 380  | 25 |
| MA631M16 | 16 | 27.5 | 38 | 12 | 90  | 380  | 25 |
| MA631M17 | 17 | 28.5 | 38 | 12 | 90  | 390  | 25 |
| MA631M18 | 18 | 29.5 | 38 | 12 | 90  | 390  | 25 |
| MA631M19 | 19 | 30   | 38 | 12 | 90  | 390  | 25 |
| MA631M20 | 20 | 31   | 38 | 19 | 90  | 390  | 25 |
| MA631M21 | 21 | 32   | 38 | 19 | 90  | 400  | 25 |
| MA631M22 | 22 | 34   | 38 | 19 | 90  | 430  | 25 |
| MA631M23 | 23 | 35   | 38 | 19 | 90  | 430  | 25 |
| MA631M24 | 24 | 36   | 38 | 19 | 90  | 440  | 25 |
| MA631M25 | 25 | 38   | 38 | 19 | 90  | 460  | 25 |
| MA631M26 | 26 | 40   | 40 | 19 | 90  | 460  | 25 |
| MA631M27 | 27 | 40   | 40 | 19 | 90  | 500  | 25 |
| MA631M28 | 28 | 42   | 42 | 19 | 90  | 550  | 25 |
| MA631M29 | 29 | 42   | 42 | 19 | 90  | 560  | 25 |
| MA631M30 | 30 | 46   | 44 | 19 | 92  | 620  | 25 |
| MA631M31 | 31 | 47   | 44 | 19 | 92  | 620  | 25 |
| MA631M32 | 32 | 48   | 44 | 19 | 92  | 630  | 25 |
| MA631M33 | 33 | 50   | 44 | 19 | 92  | 670  | 25 |
| MA631M34 | 34 | 51   | 44 | 19 | 92  | 670  | 25 |
| MA631M35 | 35 | 52   | 44 | 19 | 92  | 770  | 25 |
| MA631M36 | 36 | 54   | 44 | 19 | 92  | 790  | 20 |
| MA631M37 | 37 | 54   | 44 | 19 | 92  | 800  | 20 |
| MA631M38 | 38 | 56   | 44 | 19 | 95  | 830  | 20 |
| MA631M39 | 39 | 56   | 44 | 40 | 95  | 850  | 20 |
| MA631M40 | 40 | 58   | 44 | 40 | 100 | 880  | 20 |
| MA631M41 | 41 | 60   | 44 | 40 | 100 | 880  | 20 |
| MA631M42 | 42 | 61   | 44 | 40 | 100 | 1050 | 20 |
| MA631M43 | 43 | 63   | 44 | 40 | 105 | 1050 | 10 |
| MA631M44 | 44 | 64   | 44 | 40 | 105 | 1060 | 10 |
| MA631M45 | 45 | 66   | 44 | 40 | 105 | 1100 | 10 |
| MA631M46 | 46 | 67   | 44 | 40 | 105 | 1150 | 10 |
| MA631M47 | 47 | 68   | 44 | 40 | 105 | 1160 | 10 |
| MA631M48 | 48 | 69   | 44 | 40 | 105 | 1200 | 10 |
| MA631M49 | 49 | 70   | 44 | 40 | 105 | 1240 | 10 |
| MA631M50 | 50 | 71   | 54 | 40 | 105 | 1320 | 10 |
| MA631M51 | 51 | 72   | 54 | 40 | 105 | 1420 | 10 |
| MA631M52 | 52 | 54   | 74 | 40 | 105 | 1530 | 10 |
| MA631M54 | 54 | 76   | 54 | 40 | 105 | 1650 | 10 |
| MA631M55 | 55 | 77   | 54 | 40 | 105 | 1670 | 10 |
| MA631M56 | 56 | 78   | 54 | 40 | 105 | 1720 | 6  |
| MA631M57 | 57 | 80   | 54 | 40 | 105 | 1820 | 6  |
| MA631M58 | 58 | 82   | 54 | 40 | 105 | 1920 | 6  |
| MA631M59 | 59 | 82   | 54 | 40 | 105 | 1920 | 6  |
| MA631M60 | 60 | 84   | 54 | 40 | 105 | 2020 | 6  |
| MA631M62 | 62 | 85   | 54 | 40 | 105 | 2080 | 6  |
| MA631M65 | 65 | 88   | 54 | 40 | 105 | 2300 | 6  |
| MA631M67 | 67 | 92   | 54 | 40 | 105 | 2350 | 6  |
| MA631M70 | 70 | 96   | 54 | 40 | 105 | 2450 | 6  |

# 1"MA811S

## IMPACT STANDARD SOCKET

- 1" Drive Standard Length
- 6 Points
- Inch Size

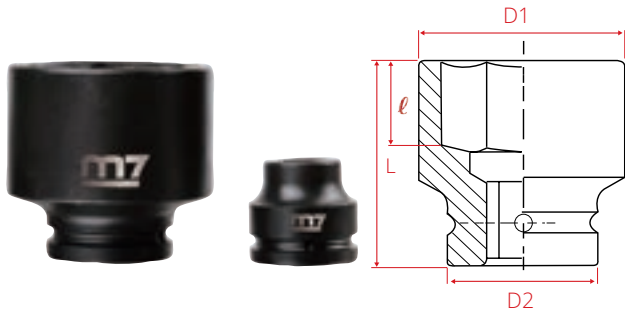

| M7 NO.    | ⊙        | D1   | D2 | ℓ    | L   | ⚖     | 📦  |
|-----------|----------|------|----|------|-----|-------|----|
|           | inch     | mm   | mm | mm   | mm  | g     |    |
| MA811S22  | 11/16"   | 34   | 51 | 8.1  | 58  | 480   | 24 |
| MA811S24  | 3/4"     | 36   | 51 | 9.5  | 58  | 500   | 24 |
| MA811S26  | 13/16"   | 38   | 51 | 11   | 58  | 510   | 24 |
| MA811S28  | 7/8"     | 39   | 51 | 12.5 | 58  | 510   | 24 |
| MA811S30  | 15/16"   | 40   | 51 | 12.5 | 58  | 510   | 24 |
| MA811S32  | 1"       | 42   | 51 | 12.5 | 58  | 520   | 24 |
| MA811S34  | 1-1/16"  | 44   | 51 | 12.5 | 58  | 520   | 24 |
| MA811S36  | 1-1/8"   | 46   | 51 | 12.5 | 58  | 530   | 24 |
| MA811S38  | 1-3/16"  | 48   | 51 | 16.5 | 60  | 550   | 24 |
| MA811S40  | 1-1/4"   | 51   | 51 | 16.5 | 60  | 610   | 24 |
| MA811S42  | 1-5/16"  | 52   | 52 | 19   | 62  | 620   | 24 |
| MA811S44  | 1-3/8"   | 54   | 54 | 19   | 62  | 630   | 24 |
| MA811S46  | 1-7/16"  | 56   | 54 | 19   | 62  | 640   | 24 |
| MA811S48  | 1-1/2"   | 58   | 54 | 22   | 62  | 670   | 24 |
| MA811S50  | 1-9/16"  | 60   | 54 | 22   | 62  | 870   | 24 |
| MA811S52  | 1-5/8"   | 61.5 | 54 | 22   | 62  | 920   | 24 |
| MA811S54  | 1-11/16" | 65   | 54 | 25   | 64  | 920   | 20 |
| MA811S56  | 1-3/4"   | 66   | 58 | 25   | 64  | 1000  | 20 |
| MA811S58  | 1-13/16" | 68   | 58 | 25.6 | 64  | 1000  | 20 |
| MA811S60  | 1-7/8"   | 70   | 58 | 27   | 66  | 1080  | 10 |
| MA811S62  | 1-15/16" | 72   | 58 | 27   | 68  | 1080  | 10 |
| MA811S64  | 2"       | 74   | 58 | 27   | 70  | 1100  | 10 |
| MA811S66  | 2-1/16"  | 75   | 58 | 30   | 70  | 1200  | 10 |
| MA811S68  | 2-1/8"   | 78   | 58 | 30   | 70  | 1250  | 10 |
| MA811S70  | 2-3/16"  | 80   | 62 | 30   | 72  | 1450  | 10 |
| MA811S72  | 2-1/4"   | 84   | 62 | 32.5 | 75  | 1520  | 10 |
| MA811S74  | 2-5/16"  | 86   | 62 | 32.5 | 75  | 1520  | 10 |
| MA811S76  | 2-3/8"   | 87   | 62 | 33.5 | 78  | 1720  | 10 |
| MA811S78  | 2-7/16"  | 89   | 62 | 34   | 78  | 1890  | 10 |
| MA811S80  | 2-1/2"   | 91   | 62 | 34   | 80  | 1900  | 10 |
| MA811S82  | 2-9/16"  | 93   | 62 | 35   | 80  | 1900  | 10 |
| MA811S84  | 2-5/8"   | 95   | 62 | 37.5 | 82  | 2000  | 10 |
| MA811S86  | 2-11/16" | 97   | 62 | 37.5 | 82  | 2200  | 10 |
| MA811S88  | 2-3/4"   | 98   | 62 | 38   | 85  | 2250  | 5  |
| MA811S90  | 2-13/16" | 100  | 62 | 40   | 87  | 2380  | 5  |
| MA811S92  | 2-7/8"   | 102  | 62 | 40   | 87  | 2400  | 5  |
| MA811S94  | 2-15/16" | 104  | 86 | 41   | 95  | 3190  | 5  |
| MA811S96  | 3"       | 106  | 86 | 43   | 98  | 3450  | 5  |
| MA811S98  | 3-1/16"  | 107  | 86 | 43.5 | 100 | 3550  | 5  |
| MA811S100 | 3-1/8"   | 109  | 86 | 43.5 | 100 | 3620  | 5  |
| MA811S104 | 3-1/4"   | 113  | 86 | 43.5 | 100 | 3800  | 5  |
| MA811S108 | 3-3/8"   | 115  | 86 | 47.5 | 100 | 4050  | 5  |
| MA811S112 | 3-1/2"   | 125  | 86 | 49   | 105 | 5170  | 2  |
| MA811S116 | 3-5/8"   | 127  | 86 | 51   | 105 | 5200  | 2  |
| MA811S120 | 3-3/4"   | 130  | 86 | 51   | 105 | 5250  | 2  |
| MA811S124 | 3-7/8"   | 136  | 95 | 55   | 105 | 5990  | 2  |
| MA811S126 | 3-15/16" | 137  | 95 | 55   | 105 | 6000  | 2  |
| MA811S128 | 4"       | 140  | 95 | 56   | 105 | 6000  | 2  |
| MA811S132 | 4-1/8"   | 143  | 95 | 57.5 | 105 | 6500  | 2  |
| MA811S136 | 4-1/4"   | 147  | 95 | 58.5 | 105 | 7200  | 2  |
| MA811S144 | 4-1/2"   | 152  | 95 | 61   | 105 | 10000 | 2  |

# 1"MA811M

## IMPACT STANDARD SOCKET

- 1" Drive Standard Length
- 6 Points
- Metric Size



| M7 NO.    | ⊙   | D1   | D2 | ℓ    | L   | ⚖     | 📦  |
|-----------|-----|------|----|------|-----|-------|----|
|           | mm  | mm   | mm | mm   | mm  | g     |    |
| MA811M17  | 17  | 34   | 51 | 11.5 | 58  | 490   | 25 |
| MA811M18  | 18  | 35   | 51 | 11.5 | 58  | 500   | 25 |
| MA811M19  | 19  | 35   | 51 | 11.5 | 58  | 500   | 25 |
| MA811M20  | 20  | 37   | 51 | 11.5 | 58  | 500   | 25 |
| MA811M21  | 21  | 38   | 51 | 11.5 | 58  | 500   | 25 |
| MA811M22  | 22  | 39   | 51 | 12.5 | 58  | 510   | 25 |
| MA811M23  | 23  | 40   | 51 | 13   | 58  | 510   | 25 |
| MA811M24  | 24  | 40.5 | 51 | 14   | 58  | 510   | 25 |
| MA811M25  | 25  | 41   | 51 | 14.5 | 58  | 510   | 25 |
| MA811M26  | 26  | 42.5 | 51 | 15   | 58  | 520   | 25 |
| MA811M27  | 27  | 44   | 51 | 16   | 58  | 520   | 25 |
| MA811M28  | 28  | 45   | 51 | 16   | 58  | 530   | 25 |
| MA811M29  | 29  | 46   | 51 | 16.5 | 60  | 530   | 25 |
| MA811M30  | 30  | 48   | 51 | 17   | 60  | 530   | 25 |
| MA811M32  | 32  | 51   | 51 | 18.5 | 62  | 590   | 25 |
| MA811M33  | 33  | 52   | 52 | 19.5 | 62  | 620   | 25 |
| MA811M34  | 34  | 54   | 54 | 19.5 | 62  | 640   | 20 |
| MA811M35  | 35  | 54   | 54 | 20.5 | 62  | 650   | 20 |
| MA811M36  | 36  | 56   | 54 | 21.5 | 62  | 670   | 20 |
| MA811M37  | 37  | 57   | 54 | 22   | 62  | 670   | 20 |
| MA811M38  | 38  | 58   | 54 | 22.5 | 62  | 680   | 20 |
| MA811M39  | 39  | 58.7 | 54 | 23   | 62  | 770   | 20 |
| MA811M40  | 40  | 60   | 54 | 23   | 62  | 870   | 20 |
| MA811M41  | 41  | 61.5 | 54 | 23   | 62  | 920   | 15 |
| MA811M42  | 42  | 63   | 54 | 23   | 64  | 980   | 15 |
| MA811M43  | 43  | 65   | 54 | 23   | 64  | 1000  | 15 |
| MA811M44  | 44  | 65   | 54 | 23   | 64  | 1000  | 15 |
| MA811M45  | 45  | 66   | 54 | 23   | 64  | 1000  | 15 |
| MA811M46  | 46  | 68   | 54 | 23   | 64  | 1000  | 15 |
| MA811M47  | 47  | 69   | 54 | 24   | 66  | 1000  | 10 |
| MA811M48  | 48  | 70   | 54 | 27   | 66  | 1050  | 10 |
| MA811M49  | 49  | 70   | 54 | 27   | 66  | 1050  | 10 |
| MA811M50  | 50  | 73   | 54 | 27   | 70  | 1070  | 10 |
| MA811M51  | 51  | 73   | 54 | 27   | 70  | 1070  | 10 |
| MA811M52  | 52  | 75   | 54 | 27   | 70  | 1200  | 10 |
| MA811M53  | 53  | 75   | 54 | 27   | 70  | 1200  | 10 |
| MA811M54  | 54  | 75   | 54 | 28   | 70  | 1200  | 10 |
| MA811M55  | 55  | 79   | 54 | 28   | 72  | 1440  | 10 |
| MA811M56  | 56  | 80   | 54 | 32   | 72  | 1350  | 10 |
| MA811M57  | 57  | 80   | 54 | 32   | 72  | 1350  | 10 |
| MA811M58  | 58  | 85   | 54 | 32   | 75  | 1620  | 10 |
| MA811M59  | 59  | 85   | 54 | 36   | 75  | 1620  | 10 |
| MA811M60  | 60  | 87   | 54 | 36   | 78  | 1730  | 10 |
| MA811M61  | 61  | 87   | 54 | 36   | 78  | 1730  | 10 |
| MA811M62  | 62  | 91   | 54 | 36   | 80  | 1900  | 10 |
| MA811M65  | 65  | 93   | 54 | 36   | 80  | 1900  | 7  |
| MA811M70  | 70  | 104  | 86 | 40   | 85  | 2190  | 7  |
| MA811M73  | 73  | 104  | 86 | 40   | 90  | 2800  | 7  |
| MA811M75  | 75  | 104  | 86 | 40   | 95  | 3200  | 5  |
| MA811M76  | 76  | 106  | 86 | 43   | 98  | 3480  | 5  |
| MA811M80  | 80  | 109  | 86 | 47   | 100 | 3650  | 5  |
| MA811M85  | 85  | 115  | 86 | 47   | 100 | 4100  | 5  |
| MA811M90  | 90  | 125  | 86 | 47   | 105 | 5200  | 5  |
| MA811M95  | 95  | 130  | 86 | 50   | 105 | 5250  | 2  |
| MA811M100 | 100 | 137  | 95 | 55   | 105 | 6050  | 2  |
| MA811M105 | 105 | 143  | 95 | 55   | 105 | 6550  | 2  |
| MA811M110 | 110 | 147  | 95 | 55   | 105 | 7250  | 2  |
| MA811M115 | 115 | 152  | 95 | 55   | 105 | 10000 | 2  |
| MA811M120 | 120 | 160  | 95 | 60   | 110 | 14000 | 2  |
| MA811M125 | 125 | 165  | 95 | 63   | 115 | 19000 | 2  |

IMPACT SOCKET

# IMPACT SOCKET

## 1" MA831M IMPACT DEEP SOCKET

- 1" Drive Deep Length
- 6 Points
- Inch Size

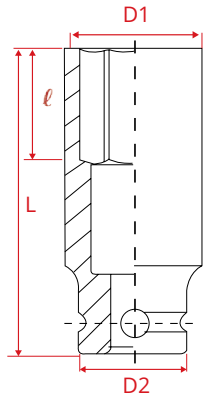

## 1" MA831S IMPACT DEEP SOCKET

- 1" Drive Deep Length
- 6 Points
- Inch Size

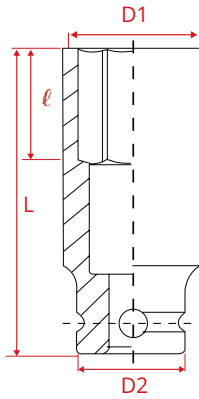

| M7 NO.    | ⊙        | D1   | D2 | ℓ  | L   | ⚖     | 📦  |
|-----------|----------|------|----|----|-----|-------|----|
|           | inch     | mm   | mm | mm | mm  | g     |    |
| MA831S22  | 11/16"   | 34   | 51 | 16 | 90  | 620   | 20 |
| MA831S24  | 3/4"     | 36   | 51 | 16 | 90  | 700   | 20 |
| MA831S26  | 13/16"   | 38   | 51 | 16 | 90  | 700   | 20 |
| MA831S28  | 7/8"     | 39   | 51 | 16 | 90  | 710   | 20 |
| MA831S30  | 15/16"   | 40   | 51 | 16 | 90  | 720   | 20 |
| MA831S32  | 1"       | 42   | 51 | 19 | 90  | 760   | 20 |
| MA831S34  | 1-1/16"  | 44   | 51 | 19 | 90  | 800   | 20 |
| MA831S36  | 1-1/8"   | 46   | 51 | 19 | 90  | 800   | 20 |
| MA831S38  | 1-3/16"  | 48   | 51 | 19 | 90  | 820   | 20 |
| MA831S40  | 1-1/4"   | 51   | 51 | 19 | 90  | 910   | 20 |
| MA831S42  | 1-5/16"  | 52   | 52 | 23 | 90  | 910   | 20 |
| MA831S44  | 1-3/8"   | 54   | 54 | 23 | 90  | 910   | 20 |
| MA831S46  | 1-7/16"  | 56   | 54 | 23 | 90  | 950   | 20 |
| MA831S48  | 1-1/2"   | 58   | 54 | 23 | 92  | 1000  | 20 |
| MA831S50  | 1-9/16"  | 60   | 54 | 40 | 92  | 1200  | 5  |
| MA831S52  | 1-5/8"   | 61.5 | 54 | 40 | 92  | 1200  | 5  |
| MA831S54  | 1-11/16" | 65   | 54 | 40 | 92  | 1200  | 5  |
| MA831S56  | 1-3/4"   | 66   | 58 | 40 | 92  | 1350  | 5  |
| MA831S58  | 1-13/16" | 68   | 58 | 40 | 92  | 1350  | 5  |
| MA831S60  | 1-7/8"   | 70   | 58 | 40 | 92  | 1500  | 5  |
| MA831S62  | 1-15/16" | 72   | 58 | 40 | 92  | 1560  | 5  |
| MA831S64  | 2"       | 74   | 58 | 40 | 95  | 1560  | 5  |
| MA831S66  | 2-1/16"  | 75   | 58 | 52 | 95  | 1600  | 5  |
| MA831S68  | 2-1/8"   | 78   | 58 | 52 | 100 | 1750  | 5  |
| MA831S70  | 2-3/16"  | 80   | 62 | 52 | 100 | 2000  | 5  |
| MA831S72  | 2-1/4"   | 84   | 62 | 52 | 100 | 2200  | 5  |
| MA831S74  | 2-5/16"  | 86   | 62 | 52 | 105 | 2260  | 5  |
| MA831S76  | 2-3/8"   | 87   | 62 | 52 | 105 | 2350  | 5  |
| MA831S78  | 2-7/16"  | 89   | 62 | 60 | 110 | 2500  | 5  |
| MA831S80  | 2-1/2"   | 91   | 62 | 60 | 110 | 2580  | 5  |
| MA831S82  | 2-9/16"  | 93   | 62 | 60 | 120 | 3000  | 5  |
| MA831S84  | 2-5/8"   | 95   | 62 | 60 | 120 | 3220  | 5  |
| MA831S86  | 2-11/16" | 97   | 62 | 60 | 124 | 3250  | 5  |
| MA831S88  | 2-3/4"   | 98   | 62 | 60 | 124 | 3280  | 5  |
| MA831S90  | 2-13/16" | 100  | 62 | 60 | 128 | 3700  | 5  |
| MA831S92  | 2-7/8"   | 102  | 62 | 60 | 128 | 4150  | 5  |
| MA831S94  | 2-15/16" | 104  | 86 | 60 | 135 | 4550  | 5  |
| MA831S96  | 3"       | 106  | 86 | 60 | 135 | 4550  | 4  |
| MA831S98  | 3-1/16"  | 107  | 86 | 60 | 135 | 4850  | 4  |
| MA831S100 | 3-1/8"   | 109  | 86 | 75 | 135 | 4850  | 4  |
| MA831S104 | 3-1/4"   | 113  | 86 | 75 | 135 | 5150  | 4  |
| MA831S108 | 3-3/8"   | 115  | 86 | 75 | 140 | 5250  | 2  |
| MA831S112 | 3-1/2"   | 125  | 86 | 75 | 140 | 5750  | 2  |
| MA831S116 | 3-5/8"   | 127  | 86 | 75 | 140 | 6050  | 2  |
| MA831S120 | 3-3/4"   | 130  | 86 | 75 | 140 | 6320  | 2  |
| MA831S124 | 3-7/8"   | 136  | 95 | 75 | 140 | 7400  | 2  |
| MA831S126 | 3-15/16" | 137  | 95 | 75 | 140 | 7500  | 2  |
| MA831S128 | 4"       | 140  | 95 | 75 | 155 | 7500  | 2  |
| MA831S132 | 4-1/8"   | 143  | 95 | 75 | 155 | 9800  | 2  |
| MA831S136 | 4-1/4"   | 147  | 95 | 75 | 155 | 10000 | 2  |
| MA831S144 | 4-1/2"   | 152  | 95 | 75 | 155 | 10000 | 2  |

| M7 NO.    | ⊙   | D1   | D2 | ℓ  | L   | ⚖     | 📦  |
|-----------|-----|------|----|----|-----|-------|----|
|           | mm  | mm   | mm | mm | mm  | g     |    |
| MA831M17  | 17  | 34   | 51 | 16 | 90  | 620   | 20 |
| MA831M18  | 18  | 35   | 51 | 16 | 90  | 630   | 20 |
| MA831M19  | 19  | 36   | 51 | 16 | 90  | 700   | 20 |
| MA831M20  | 20  | 37   | 51 | 16 | 90  | 700   | 20 |
| MA831M21  | 21  | 38   | 51 | 16 | 90  | 710   | 20 |
| MA831M22  | 22  | 39   | 51 | 16 | 90  | 710   | 20 |
| MA831M23  | 23  | 40   | 51 | 16 | 90  | 710   | 20 |
| MA831M24  | 24  | 40.5 | 51 | 16 | 90  | 720   | 20 |
| MA831M25  | 25  | 41   | 51 | 19 | 90  | 720   | 20 |
| MA831M26  | 26  | 42.5 | 51 | 19 | 90  | 750   | 20 |
| MA831M27  | 27  | 44   | 51 | 19 | 90  | 800   | 20 |
| MA831M28  | 28  | 45   | 51 | 19 | 90  | 800   | 20 |
| MA831M29  | 29  | 46   | 51 | 19 | 90  | 800   | 20 |
| MA831M30  | 30  | 48   | 51 | 19 | 90  | 800   | 20 |
| MA831M32  | 32  | 51   | 51 | 19 | 90  | 910   | 20 |
| MA831M33  | 33  | 52   | 52 | 30 | 90  | 910   | 20 |
| MA831M34  | 34  | 54   | 54 | 30 | 90  | 950   | 10 |
| MA831M35  | 35  | 54   | 54 | 30 | 90  | 950   | 10 |
| MA831M36  | 36  | 56   | 54 | 30 | 90  | 950   | 10 |
| MA831M37  | 37  | 57   | 54 | 30 | 90  | 960   | 10 |
| MA831M38  | 38  | 58   | 54 | 30 | 92  | 990   | 10 |
| MA831M39  | 39  | 58.7 | 54 | 40 | 92  | 1060  | 10 |
| MA831M40  | 40  | 60   | 54 | 40 | 92  | 1200  | 10 |
| MA831M41  | 41  | 61.5 | 54 | 40 | 92  | 1200  | 10 |
| MA831M42  | 42  | 63   | 54 | 40 | 92  | 1200  | 10 |
| MA831M43  | 43  | 65   | 54 | 40 | 92  | 1200  | 10 |
| MA831M44  | 44  | 65   | 54 | 40 | 92  | 1380  | 10 |
| MA831M45  | 45  | 66   | 54 | 40 | 92  | 1390  | 10 |
| MA831M46  | 46  | 68   | 54 | 40 | 92  | 1400  | 10 |
| MA831M47  | 47  | 69   | 54 | 40 | 92  | 1410  | 10 |
| MA831M48  | 48  | 70   | 54 | 40 | 92  | 1450  | 10 |
| MA831M49  | 49  | 72   | 54 | 40 | 92  | 1430  | 10 |
| MA831M50  | 50  | 73   | 54 | 40 | 95  | 1570  | 10 |
| MA831M51  | 51  | 74   | 54 | 40 | 95  | 1570  | 10 |
| MA831M52  | 52  | 75   | 54 | 52 | 95  | 1600  | 10 |
| MA831M54  | 54  | 78   | 54 | 52 | 100 | 1750  | 10 |
| MA831M55  | 55  | 79   | 54 | 52 | 100 | 1950  | 10 |
| MA831M56  | 56  | 80   | 54 | 52 | 100 | 2150  | 10 |
| MA831M57  | 57  | 84   | 54 | 52 | 100 | 2200  | 10 |
| MA831M58  | 58  | 85   | 54 | 52 | 100 | 2100  | 10 |
| MA831M59  | 59  | 86   | 54 | 52 | 105 | 2350  | 10 |
| MA831M60  | 60  | 87   | 54 | 52 | 105 | 2350  | 10 |
| MA831M62  | 62  | 89   | 54 | 60 | 110 | 2450  | 10 |
| MA831M63  | 63  | 91   | 54 | 60 | 110 | 2550  | 10 |
| MA831M65  | 65  | 93   | 54 | 60 | 120 | 2950  | 10 |
| MA831M70  | 70  | 98   | 86 | 60 | 124 | 3300  | 5  |
| MA831M73  | 73  | 102  | 86 | 60 | 128 | 4150  | 5  |
| MA831M75  | 75  | 104  | 86 | 60 | 135 | 4650  | 5  |
| MA831M76  | 76  | 106  | 86 | 60 | 135 | 4950  | 5  |
| MA831M78  | 78  | 107  | 86 | 60 | 135 | 5450  | 5  |
| MA831M80  | 80  | 109  | 86 | 75 | 135 | 6000  | 5  |
| MA831M85  | 85  | 115  | 86 | 75 | 140 | 7500  | 5  |
| MA831M90  | 90  | 125  | 86 | 75 | 140 | 9000  | 5  |
| MA831M95  | 95  | 130  | 86 | 75 | 140 | 10500 | 2  |
| MA831M100 | 100 | 137  | 95 | 75 | 140 | 12000 | 2  |
| MA831M105 | 105 | 143  | 95 | 75 | 155 | 13500 | 2  |
| MA831M110 | 110 | 147  | 95 | 75 | 155 | 15000 | 2  |
| MA831M115 | 115 | 152  | 95 | 75 | 155 | 16500 | 2  |

# 1-1/2" MA911S

## IMPACT STANDARD SOCKET

- 1-1/2" Drive Standard Length
- 6 Points
- Inch Size

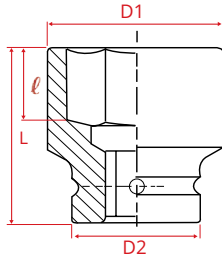

| M7 NO.    | ⌀        | D1  | D2  | ℓ    | L   | ⚖     | 📦 |
|-----------|----------|-----|-----|------|-----|-------|---|
|           |          |     |     |      |     |       |   |
| MA911S38  | 1-3/16"  | 56  | 86  | 16.5 | 78  | 2200  | 1 |
| MA911S40  | 1-1/4"   | 58  | 86  | 16.5 | 78  | 2200  | 1 |
| MA911S42  | 1-5/16"  | 60  | 86  | 19   | 78  | 2200  | 1 |
| MA911S44  | 1-3/8"   | 62  | 86  | 19.5 | 78  | 2200  | 1 |
| MA911S46  | 1-7/16"  | 64  | 86  | 22.5 | 78  | 2000  | 1 |
| MA911S48  | 1-1/2"   | 66  | 86  | 24   | 78  | 2200  | 1 |
| MA911S50  | 1-9/16"  | 68  | 86  | 25.5 | 78  | 2200  | 1 |
| MA911S52  | 1-5/8"   | 70  | 86  | 27   | 80  | 2200  | 1 |
| MA911S54  | 1-11/16" | 71  | 86  | 27   | 80  | 2200  | 1 |
| MA911S56  | 1-3/4"   | 75  | 86  | 28.5 | 84  | 2300  | 1 |
| MA911S58  | 1-13/16" | 76  | 86  | 29   | 84  | 2300  | 1 |
| MA911S60  | 1-7/8"   | 78  | 86  | 30   | 84  | 2300  | 1 |
| MA911S62  | 1-15/16" | 80  | 86  | 31   | 87  | 2400  | 1 |
| MA911S64  | 2"       | 82  | 86  | 32   | 87  | 2400  | 1 |
| MA911S66  | 2-1/16"  | 83  | 86  | 33   | 87  | 2400  | 1 |
| MA911S68  | 2-1/8"   | 86  | 86  | 34.5 | 90  | 2500  | 1 |
| MA911S70  | 2-3/16"  | 86  | 86  | 35   | 90  | 2500  | 1 |
| MA911S72  | 2-1/4"   | 86  | 86  | 36   | 92  | 2800  | 1 |
| MA911S74  | 2-5/16"  | 92  | 86  | 37   | 92  | 3100  | 1 |
| MA911S76  | 2-3/8"   | 93  | 86  | 38.5 | 92  | 3100  | 1 |
| MA911S78  | 2-7/16"  | 96  | 86  | 39.5 | 95  | 3400  | 1 |
| MA911S80  | 2-1/2"   | 97  | 86  | 40.5 | 95  | 3400  | 1 |
| MA911S82  | 2-9/16"  | 97  | 86  | 41   | 95  | 3400  | 1 |
| MA911S84  | 2-5/8"   | 103 | 86  | 42.5 | 100 | 3600  | 1 |
| MA911S86  | 2-11/16" | 104 | 86  | 43   | 100 | 3800  | 1 |
| MA911S88  | 2-3/4"   | 105 | 86  | 44.5 | 100 | 3800  | 1 |
| MA911S90  | 2-13/16" | 108 | 86  | 45.3 | 103 | 4000  | 1 |
| MA911S92  | 2-7/8"   | 108 | 86  | 46.5 | 103 | 4100  | 1 |
| MA911S94  | 2-15/16" | 110 | 86  | 47   | 103 | 4200  | 1 |
| MA911S96  | 3"       | 110 | 86  | 48   | 103 | 4300  | 1 |
| MA911S98  | 3-1/16"  | 115 | 86  | 49.5 | 110 | 4400  | 1 |
| MA911S100 | 3-1/8"   | 116 | 86  | 51   | 110 | 4500  | 1 |
| MA911S102 | 3-3/16"  | 125 | 86  | 51   | 110 | 4800  | 1 |
| MA911S104 | 3-1/4"   | 125 | 86  | 52   | 110 | 5500  | 1 |
| MA911S106 | 3-5/16"  | 125 | 86  | 53.5 | 118 | 5500  | 1 |
| MA911S108 | 3-3/8"   | 125 | 86  | 54   | 118 | 5500  | 1 |
| MA911S110 | 3-7/16"  | 128 | 86  | 55   | 118 | 5700  | 1 |
| MA911S112 | 3-1/2"   | 130 | 86  | 57.5 | 118 | 5800  | 1 |
| MA911S114 | 3-9/16"  | 132 | 86  | 57.5 | 118 | 6000  | 1 |
| MA911S116 | 3-5/8"   | 134 | 86  | 58   | 118 | 6200  | 1 |
| MA911S118 | 3-11/16" | 136 | 86  | 59.5 | 118 | 6400  | 1 |
| MA911S120 | 3-3/4"   | 137 | 95  | 60.5 | 118 | 6600  | 1 |
| MA911S122 | 3-13/16" | 140 | 95  | 61.5 | 125 | 8600  | 1 |
| MA911S124 | 3-7/8"   | 142 | 95  | 63.5 | 125 | 8900  | 1 |
| MA911S126 | 3-15/16" | 144 | 95  | 63.5 | 125 | 9300  | 1 |
| MA911S128 | 4"       | 145 | 95  | 63.5 | 125 | 9450  | 1 |
| MA911S130 | 4-1/16"  | 146 | 95  | 66   | 125 | 9450  | 1 |
| MA911S132 | 4-1/8"   | 150 | 95  | 66   | 125 | 9500  | 1 |
| MA911S134 | 4-3/16"  | 151 | 95  | 67   | 125 | 9500  | 1 |
| MA911S136 | 4-1/4"   | 153 | 95  | 70   | 125 | 10300 | 1 |
| MA911S138 | 4-5/16"  | 156 | 95  | 70   | 125 | 10700 | 1 |
| MA911S140 | 4-3/8"   | 160 | 95  | 70   | 125 | 11500 | 1 |
| MA911S142 | 4-7/16"  | 162 | 95  | 71.5 | 125 | 11800 | 1 |
| MA911S144 | 4-1/2"   | 163 | 95  | 72   | 135 | 12000 | 1 |
| MA911S146 | 4-5/8"   | 165 | 95  | 76.5 | 135 | 12600 | 1 |
| MA911S148 | 4-3/4"   | 168 | 95  | 76.5 | 135 | 13500 | 1 |
| MA911S150 | 5"       | 179 | 127 | 77   | 140 | 14500 | 1 |

# 1-1/2" MA911M

## IMPACT STANDARD SOCKET

- 1-1/2" Drive Standard Length
- 6 Points

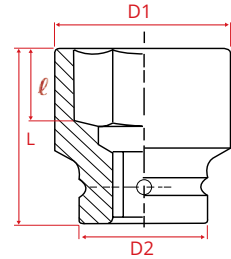

| M7 NO.    | ⌀   | D1  | D2  | ℓ  | L   | ⚖     | 📦 |
|-----------|-----|-----|-----|----|-----|-------|---|
|           |     |     |     |    |     |       |   |
| MA911M30  | 30  | 56  | 86  | 17 | 78  | 2200  | 1 |
| MA911M32  | 32  | 58  | 86  | 19 | 78  | 2200  | 1 |
| MA911M34  | 34  | 61  | 86  | 20 | 78  | 2200  | 1 |
| MA911M35  | 35  | 61  | 86  | 20 | 78  | 2200  | 1 |
| MA911M36  | 36  | 64  | 86  | 22 | 78  | 2200  | 1 |
| MA911M38  | 38  | 66  | 86  | 23 | 78  | 2200  | 1 |
| MA911M40  | 40  | 68  | 86  | 23 | 78  | 2200  | 1 |
| MA911M41  | 41  | 70  | 86  | 25 | 80  | 2200  | 1 |
| MA911M42  | 42  | 70  | 86  | 25 | 80  | 2200  | 1 |
| MA911M46  | 46  | 76  | 86  | 29 | 84  | 2200  | 1 |
| MA911M50  | 50  | 81  | 86  | 30 | 87  | 2400  | 1 |
| MA911M51  | 51  | 81  | 86  | 30 | 87  | 2400  | 1 |
| MA911M52  | 52  | 87  | 86  | 30 | 88  | 2400  | 1 |
| MA911M53  | 53  | 87  | 86  | 30 | 88  | 2400  | 1 |
| MA911M54  | 54  | 87  | 86  | 30 | 88  | 2400  | 1 |
| MA911M55  | 55  | 87  | 86  | 34 | 90  | 2500  | 1 |
| MA911M57  | 57  | 87  | 86  | 34 | 90  | 2500  | 1 |
| MA911M58  | 58  | 87  | 86  | 34 | 90  | 2500  | 1 |
| MA911M60  | 60  | 93  | 86  | 35 | 92  | 3100  | 1 |
| MA911M62  | 62  | 93  | 86  | 35 | 92  | 3100  | 1 |
| MA911M63  | 63  | 93  | 86  | 35 | 92  | 3100  | 1 |
| MA911M65  | 65  | 97  | 86  | 35 | 95  | 3400  | 1 |
| MA911M66  | 66  | 97  | 86  | 35 | 95  | 3400  | 1 |
| MA911M67  | 67  | 97  | 86  | 35 | 95  | 3400  | 1 |
| MA911M68  | 68  | 104 | 86  | 35 | 100 | 3800  | 1 |
| MA911M70  | 70  | 105 | 86  | 35 | 100 | 3800  | 1 |
| MA911M72  | 72  | 105 | 86  | 35 | 100 | 3800  | 1 |
| MA911M73  | 73  | 108 | 86  | 35 | 103 | 4100  | 1 |
| MA911M75  | 75  | 110 | 86  | 35 | 103 | 4200  | 1 |
| MA911M76  | 76  | 110 | 86  | 35 | 103 | 4300  | 1 |
| MA911M78  | 78  | 115 | 86  | 38 | 110 | 4400  | 1 |
| MA911M80  | 80  | 116 | 86  | 38 | 110 | 4650  | 1 |
| MA911M85  | 85  | 125 | 86  | 41 | 118 | 5500  | 1 |
| MA911M90  | 90  | 130 | 86  | 44 | 118 | 5800  | 1 |
| MA911M95  | 95  | 137 | 95  | 46 | 118 | 6600  | 1 |
| MA911M100 | 100 | 144 | 95  | 48 | 125 | 9300  | 1 |
| MA911M105 | 105 | 150 | 95  | 51 | 125 | 9500  | 1 |
| MA911M110 | 110 | 156 | 95  | 54 | 125 | 10500 | 1 |
| MA911M115 | 115 | 160 | 95  | 56 | 135 | 12100 | 1 |
| MA911M120 | 120 | 168 | 95  | 58 | 135 | 13200 | 1 |
| MA911M125 | 125 | 175 | 95  | 61 | 135 | 14000 | 1 |
| MA911M130 | 130 | 180 | 127 | 64 | 145 | 18000 | 1 |
| MA911M135 | 135 | 186 | 127 | 68 | 150 | 19000 | 1 |
| MA911M140 | 140 | 192 | 127 | 70 | 150 | 20000 | 1 |
| MA911M145 | 145 | 198 | 127 | 74 | 150 | 21000 | 1 |
| MA911M150 | 150 | 203 | 127 | 78 | 150 | 22000 | 1 |
| MA911M155 | 155 | 209 | 127 | 78 | 150 | 24500 | 1 |
| MA911M160 | 160 | 222 | 127 | 82 | 175 | 29800 | 1 |
| MA911M165 | 165 | 228 | 127 | 90 | 175 | 32000 | 1 |
| MA911M175 | 175 | 235 | 127 | 94 | 175 | 34500 | 1 |

IMPACT SOCKET



# IMPACT SOCKET

## 1-1/2" MA931S IMPACT DEEP SOCKET

- 1-1/2" Drive Deep Length
- 6 Points
- Inch Size

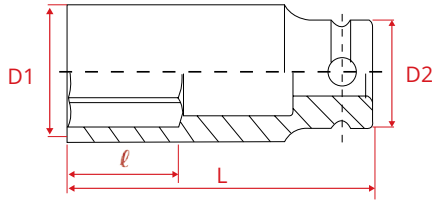

## 1-1/2" MA931M IMPACT DEEP SOCKET

- 1-1/2" Drive Deep Length
- 6 Points
- Metric Size

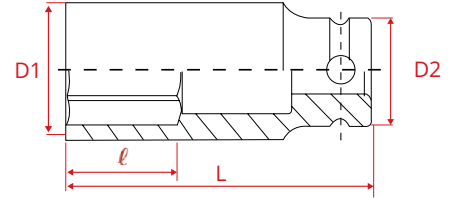

| M7 NO.    | ⊙        | D1  | D2 | ℓ    | L   | ⚖     | 📦 |
|-----------|----------|-----|----|------|-----|-------|---|
|           | inch     | mm  | mm | mm   | mm  | g     |   |
| MA931S48  | 1-1/2"   | 68  | 86 | 27   | 115 | 3200  | 1 |
| MA931S52  | 1-5/8"   | 70  | 86 | 27   | 115 | 3200  | 1 |
| MA931S54  | 1-11/16" | 73  | 86 | 27   | 115 | 3200  | 1 |
| MA931S56  | 1-3/4"   | 75  | 86 | 28.5 | 115 | 3200  | 1 |
| MA931S58  | 1-13/16" | 76  | 86 | 29   | 115 | 3200  | 1 |
| MA931S60  | 1-7/8"   | 78  | 86 | 30   | 115 | 3200  | 1 |
| MA931S62  | 1-15/16" | 80  | 86 | 31   | 115 | 3600  | 1 |
| MA931S64  | 2"       | 82  | 86 | 32   | 135 | 3800  | 1 |
| MA931S66  | 2-1/16"  | 83  | 86 | 33   | 140 | 3900  | 1 |
| MA931S68  | 2-1/8"   | 86  | 86 | 35   | 140 | 3900  | 1 |
| MA931S70  | 2-3/16"  | 86  | 86 | 35   | 140 | 3900  | 1 |
| MA931S72  | 2-1/4"   | 86  | 86 | 36   | 150 | 4700  | 1 |
| MA931S74  | 2-5/16"  | 92  | 86 | 37   | 150 | 4700  | 1 |
| MA931S76  | 2-3/8"   | 93  | 86 | 38.5 | 150 | 5200  | 1 |
| MA931S78  | 2-7/16"  | 96  | 86 | 39.5 | 150 | 5200  | 1 |
| MA931S80  | 2-1/2"   | 97  | 86 | 40.5 | 150 | 5200  | 1 |
| MA931S82  | 2-9/16"  | 97  | 86 | 41   | 150 | 5700  | 1 |
| MA931S84  | 2-5/8"   | 103 | 86 | 42.5 | 150 | 5700  | 1 |
| MA931S86  | 2-11/16" | 104 | 86 | 43   | 150 | 6300  | 1 |
| MA931S88  | 2-3/4"   | 105 | 86 | 45   | 160 | 6700  | 1 |
| MA931S90  | 2-13/16" | 108 | 86 | 45.5 | 160 | 6700  | 1 |
| MA931S92  | 2-7/8"   | 108 | 86 | 46.5 | 160 | 7320  | 1 |
| MA931S94  | 2-15/16" | 110 | 86 | 47   | 170 | 7800  | 1 |
| MA931S96  | 3"       | 110 | 86 | 48   | 170 | 8500  | 1 |
| MA931S98  | 3-1/16"  | 115 | 86 | 49.5 | 170 | 8500  | 1 |
| MA931S100 | 3-1/8"   | 116 | 86 | 51   | 170 | 8500  | 1 |
| MA931S102 | 3-3/16"  | 125 | 86 | 51   | 170 | 9900  | 1 |
| MA931S104 | 3-1/4"   | 125 | 86 | 52   | 170 | 9900  | 1 |
| MA931S106 | 3-5/16"  | 125 | 86 | 53.5 | 170 | 9900  | 1 |
| MA931S108 | 3-3/8"   | 125 | 86 | 54   | 170 | 9900  | 1 |
| MA931S110 | 3-7/16"  | 128 | 86 | 55   | 170 | 10300 | 1 |
| MA931S112 | 3-1/2"   | 130 | 86 | 57.5 | 170 | 10700 | 1 |
| MA931S114 | 3-9/16"  | 132 | 86 | 57.5 | 170 | 10700 | 1 |
| MA931S116 | 3-5/8"   | 134 | 86 | 58   | 170 | 11000 | 1 |
| MA931S118 | 3-11/16" | 136 | 86 | 59.5 | 170 | 11200 | 1 |
| MA931S120 | 3-3/4"   | 137 | 95 | 60.5 | 180 | 12200 | 1 |
| MA931S122 | 3-13/16" | 140 | 95 | 61.5 | 180 | 12500 | 1 |
| MA931S124 | 3-7/8"   | 142 | 95 | 63.5 | 180 | 13100 | 1 |
| MA931S126 | 3-15/16" | 144 | 95 | 63.5 | 190 | 14100 | 1 |
| MA931S128 | 4"       | 145 | 95 | 63.5 | 190 | 14900 | 1 |
| MA931S130 | 4-1/16"  | 146 | 95 | 66   | 190 | 15200 | 1 |
| MA931S132 | 4-1/8"   | 150 | 95 | 66   | 190 | 15800 | 1 |
| MA931S134 | 4-3/16"  | 151 | 95 | 67   | 190 | 16500 | 1 |
| MA931S136 | 4-1/4"   | 153 | 95 | 70   | 190 | 16800 | 1 |
| MA931S138 | 4-5/16"  | 156 | 95 | 70   | 200 | 17000 | 1 |
| MA931S140 | 4-3/8"   | 160 | 95 | 70   | 200 | 18200 | 1 |
| MA931S142 | 4-7/16"  | 162 | 95 | 71.5 | 200 | 19100 | 1 |
| MA931S144 | 4-1/2"   | 163 | 95 | 72   | 210 | 20100 | 1 |
| MA931S148 | 4-5/8"   | 165 | 95 | 76.5 | 210 | 20900 | 1 |
| MA931S152 | 4-3/4"   | 168 | 95 | 76.5 | 210 | 21500 | 1 |

| M7 NO.    | ⊙   | D1  | D2 | ℓ  | L   | ⚖     | 📦 |
|-----------|-----|-----|----|----|-----|-------|---|
|           | mm  | mm  | mm | mm | mm  | g     |   |
| MA931M41  | 41  | 70  | 86 | 25 | 115 | 3200  | 1 |
| MA931M42  | 42  | 73  | 86 | 27 | 115 | 3200  | 1 |
| MA931M46  | 46  | 76  | 86 | 29 | 115 | 3200  | 1 |
| MA931M49  | 49  | 80  | 86 | 30 | 115 | 3200  | 1 |
| MA931M50  | 50  | 81  | 86 | 30 | 135 | 3200  | 1 |
| MA931M54  | 54  | 86  | 86 | 34 | 140 | 3900  | 1 |
| MA931M55  | 55  | 87  | 86 | 34 | 140 | 3900  | 1 |
| MA931M57  | 57  | 86  | 86 | 35 | 150 | 4300  | 1 |
| MA931M58  | 58  | 93  | 86 | 35 | 150 | 4600  | 1 |
| MA931M60  | 60  | 96  | 86 | 35 | 150 | 5150  | 1 |
| MA931M62  | 62  | 97  | 86 | 35 | 150 | 5150  | 1 |
| MA931M65  | 65  | 105 | 86 | 35 | 150 | 5700  | 1 |
| MA931M70  | 70  | 108 | 86 | 35 | 160 | 6700  | 1 |
| MA931M73  | 73  | 110 | 86 | 35 | 170 | 7800  | 1 |
| MA931M75  | 75  | 110 | 86 | 35 | 170 | 7800  | 1 |
| MA931M76  | 76  | 115 | 86 | 35 | 170 | 8200  | 1 |
| MA931M78  | 78  | 116 | 86 | 38 | 170 | 8200  | 1 |
| MA931M80  | 80  | 125 | 86 | 41 | 170 | 8600  | 1 |
| MA931M85  | 85  | 130 | 86 | 44 | 170 | 9900  | 1 |
| MA931M95  | 95  | 137 | 95 | 46 | 180 | 12200 | 1 |
| MA931M100 | 100 | 144 | 95 | 48 | 190 | 14100 | 1 |
| MA931M105 | 105 | 150 | 95 | 51 | 190 | 15800 | 1 |
| MA931M110 | 110 | 156 | 95 | 54 | 200 | 17000 | 1 |
| MA931M115 | 115 | 160 | 95 | 56 | 200 | 20400 | 1 |
| MA931M120 | 120 | 168 | 95 | 58 | 210 | 21500 | 1 |
| MA931M125 | 125 | 168 | 95 | 80 | 210 | 13200 | 1 |

## AD-22/23/24 MAGNETIC ALUMINUM RAIL

48 pieces in one carton



| M7 NO.  | Drive | Total Length | ⚖   | 📦  |    |
|---------|-------|--------------|-----|----|----|
|         | inch  | inch         | mm  | g  |    |
| AD-2212 | 1/4"  | 12"          | 300 | 25 | 10 |
| AD-2312 | 3/8"  | 12"          | 300 | 25 | 10 |
| AD-2412 | 1/2"  | 12"          | 300 | 25 | 10 |
| AD-2218 | 1/4"  | 18"          | 457 | 26 | 10 |
| AD-2318 | 3/8"  | 18"          | 457 | 26 | 10 |
| AD-2418 | 1/2"  | 18"          | 457 | 26 | 10 |

## 3/4" MA641M

### 4 POINT SQUARE IMPACT SOCKET

- 3/4" Drive Deep Length
- 4 Points
- Metric Size



| M7 NO.   | Ø  | D1 | D2 | L  | ⚖   |
|----------|----|----|----|----|-----|
|          | mm | mm | mm | mm | g   |
| MA641M17 | 17 | 37 | 44 | 52 | 320 |
| MA641M19 | 19 | 39 | 44 | 52 | 320 |
| MA641M20 | 20 | 41 | 44 | 52 | 350 |
| MA641M21 | 21 | 42 | 44 | 52 | 350 |

## 3/4" MA641S

### 4 POINT SQUARE IMPACT SOCKET

- 3/4" Drive Deep Length
- 4 Points
- Inch Size



| M7 NO.   | Ø      | D1 | D2 | L  | ⚖   |
|----------|--------|----|----|----|-----|
|          | inch   | mm | mm | mm | g   |
| MA641S24 | 3/4"   | 37 | 44 | 52 | 320 |
| MA641S26 | 13/16" | 39 | 44 | 52 | 320 |

## 3/4" MA643M

### 4 POINT SQUARE IMPACT SOCKET

- 3/4" Drive Deep Length
- 4 Points
- Metric Size



| M7 NO.   | Ø  | D1 | D2 | L  | ⚖   |
|----------|----|----|----|----|-----|
|          | mm | mm | mm | mm | g   |
| MA643M17 | 17 | 37 | 44 | 90 | 600 |
| MA643M19 | 19 | 39 | 44 | 90 | 620 |
| MA643M20 | 20 | 41 | 44 | 90 | 660 |
| MA643M21 | 21 | 42 | 44 | 90 | 670 |
| MA643M22 | 22 | 42 | 44 | 90 | 670 |

## 1" MA841M

### 4 POINT SQUARE IMPACT SOCKET

- 1" Drive Deep Length
- 4 Points
- Metric Size



| M7 NO.   | Ø  | D1 | D2 | L  | ⚖   |
|----------|----|----|----|----|-----|
|          | mm | mm | mm | mm | g   |
| MA841M17 | 17 | 40 | 54 | 57 | 360 |
| MA841M19 | 19 | 43 | 54 | 57 | 360 |
| MA841M20 | 20 | 45 | 54 | 57 | 390 |
| MA841M21 | 21 | 47 | 54 | 57 | 390 |
| MA841M22 | 22 | 47 | 54 | 57 | 390 |

## 1" MA841S

### 4 POINT SQUARE IMPACT SOCKET

- 1" Drive Deep Length
- 4 Points
- Inch Size



| M7 NO.   | Ø      | D1 | D2 | L  | ⚖   |
|----------|--------|----|----|----|-----|
|          | inch   | mm | mm | mm | g   |
| MA841S24 | 3/4"   | 43 | 54 | 57 | 380 |
| MA841S26 | 13/16" | 47 | 54 | 57 | 390 |
| MA841S30 | 15/16" | 48 | 54 | 57 | 430 |

## 1" MA843M

### 4 POINT SQUARE IMPACT SOCKET

- 1" Drive Deep Length
- 4 Points
- Metric Size



| M7 NO.   | Ø  | D1 | D2 | L  | ⚖   |
|----------|----|----|----|----|-----|
|          | mm | mm | mm | mm | g   |
| MA843M17 | 17 | 40 | 54 | 76 | 680 |
| MA843M19 | 19 | 43 | 54 | 76 | 700 |
| MA843M20 | 20 | 45 | 54 | 76 | 720 |
| MA843M21 | 21 | 47 | 54 | 76 | 740 |
| MA843M22 | 22 | 47 | 54 | 76 | 740 |

# IMPACT SOCKET

## ME271M08-7 EXTENSION BIT SOCKET

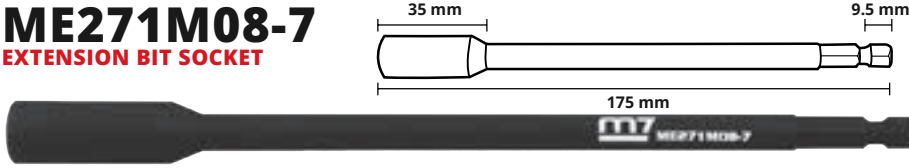

## ME271M10-7 EXTENSION BIT SOCKET

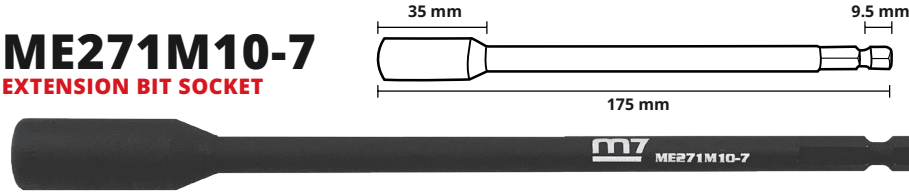

## SOCKET STICKERS PACK

100 pieces in one carton



| M7 NO. | Drive |
|--------|-------|
|        | inch  |
| 8702-1 | 1/4"  |
| 8703-1 | 3/8"  |
| 8704-1 | 1/2"  |
| 8706-1 | 3/4"  |
| 8708-1 | 1"    |



| M7 NO. | Drive |
|--------|-------|
|        | inch  |
| 8702   | 1/4"  |
| 8703   | 3/8"  |
| 8704   | 1/2"  |
| 8706   | 3/4"  |
| 8708   | 1"    |



## 1/2" ME472S

1/2" DRIVE BIT HOLDER  
QUICK CHANGE

| M7 NO.   | Drive | Hex  |     |    |
|----------|-------|------|-----|----|
|          | inch  |      | g   |    |
| ME472S08 | 1/2"  | 1/4" | 118 | 50 |

## Universal Joint

| M7 NO.  | Size   | D  | Total Length |      |      |    |
|---------|--------|----|--------------|------|------|----|
|         | inch   | mm | inch         | mm   | g    |    |
| ME2711  | 1/4"   | 20 | 1-3/4"       | 65   | 42   | 10 |
| ME3711  | 3/8"   | 27 | 2"           | 51   | 102  | 10 |
| ME4711  | 1/2"   | 34 | 2-7/16"      | 61   | 208  | 10 |
| ME6711  | 3/4"   | 49 | 3-1/2"       | 90.4 | 641  | 10 |
| ME6711H | 3/4"   | 49 | 3-1/2"       | 90.4 | 641  | 10 |
| ME8711  | 1"     | 59 | 4-1/2"       | 114  | 1199 | 10 |
| ME8711H | 1"     | 59 | 4-1/2"       | 114  | 1199 | 10 |
| ME9711  | 1-1/2" | 90 | 6-11/16"     | 170  | 1312 | 10 |

## Male Adapter



| M7 NO. | Spec          | D  | L  |      |    |
|--------|---------------|----|----|------|----|
|        | inch          | mm | mm | g    |    |
| ME382  | 3/8"F x 1/4"M | 22 | 32 | 12   | 50 |
| ME384  | 3/8"F x 1/2"M | 22 | 32 | 50   | 50 |
| ME483  | 1/2"F x 3/8"M | 25 | 38 | 65   | 50 |
| ME486  | 1/2"F x 3/4"M | 30 | 48 | 161  | 50 |
| ME486H | 1/2"F x 3/4"M | 30 | 48 | 161  | 50 |
| ME688  | 3/4"F x 1"M   | 46 | 68 | 437  | 50 |
| ME688H | 3/4"F x 1"M   | 46 | 46 | 437  | 50 |
| ME684  | 3/4"F x 1/2"M | 44 | 60 | 343  | 50 |
| ME684H | 3/4"F x 1/2"M | 44 | 60 | 343  | 50 |
| ME886  | 1"F x 3/4"M   | 56 | 80 | 653  | 25 |
| ME886H | 1"F x 3/4"M   | 56 | 80 | 653  | 25 |
| ME889  | 1"F x 1-1/2"M | 54 | 90 | 1078 | 25 |



## DRIVE BIT HOLDER

| M7 NO.   | Drive | Hex   |    |    |
|----------|-------|-------|----|----|
|          | inch  |       | g  |    |
| MB371S08 | 3/8"  | 1/4"  | 43 | 10 |
| MB471S08 | 1/2"  | 1/4"  | 76 | 10 |
| MB471S10 | 1/2"  | 5/16" | 78 | 10 |
| MB471M10 | 1/2"  | 10 mm | 80 | 10 |

## 1/4" ME221 EXTENSION BAR



| M7 NO.   | Total Length |     |    |    |
|----------|--------------|-----|----|----|
|          | inch         | mm  | g  |    |
| ME221-02 | 2"           | 50  | 26 | 10 |
| ME221-04 | 4"           | 100 | 46 | 10 |
| ME221-06 | 6"           | 150 | 67 | 10 |



## 3/8" ME321 EXTENSION BAR

| M7 NO.   | Total Length |     |     |    |
|----------|--------------|-----|-----|----|
|          | inch         | mm  | g   |    |
| ME321-03 | 3"           | 75  | 79  | 10 |
| ME321-05 | 5"           | 125 | 124 | 10 |
| ME321-06 | 6"           | 150 | 140 | 10 |
| ME321-10 | 10"          | 250 | 242 | 10 |
| ME321-12 | 12"          | 300 | 288 | 10 |
| ME321-15 | 15"          | 375 | 354 | 10 |



## 3/8" ME371S

### IMPACT HEX BITS

| M7 NO.   | ⬡     | D2 | L  | ⚖   | 📦   |
|----------|-------|----|----|-----|-----|
|          | inch  | mm | mm | g   |     |
| ME371S06 | 3/16" | 19 | 60 | 50  | 300 |
| ME371S07 | 7/32" | 19 | 60 | 52  | 300 |
| ME371S08 | 1/4"  | 19 | 60 | 70  | 300 |
| ME371S09 | 9/32" | 19 | 60 | 75  | 300 |
| ME371S10 | 5/16" | 19 | 60 | 80  | 300 |
| ME371S12 | 3/8"  | 19 | 60 | 90  | 300 |
| ME371S14 | 7/16" | 19 | 60 | 90  | 300 |
| ME371S16 | 1/2"  | 19 | 60 | 100 | 300 |
| ME371S18 | 9/16" | 19 | 60 | 115 | 300 |
| ME371S20 | 5/8"  | 19 | 60 | 120 | 300 |

## 1/2" ME471M

### IMPACT HEX BIT 1/2" Drive metric size

| M7 NO.   | ⬡  | Total Length | ⚖   | 📦   |
|----------|----|--------------|-----|-----|
|          | mm | mm           | g   |     |
| ME471M04 | 4  | 78           | 71  | 100 |
| ME471M05 | 5  | 78           | 77  | 100 |
| ME471M06 | 6  | 78           | 81  | 100 |
| ME471M07 | 7  | 78           | 87  | 100 |
| ME471M08 | 8  | 78           | 95  | 100 |
| ME471M09 | 9  | 78           | 102 | 100 |
| ME471M10 | 10 | 78           | 108 | 100 |
| ME471M11 | 11 | 78           | 118 | 100 |
| ME471M12 | 12 | 78           | 128 | 100 |
| ME471M13 | 13 | 78           | 140 | 100 |
| ME471M14 | 14 | 78           | 149 | 100 |
| ME471M15 | 15 | 78           | 166 | 100 |
| ME471M16 | 16 | 78           | 177 | 100 |
| ME471M17 | 17 | 78           | 188 | 100 |
| ME471M18 | 18 | 78           | 202 | 100 |
| ME471M19 | 19 | 78           | 215 | 100 |
| ME471M20 | 20 | 78           | 173 | 100 |
| ME471M21 | 21 | 78           | 233 | 100 |
| ME471M22 | 22 | 78           | 194 | 50  |



## 3/8" ME371T

### STAR BIT SOCKET

| M7 NO.   | ★   | D2 | L  | ⚖   | 📦   |
|----------|-----|----|----|-----|-----|
|          | T   | mm | mm | g   |     |
| ME371T10 | T10 | 19 | 60 | 71  | 300 |
| ME371T15 | T15 | 19 | 60 | 71  | 300 |
| ME371T20 | T20 | 19 | 60 | 68  | 300 |
| ME371T25 | T25 | 19 | 60 | 74  | 300 |
| ME371T27 | T27 | 19 | 60 | 76  | 300 |
| ME371T30 | T30 | 19 | 60 | 76  | 300 |
| ME371T40 | T40 | 19 | 60 | 81  | 300 |
| ME371T45 | T45 | 19 | 60 | 85  | 300 |
| ME371T47 | T47 | 19 | 60 | 85  | 300 |
| ME371T50 | T50 | 19 | 60 | 87  | 300 |
| ME371T55 | T55 | 19 | 60 | 106 | 300 |
| ME371T60 | T60 | 19 | 60 | 118 | 300 |
| ME371T70 | T70 | 19 | 60 | 135 | 300 |



## 3/4" ME621

### EXTENSION BAR

• Without Ball : ME621-04H, ME621-06H, ME621-07H, ME621-10H, ME621-13H

| M7 NO.    | Total Length |     | ⚖    | 📦  |
|-----------|--------------|-----|------|----|
|           | inch         | mm  | g    |    |
| ME621-04  | 4"           | 100 | 609  | 10 |
| ME621-04H | 4"           | 100 | 609  | 10 |
| ME621-06  | 6"           | 150 | 813  | 10 |
| ME621-06H | 6"           | 150 | 813  | 10 |
| ME621-07  | 7"           | 175 | 911  | 10 |
| ME621-07H | 7"           | 175 | 911  | 10 |
| ME621-08  | 8"           | 200 | 929  | 10 |
| ME621-10  | 10"          | 250 | 1200 | 10 |
| ME621-10H | 10"          | 250 | 1200 | 10 |
| ME621-13  | 13"          | 330 | 1480 | 10 |
| ME621-13H | 13"          | 330 | 1480 | 10 |



## 3/8" ME371M

### IMPACT HEX BITS

| M7 NO.   | ⬡  | D2 | L  | ⚖   | 📦   |
|----------|----|----|----|-----|-----|
|          | mm | mm | mm | g   |     |
| ME371M04 | 4  | 19 | 60 | 50  | 300 |
| ME371M05 | 5  | 19 | 60 | 50  | 300 |
| ME371M06 | 6  | 19 | 60 | 65  | 300 |
| ME371M07 | 7  | 19 | 60 | 75  | 300 |
| ME371M08 | 8  | 19 | 60 | 80  | 300 |
| ME371M09 | 9  | 19 | 60 | 85  | 300 |
| ME371M10 | 10 | 19 | 60 | 90  | 300 |
| ME371M11 | 11 | 19 | 60 | 90  | 300 |
| ME371M12 | 12 | 19 | 60 | 95  | 300 |
| ME371M13 | 13 | 19 | 60 | 100 | 300 |
| ME371M14 | 14 | 19 | 60 | 110 | 300 |
| ME371M15 | 15 | 19 | 60 | 115 | 300 |
| ME371M16 | 16 | 19 | 60 | 120 | 300 |
| ME371M17 | 17 | 19 | 60 | 150 | 300 |
| ME371M19 | 19 | 19 | 60 | 170 | 300 |

## 1/2" ME471S

### IMPACT HEX BIT 1/2" Drive inch size SAE

| M7 NO.   | ⬡      | Total Length | ⚖   | 📦  |
|----------|--------|--------------|-----|----|
|          | inch   | mm           | g   |    |
| ME471S06 | 3/16"  | 78           | 90  | 10 |
| ME471S07 | 7/32"  | 78           | 90  | 10 |
| ME471S08 | 1/4"   | 78           | 69  | 10 |
| ME471S09 | 9/32"  | 78           | 95  | 10 |
| ME471S10 | 5/16"  | 78           | 94  | 10 |
| ME471S11 | 11/32" | 78           | 100 | 10 |
| ME471S12 | 3/8"   | 78           | 105 | 10 |
| ME471S14 | 7/16"  | 78           | 119 | 10 |
| ME471S16 | 1/2"   | 78           | 134 | 10 |
| ME471S18 | 9/16"  | 78           | 151 | 10 |
| ME471S20 | 5/8"   | 78           | 173 | 10 |
| ME471S22 | 11/16" | 78           | 194 | 10 |
| ME471S24 | 3/4"   | 78           | 215 | 10 |
| ME471S26 | 13/16" | 78           | 229 | 10 |

## 1/2" ME471T

### STAR BIT SOCKET

- 1/2" Drive Deep Length
- 6 Points
- Inch Size

| M7 NO.    | ★    | D2 | L  | ⚖   | 📦 |
|-----------|------|----|----|-----|---|
|           | T    | mm | mm | g   |   |
| ME471T10  | T10  | 25 | 78 | 71  | 1 |
| ME471T15  | T15  | 25 | 78 | 71  | 1 |
| ME471T20  | T20  | 25 | 78 | 68  | 1 |
| ME471T25  | T25  | 25 | 78 | 74  | 1 |
| ME471T27  | T27  | 25 | 78 | 76  | 1 |
| ME471T30  | T30  | 25 | 78 | 76  | 1 |
| ME471T40  | T40  | 25 | 78 | 81  | 1 |
| ME471T45  | T45  | 25 | 78 | 85  | 1 |
| ME471T47  | T47  | 25 | 78 | 85  | 1 |
| ME471T50  | T50  | 25 | 78 | 87  | 1 |
| ME471T55  | T55  | 25 | 78 | 106 | 1 |
| ME471T60  | T60  | 25 | 78 | 118 | 1 |
| ME471T70  | T70  | 25 | 78 | 135 | 1 |
| ME471T80  | T80  | 25 | 78 | 155 | 1 |
| ME471T90  | T90  | 25 | 78 | 155 | 1 |
| ME471T100 | T100 | 25 | 78 | 155 | 1 |

## 1/2" ME421

### EXTENSION BAR

• Without Ball : ME421-05H, MEN421-10H

| M7 NO.    | Total Length |     | ⚖    | 📦  |
|-----------|--------------|-----|------|----|
|           | inch         | mm  | g    |    |
| ME421-03  | 3"           | 75  | 142  | 10 |
| ME421-05  | 5"           | 125 | 228  | 10 |
| ME421-05H | 5"           | 125 | 228  | 10 |
| ME421-10  | 10"          | 250 | 653  | 10 |
| ME421-10H | 10"          | 250 | 653  | 10 |
| ME421-15  | 15"          | 375 | 1041 | 10 |

# IMPACT SOCKET

## 3/4" ME671M

**IMPACT HEX BITS SOCKET**  
3/4" Drive metric size



| M7 NO.   | Size | Total Length |     | g  | g | g |
|----------|------|--------------|-----|----|---|---|
|          |      | mm           | mm  |    |   |   |
| ME671M10 | 10   | 100          | 490 | 35 |   |   |
| ME671M12 | 12   | 100          | 510 | 35 |   |   |
| ME671M14 | 14   | 100          | 520 | 35 |   |   |
| ME671M17 | 17   | 100          | 540 | 35 |   |   |
| ME671M19 | 19   | 100          | 600 | 35 |   |   |
| ME671M21 | 21   | 100          | 610 | 25 |   |   |
| ME671M22 | 22   | 100          | 620 | 25 |   |   |
| ME671M24 | 24   | 100          | 690 | 25 |   |   |
| ME671M27 | 27   | 100          | 720 | 20 |   |   |
| ME671M30 | 30   | 100          | 830 | 20 |   |   |
| ME671M32 | 32   | 100          | 850 | 20 |   |   |

## 3/4" ME671S

**IMPACT HEX BITS SOCKET**  
3/4" Drive inch size

| M7 NO.   | Size    | Total Length |     | g  | g | g |
|----------|---------|--------------|-----|----|---|---|
|          |         | inch         | mm  |    |   |   |
| ME671S12 | 3/8"    | 100          | 480 | 35 |   |   |
| ME671S14 | 7/16"   | 100          | 500 | 35 |   |   |
| ME671S16 | 1/2"    | 100          | 510 | 35 |   |   |
| ME671S18 | 9/16"   | 100          | 520 | 35 |   |   |
| ME671S20 | 5/8"    | 100          | 530 | 35 |   |   |
| ME671S22 | 11/16"  | 100          | 540 | 35 |   |   |
| ME671S24 | 3/4"    | 100          | 600 | 30 |   |   |
| ME671S26 | 13/16"  | 100          | 610 | 30 |   |   |
| ME671S28 | 7/8"    | 100          | 620 | 30 |   |   |
| ME671S30 | 15/16"  | 100          | 690 | 30 |   |   |
| ME671S32 | 1"      | 100          | 680 | 25 |   |   |
| ME671S34 | 1-1/16" | 100          | 720 | 15 |   |   |
| ME671S36 | 1-1/8"  | 100          | 740 | 15 |   |   |
| ME671S38 | 1-3/16" | 100          | 830 | 10 |   |   |
| ME671S40 | 1-1/4"  | 100          | 850 | 10 |   |   |

## 1" ME871M

**IMPACT HEX BITS SOCKET**



| M7 NO.   | Size | Total Length |     | g  | g | g |
|----------|------|--------------|-----|----|---|---|
|          |      | mm           | mm  |    |   |   |
| ME871M10 | 10   | 78           | 71  | 10 |   |   |
| ME871M12 | 12   | 78           | 77  | 10 |   |   |
| ME871M14 | 14   | 78           | 81  | 10 |   |   |
| ME871M17 | 17   | 78           | 87  | 10 |   |   |
| ME871M19 | 19   | 78           | 95  | 10 |   |   |
| ME871M22 | 22   | 78           | 102 | 10 |   |   |
| ME871M24 | 24   | 78           | 108 | 10 |   |   |
| ME871M27 | 27   | 78           | 118 | 10 |   |   |
| ME871M30 | 30   | 78           | 128 | 10 |   |   |
| ME871M32 | 32   | 78           | 140 | 10 |   |   |

## 1" ME821

**EXTENSION BAR**

• Without Ball : ME821-07H, ME821-10H, ME821-13H



| M7 NO.    | Total Length |     | g    | g  | g |
|-----------|--------------|-----|------|----|---|
|           | inch         | mm  |      |    |   |
| ME821-03  | 3"           | 75  | 727  | 10 |   |
| ME821-06  | 6"           | 150 | 1330 | 10 |   |
| ME821-07  | 7"           | 175 | 1520 | 10 |   |
| ME821-07H | 7"           | 175 | 1520 | 10 |   |
| ME821-08  | 8"           | 200 | 1705 | 10 |   |
| ME821-10  | 10"          | 250 | 2050 | 6  |   |
| ME821-10H | 10"          | 250 | 2050 | 6  |   |
| ME821-12  | 12"          | 300 | 2382 | 6  |   |
| ME821-13  | 13"          | 330 | 2550 | 6  |   |
| ME821-13H | 13"          | 330 | 2550 | 6  |   |

## ME4050

**EXTENSION BAR**

• Contents :  
• ME422-090, ME422-110, ME422-122,  
ME422-137, ME422-151



## 1/2" ME904

**1/2" DRIVE LOCKING RING**  
**1/2" DRIVE LOCKING PIN**

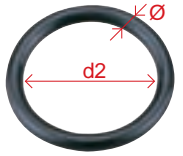

| M7 NO.  | Desp. | Ø   | d2 | ℓ  | Applied to socket sizes |
|---------|-------|-----|----|----|-------------------------|
|         |       | mm  | mm | mm |                         |
| ME90424 | Ring  | 3.5 | 19 |    | 8~19mm                  |
| ME90424 | Pin   | 3   |    | 20 | (3/16"~9/16")           |
| ME90436 | Ring  | 3.5 | 23 |    | 15~46mm                 |
| ME90436 | Pin   | 3   |    | 25 | (5/8"~1-1/4")           |

## 3/4" ME906

**3/4" DRIVE LOCKING RING**  
**3/4" DRIVE LOCKING PIN**

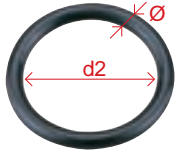

| M7 NO.  | Desp. | Ø   | d2 | ℓ  | Applied to socket sizes |
|---------|-------|-----|----|----|-------------------------|
|         |       | mm  | mm | mm |                         |
| ME90627 | Ring  | 3.5 | 33 |    | 17~30mm                 |
| ME90627 | Pin   | 3   |    | 30 | (11/16"~1-3/16")        |
| ME90646 | Ring  | 5.5 | 37 |    | 17~46mm                 |
| ME90646 | Pin   | 4   |    | 35 | (1-1/16"~1-13/16")      |
| ME90650 | Ring  | 5.5 | 44 |    | 48mm~65mm               |
| ME90650 | Pin   | 4   |    | 45 | (1-7/8"~2-3/8")         |

## 1" ME908

**1" DRIVE LOCKING RING**  
**1" DRIVE LOCKING PIN**

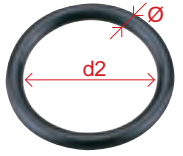

| M7 NO.  | Desp. | Ø   | d2 | ℓ  | Applied to socket sizes |
|---------|-------|-----|----|----|-------------------------|
|         |       | mm  | mm | mm |                         |
| ME90836 | Ring  | 5.5 | 48 |    | 19~70mm                 |
| ME90836 | Pin   | 5   |    | 45 | (3/4"~2-3/4")           |
| ME90860 | Ring  | 10  | 75 |    | 71~90mm                 |
| ME90860 | Pin   | 5   |    | 75 | (2-13/16"~3-1/2")       |

## ME422

**EXTENSION BAR**

1/2" Drive torque



| M7 NO.    | Color      | Total Length |      | D       | Torque | g  | g |
|-----------|------------|--------------|------|---------|--------|----|---|
|           |            | mm           | mm   |         |        |    |   |
| ME422-090 | Yellow     | 194          | 9    | 65/90   | 236    | 10 |   |
| ME422-110 | Blue       | 194          | 11   | 80/110  | 231    | 10 |   |
| ME422-122 | Gray       | 194          | 12.2 | 100/135 | 258    | 10 |   |
| ME422-137 | White      | 194          | 13.7 | 120/160 | 300    | 10 |   |
| ME422-151 | Sky nature | 194          | 15.1 | 140/190 | 306    | 10 |   |
| ME422-103 | Black      | 194          | 10.3 | 75/100  | 224    | 10 |   |
| ME422-114 | Beige      | 194          | 11.4 | 90/120  | 242    | 10 |   |
| ME422-128 | Orange     | 194          | 12.8 | 110/150 | 269    | 10 |   |

# AFTER MARKET SUPPORT

## AD-3511P AD-3511T

Display security steel wire rope

Hook type base

**HOOK TYPE BASE WITH CARD DISPLAY  
& DISPLAY SECURITY STEEL WIRE ROPE**

Contents :



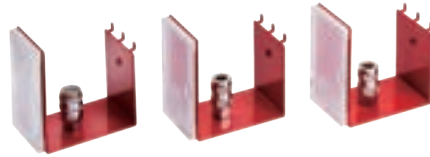







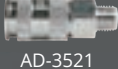

- AD-3511P :
- 1 x Display security steel wire rope
- 2 x L Hex wrench
- 1 x Hex socket screws
- AD-3511T :
- 1 x Acrylic card case hook type base



AD-3511P



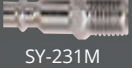
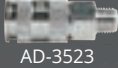





AD-3511T

| Item No.   | Adaptor Type | Contents   |  |  |   |
|--|--------------|--|--|--|---|
|  AD-3511  | Europe       |  SY-211M  |  AD-3521  |   |  AD-3511T  |
|  AD-3512  | Japan        |  SY-221M  |  AD-3522  |   |  AD-3511T  |
|  AD-3513 | U.S.A        |  SY-231M |  AD-3523 |  |  AD-3511T |















## AD-35

COMPLETE SET OF TOOL BASE

| Item No.  | Adaptor Type | Contents  |  |   |  |
|---|--------------|---|--|---|--|
|  AD-3501 | Europe       |  SY-211M |  AD-3521 |  |  AD-351 |
|  AD-3502 | Japan        |  SY-221M |  AD-3522 |  |  AD-351 |
|  AD-3501 | U.S.A        |  SY-231M |  AD-3521 |  |  AD-351 |

## AD-36

COMPLETE SET OF TOOL BASE

| Item No.   | Adaptor Type | Contents  |   |   |   |
|--|--------------|---|---|---|---|
|  AD-3601 | Europe       |  SY-211M |  AD-3521 |  |  AD-305-41 |
|  AD-3602 | Japan        |  SY-221M |  AD-3522 |  |  AD-305-41 |
|  AD-3601 | U.S.A        |  SY-231M |  AD-3521 |  |  AD-305-41 |

# AFTER MARKET SUPPORT

## AD-309 DISPLAY BOARD

1 pieces in one carton

- Nice m7 brand image is conducive to small space display hanging tools.
- Can also be used as a gift to the user to hang the tools.

Overall Size(mm)  
Width x Depth x Height

725 x 14 x 900  
weight : 11.5 kg

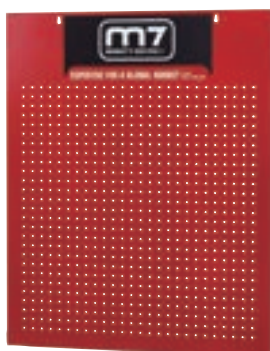

## AD-307 WALL TYPE DISPLAY STAND

- Powder Coating
- Attachment
- 1pc Brand Plate
- 2pcs Angled Steel Frame
- 2pcs Shelf
- 1pc Bottom Shelf
- 4pcs Steel Plate With Hole

Overall Size(mm)  
Width x Depth x Height

900 x 500 x 2230

## AD-303-41 Hooks



## AD-351 OPTIONAL ITEM

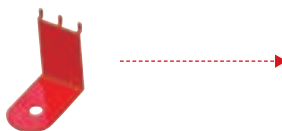

## AD-361 OPTIONAL ITEM

Overall Size(mm)  
Width x Depth

280 x 910

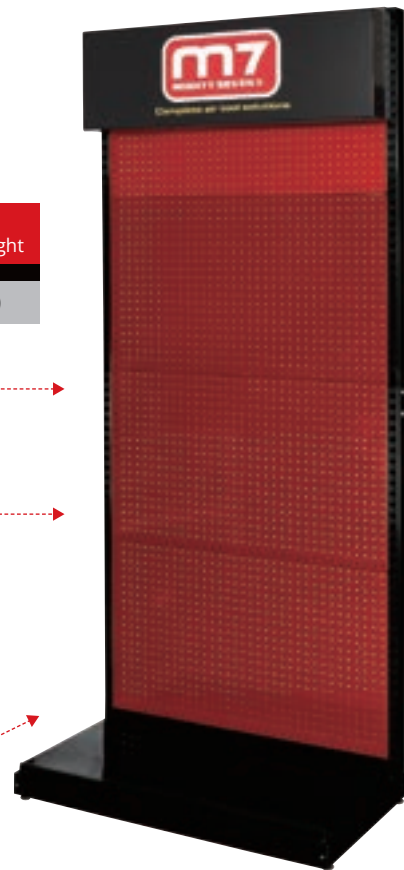

## AD-308 TOWER TYPE DISPLAY STAND

- 1pc Transparent DM Shelf
- 2pcs Support Frame
- 1pc Bottom Shelf

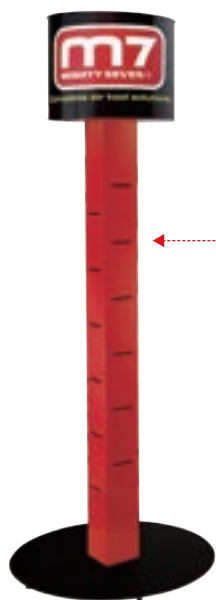

## AD-305-41 OPTIONAL ITEM

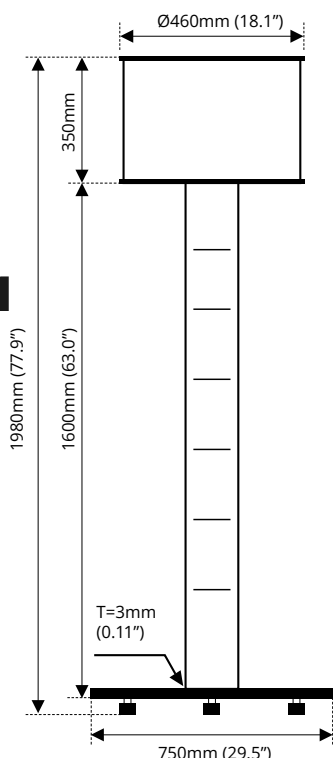

## ST-10C521 ST-10C522S

USER DIY ASSEMBLED MOBILE WORKING CHAIR

- Color : red/black anti scratch paint
- Seat cushion materials : high graded artificial PVC leather with sponge
- Product sizes : long 350mm width 260mm height 240mm, excl.
- Wheels drawer height : 70mm
- Product feature : storage daily needed tools reduce squatting fatigue, movable willingly.



ST-10C521



ST-10C522  
1 Drawer Design

| Contains                   | Package    |              |         |       |
|----------------------------|------------|--------------|---------|-------|
|                            | Net Weight | Gross Weight | Length  | Width |
|                            | kg         | kg           | mm      | mm    |
| Lamp Case Set              | 4.35       | 5.35         | 530 510 | 101   |
| Display Pillar             | 8.0        | 9.0          | 930 330 | 180   |
| Display Stand Bottom Plate | 10.45      | 11.45        | 810 820 | 70    |

# DISPLAY CASE

## SF-306/SF-604/SF-605

### SPARE PARTS BOX

- greasy-resisting
- wearproof

|        | Overall Size(mm)<br>Width x Depth x Height |
|--------|--|
| SF-306 | 303 x 106 x 253 (11.8"x4.1"x1")            |
| SF-604 | 603 x 167 x 203 (23.7"x6.5"x8")            |
| SF-605 | 603 x 123 x 153 (23.7"x4.8"x6")            |



SF-306



SF-604



SF-605

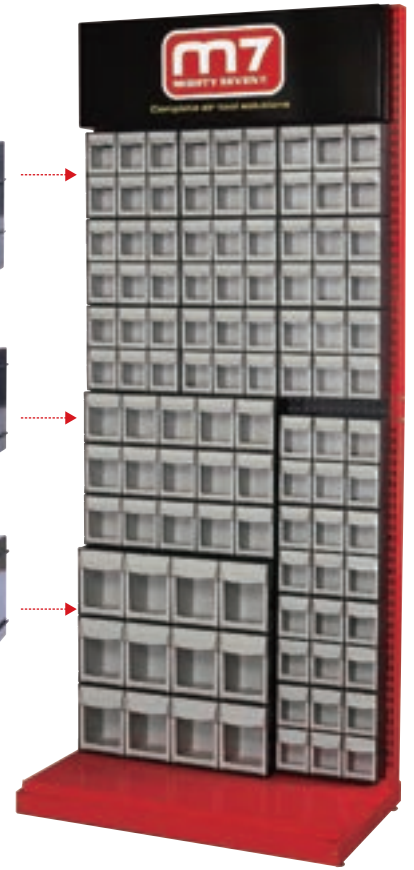

## AD-306

### TABLE TYPE DISPLAY STAND

- 1 pc Transparent DM shelf
- 2 pcs support frame
- 1 pc Bottom shelf
- 3 set (AD-3521/3522/3523)

Overall Size(mm)  
Width x Depth x Height

300 x 140 x 340



## AD-306DB

### TABLE DISPLAY FOR CORDLESS TOOL



## AD-101

### CORDLESS TOOLS DISPLAY



## AD-431

### 1/2" DR. SOCKET SHELF SET



## AD-201

### 1/2" DR. SOCKET SHELF SET



## SH-1001

### AIR TOOL HOLDER



## ACCESSORIES

## ZT-13-1 Forward ZT-13-2 Reverse

### TORQUE TEST MACHINE

Torque testing for maintaining pneumatic impact wrenches

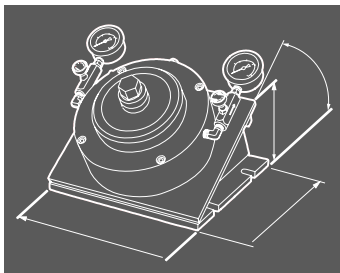

- Applicable Range : 50ft-lb~2000ft-lb(70Nm~2700Nm)
- Max. Torque : 3500 ft-lb(5000Nm)
- Applicable Size : SQ-DR-1/2"~3/4"
- Measuring Direction : ZT-13-1 Forward/ZT-13-2 Reverse
- Screw Size : M32
- Length x Width : 35cm x 30cm
- Weight : 49KG



# ACCESSORIES



## NON-VACCUM VELCRO

Backing Face : velcro



| ITEM NO. | SIZE | Max R.P.M |
|----------|------|-----------|
| QB-9302  | 2"   | 15000     |
| QB-9303  | 3"   | 15000     |
| QB-9305  | 5"   | 12000     |
| QB-9306  | 6"   | 12000     |

Blister+Card



## SIX HOLE

Backing Face : velcro  
velcro & vinyl are both available



| ITEM NO.         | SIZE | Max R.P.M |
|------------------|------|-----------|
| QB-9315 (velcro) | 5"   | 12000     |
| QB-9355 (vinyl)  | 5"   | 10000     |
| QB-9316 (velcro) | 6"   | 12000     |
| QB-9356 (vinyl)  | 6"   | 12000     |

Blister+Card



## NON-VACCUM VINYL

Backing Face : vinyl



| ITEM NO. | SIZE | Max R.P.M |
|----------|------|-----------|
| QB-9345  | 5"   | 12000     |
| QB-9346  | 6"   | 12000     |

Blister+Card



## FIFTEEN HOLE

Backing Face : velcro  
velcro & vinyl are both available

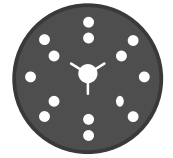

| ITEM NO.         | SIZE | Max R.P.M |
|------------------|------|-----------|
| QB-9327 (velcro) | 6"   | 12000     |
| QB-9366 (vinyl)  | 6"   | 12000     |

Blister+Card



## QB-922

2" Roll On Holder



## QB-923

3" Roll On Holder



| ITEM NO. | Size | Max R.P.M | For M7 Item No.  |
|----------|------|-----------|------------------|
| QB-922   | 2"   | 30,000    | QP-212<br>QP-213 |
| QB-923   | 3"   | 20,000    | QP-223<br>QB-625 |

## QB-9802 QB-9803

Stripping Disc



| ITEM NO. | SIZE | R.P.M  |
|----------|------|--------|
| QB-9802  | 2"   | 15,000 |
| QB-9803  | 3"   | 15,000 |

## QB-9712K QB-9713K

Stripping Disc  
Use on QB-922 & QB-923  
Roll-on holder



5 pcs / 1 SET

| ITEM NO. | SIZE | R.P.M  |
|----------|------|--------|
| QB-9712K | 2"   | 15,000 |
| QB-9713K | 3"   | 15,000 |



Bag+Card

# QB-9337M QB-9337S

7" Sanding Pad



| ITEM NO. | Size | Max R.P.M | Thread Size | For M7 Item No.  |
|----------|------|-----------|-------------|------------------|
| QB-9337M | 7"   | 15,000    | M14 x 2.0   | QB-307<br>QB-327 |
| QB-9337S | 7"   | 15,000    | 5/8" x 11   | QB-317           |

# PAD DIE Series

5 pcs / 1 SET

Use on QB-922 & QB-923



Blister+Card



| ITEM NO.     | Size | PS.       | Max R.P.M | For M7 Item NO.                        |
|--------------|------|-----------|-----------|--|
| QB-9702k-24  | 2"   | Grit:#24  | 30,000    | QP-212<br>QP-212N<br>QB-625<br>QB-0618 |
| QB-9702k-40  |      | Grit:#40  |           |  |
| QB-9702k-60  |      | Grit:#60  |           |  |
| QB-9702k-80  |      | Grit:#80  |           |  |
| QB-9702k-100 |      | Grit:#100 |           |  |
| QB-9702k-120 |      | Grit:#120 |           |  |
| QB-9702k-150 |      | Grit:#150 |           |  |
| QB-9702k-180 |      | Grit:#180 |           |  |
| QB-9702k-240 |      | Grit:#240 |           |  |
| QB-9703k-24  | 3"   | Grit:#24  | 25,000    |  |
| QB-9703k-40  |      | Grit:#40  |           |  |
| QB-9703k-60  |      | Grit:#60  |           |  |
| QB-9703k-80  |      | Grit:#80  |           |  |
| QB-9703k-100 |      | Grit:#100 |           |  |
| QB-9703k-120 |      | Grit:#120 |           |  |
| QB-9703k-150 |      | Grit:#150 |           |  |
| QB-9703k-180 |      | Grit:#180 |           |  |
| QB-9703k-320 |      | Grit:#320 |           |  |

# PAD DIE Series

5 pcs / SET

Use on QB-922 & QB-923



Blister+Card



| ITEM NO.   | Size | PS.               | Max R.P.M | For M7 Item NO.                        |
|------------|------|-------------------|-----------|--|
| QB-9712-YL | 2"   | Yellow-Coarse #80 | 30,000    | QP-212<br>QP-212N<br>QB-625<br>QB-0618 |
| QB-9712-RD | 2"   | Red-Medium #150   |           |  |
| QB-9712-BL | 2"   | Blue-Fine #300    |           |  |
| QB-9713-YL | 3"   | Yellow-Coarse #80 |           |  |
| QB-9713-RD | 3"   | Red-Medium #150   |           |  |
| QB-9713-BL | 3"   | Blue-Fine #300    |           |  |

# QB-801/QB-9401

Eraser Wheel / Wire Wheel



# QB-9434 FOR GLOBAL QB-9434U FOR USA ONLY

Eraser Wheel  
Available with QB-812T



# QB-9444 FOR GLOBAL QB-9444U FOR USA ONLY

Eraser Wheel  
Available with QB-802 & QB-812



# ACCESSORIES

## QB-95 SERIES

Wool Bonnet PAD



Bag+Card



| ITEM NO. | Size | PS.       | For M7 Item NO. |
|----------|------|-----------|-----------------|
| 0QB-9512 | 2"   | Velcro    | QB-9302         |
| 0QB-9513 | 3"   | Velcro    | QB-9303         |
| 0QB-9515 | 5"   | Velcro    | QB-9305         |
| 0QB-9517 | 7"   | Velcro    | QB-9315         |
| 0QB-9507 | 7"   | Tie Cords |                 |

## QB-94 SERIES

Sponge



Bag+Card

| ITEM NO. | Size | PS.            | Thickness | For M7 Item NO.   |
|----------|------|----------------|-----------|---|
| 0QB-9402 | 2"   | Yellow / Rough | 25mm      | QB-9302<br>QB-9303<br>QB-9305<br>QB-9306<br>QB-9315<br>QB-9316<br>QB-9327 |
| 0QB-9422 | 2"   | White / Medium | 25mm      |   |
| 0QB-9403 | 3"   | Yellow / Rough | 25mm      |   |
| 0QB-9413 | 3"   | White / Medium | 25mm      |   |
| 0QB-9404 | 4"   | Yellow / Rough | 25mm      |   |
| 0QB-9414 | 4"   | White / Medium | 25mm      |   |
| 0QB-9405 | 5"   | Yellow / Rough | 25mm      |   |
| 0QB-9415 | 5"   | White / Medium | 25mm      |   |
| 0QB-9406 | 6"   | Yellow / Rough | 25mm      |   |
| 0QB-9416 | 6"   | White / Medium | 25mm      |   |
| 0QB-9407 | 7"   | Yellow / Rough | 25mm      |   |
| 0QB-9417 | 7"   | White / Medium | 25mm      |   |

## QB-9320

PAD

FOR QK-111 QK-121

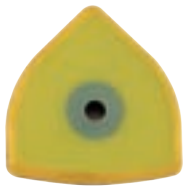

## QB-9323

3" Sanding Pad



## QB-9211A/B [SET]

Grinder Stone Set  
A(3mm shank)B(1/8" shank)

Available with  
QA-633Q, QA-611, QA-632Q, QA-111, QA-211, QA-231Q,  
QA-311, QA-313, QA-315



Blister+Card

## QB-911 [SET] QB-912 [SET]

Abrasive Cloth Belt

QB-91108  
QB-91208  
Available with  
For QB-311 / QB-321

QB-91110  
QB-91210  
Available with  
For QB-312 / QB-322 / QB-322C



Blister+Card

## QB-9213A/B [SET]

Grinder Stone Set  
A(6mm shank)B(1/4" shank)

Available with  
M7 All Air Die Grinder





Blister+Card

| ITEM NO. | Belt Size         |   | For M7 Item NO.             |
|----------|-------------------|---|-----------------------------|
| QB-91108 | 10mm x 330mm #80  | 10Pcs/1 Set   | QB-311<br>QB-321            |
| QB-91110 | 10mm x 330mm #100 | 10Pcs/1 Set   |                             |
| QB-91208 | 20mm x 520mm #80  | 10Pcs/1 Set   | QB-322<br>QB-322C<br>QB-312 |
| QB-91210 | 20mm x 520mm #100 | 10Pcs/1 Set   |                             |

## QB-904/QB-905/QB-907

Grinding Wheel Materials: Aluminum Oxide



| ITEM NO. | Specification                             |   | For M7 Item NO.   |
|----------|---|---|---|
| 0QB-904  | 100 x 6 x 16<br>4" x 1/4" x 5/8"<br>102mm | 25 / 200  | (QB-904) :<br>QB-104, QB-114, QB-124, QB-134,<br>QB-144, QB-154, QB-164, QB-194,<br>QB-194N, QB-194L, QB-7114 |
| 0QB-905  | 125 x 6 x 22<br>5" x 1/4" x 7/8"<br>127mm | 25 / 200  | (QB-905) :<br>QB-115, QB-125, QB-135, QB-145,<br>QB-155, QB-165, QB-185, QB-195,<br>QB-7115                   |
| 0QB-907  | 180 x 6 x 22<br>7" x 1/4" x 7/8"<br>128mm | 25 / 200  | (QB-907) :<br>QB-107, QB-117, QB-177, QB-187,<br>QB-197   |

## QD-932P

32T Saw Blade Bi-Metal Material

Available with  
QD-221 & QD-291

10 pcs / box

Blister+Card



## QD-905P

4 Pieces File Set clamshell pack  
For QD-291 / 230  
Blister+Card

20 pieces in one carton

Ø5.0mm



## QM-901

Universal repairing kit for  
Auto-Transmission shaft boot



Available with QM-1125



## QB-913/QB-914

Cut-off Wheel



| ITEM NO. | Specification                                |   | For M7 Item NO.                     |
|----------|--|---|-------------------------------------|
| 0QB-913  | 75 x 1.5 x 10<br>3" x 1/16" x 3/8"<br>76mm   | 25 / 200  | QC-213 / QC-213T / QC-253           |
| 0QB-914  | 100 x 1.5 x 10<br>4" x 1/16" x 3/8"<br>102mm | 25 / 200  | QC-213 / QC-213T / QC-253<br>QC-264 |

## QD-924P

24T Saw Blade Bi-Metal Material

Available with  
QD-221 & QD-291

10 pcs / box



Blister+Card

## QD-906P

5 Pieces File Set clamshell pack  
For QD-221  
Blister+Card

20 pieces in one carton

Ø4.0mm



Blister+Card

## PC-901

Adjustable Toeque Air Tapping Adapter

HEX:8mm

For : Air Drill / Electricity Drill / Cordless Drill / Drill Machine

Blister+Card



# ACCESSORIES

## SN-9101/SN-9103 SN-9201/SN-9203

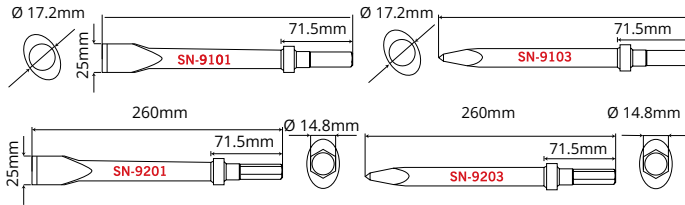

## SW-12(1/4") SW-13(3/8")

Mini Lubricator  
Install on the air inlet to provide automatic lubrication 8c.c. lubricating oil capacity



Box

Blister

## PA-MC

Automatic Mandrel Collection

3/32" (2.4mm) 220pcs  
1/8" (3.2mm) 160pcs  
5/32" (4.0mm) 110pcs  
3/16" (4.8mm) 80pcs



## PE-MC

Standard Safety Tip



## SB-902

0-90° Angle Adjustable  
One Touch Chuck Adaptor

Available with SB Series TYRE INFLATOR



## SB-912

0-90° Angle Adjustable  
One Touch Chuck Adaptor

Available with SB Series TYRE INFLATOR



## SC-2B

Quick Change Retainer

Available with  
For SC-21 / SC-22 / SC-31 /  
SC-34 SERIES



## SC-2A

Retainer



## MA-412M1719



Double Sided Socket  
2" Extended Anvil matching special  
double sided socket 17mm & 19mm  
specifically for automotive tyres.

## MA-412M2122



Double Sided Socket  
2" Extended Anvil matching special  
double sided socket 21mm & 22mm  
specifically for automotive tyres.

## MA-412S2426



Double Sided Socket  
2" Extended Anvil matching special  
double sided socket 24mm & 26mm  
specifically for automotive tyres.

## SZ-212A

### AIR REGULATOR

#### FEATURES

- Used to adjust the air inlet flow of pneumatic tools
- Easy to mount

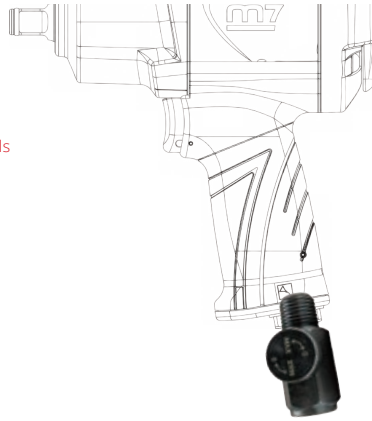

## SN-124/SN-268 SN-128/SN-288



#### Needle Set

- SN-288
- (12 Needle Set) 3 x 125mm
- Available with
- SN-1288
- SN-124
- (24 Needle Set) 3 x 180mm
- Available with
- SN-2124
- SN-268
- (19 Needle Set) 3 x 180mm
- Available with
- SN-1268 / 2110 / 1368
- SN-128
- (28 Needle Set) 3 x 180mm
- Available with
- SN-2128

## SO-10

### Lubrication



## SG-101

### Lubrication Kit



## SO-10T

### Lubrication Kit



BOX

## NC-REPAIR KIT

### Replacement Parts



## NE-REPAIR KIT

### Replacement Parts



## QK-Series

### Air Knife Blade

For QK-111 / QK-121 / QK-131 / PN-250 / PN-280

QK-111P51

QK-111P52

QK-111P53

QK-111P54

QK-111P50



QK-111P08

QK-2090

QK-2063

QK-2036



#### Blister

0QK-2030P - QK-111P08

0QK-1057P - QK-111P50

0QK-3018P - QK-111P51

0QK-3036P - QK-111P52

0QK-1008P - QK-111P54

# ACCESSORIES

## SC-415P CHISEL SET SC-425P CHISEL SET

SC-415 - Chisel Set / 175mmL / Round  
SC-425 - Chisel Set / 175mmL / Hex

Available with  
SC-331C / SC-341C / SC-332C / SC-342C / SC-211C /  
SC-221C / SC-212C / SC-222C



Flat Chisel  
SC-4101 Round / SC-4201 Hex



Cutting Chisel  
SC-4102 Round / SC-4202 Hex



Tapered Punch  
SC-4103 Round / SC-4203 Hex



Ripping Chisel  
SC-4104 Round / SC-4204 Hex



Tail Pipe Cutter  
SC-4105 Round / SC-4205 Hex

## CHISEL

For SN-31 / SN-32 SERIES



Blister+Card

## QB-9773K19

3" Polishing Sponge Kit  
MAX : 15,000 R.P.M

For QP-113 / QP-123 / QP-213 / QP-223



**SHANK TYPE**  
QB-9773K19A : 6mm  
QB-9773K19B : 1/4"

**CONTENTS :**  
Shank x 1 PC (A or B)  
3" Sanding Pad x 1PC  
3" Sanding Sponge x 6PCS  
3" Sanding Paper x 10PCS  
3" Polishing Sponge x 2PCS

Blister+Card

## QB-9752K07

2" Felt Pad Conditioning Disc Kit  
MAX : 20,000 R.P.M

For QP-113 / QP-123 / QP-213 / QP-223



**SHANK TYPE**  
QB-9752K07A : 6mm  
QB-9752K07B : 1/4"

**CONTENTS :**  
2" Felt Pad x 6PCS

Blister+Card

## QB-9762K07

2" Surface Pad Conditioning Disc Kit  
MAX : 20,000 R.P.M

For QP-113 / QP-123 / QP-213 / QP-223



**SHANK TYPE**  
QB-9762K07A : 6mm  
QB-9762K07B : 1/4"

**CONTENTS :**  
Shank x 1 PC (A or B)  
2" Stripping Disc x 2PCS

**2" CONDITIONING DISC :**  
Red x 2PCS  
Grey x 2PCS

Blister+Card

## QB-9742K20

2" Surface Sanding Kit  
MAX : 30,000 R.P.M

For QP-212 / QP-213 / QP-223 / QB-625



**SHANK TYPE**  
QB-9742K20A : 6mm  
QB-9742K12B : 1/4"

**CONTENTS :**  
Shank x 1 PC (A or B)  
2" Rollon Holder x 1PC  
2" Pad Die x 15PCS  
2" Sanding Disc x 3PCS

Blister+Card

## QB-9742K12

2" Surface Sanding Kit  
MAX : 30,000 R.P.M

For QP-212 / QP-213 / QP-223 / QB-625



**CONTENTS :**  
Shank x 1 PC (A or B)  
2" Rollon Holder x 1PC  
2" Pad Die x 6PCS  
2" Sanding Disc x 3PCS  
2" Stripping Disc x 1PC

Blister+Card

## QB-9743K12

3" Surface Sanding Kit  
MAX : 20,000 R.P.M

For QP-212 / QP-213 / QP-223 / QB-625



**SHANK TYPE**  
QB-9743K12A : 6mm  
QB-9743K12B : 1/4"

**CONTENTS :**  
Shank x 1 PC (A or B)  
3" Rollon Holder x 1PC  
3" Pad Die x 6PCS  
3" Sanding Disc x 3PCS  
3" Stripping Disc x 1PC

Blister+Card

## QB-9303K04

3" Sander / Buffer Versatility Kit

Thread : 5/16" x 24

MAX : 15,000 R.P.M

For QP-113 / QP-123 / QP-213 / QP-223



Blister+Card

### CONTENTS :

- 3" Sanding Pad x 1PC
- 3" Foam Yellow x 1PC
- 3" Foam White x 1PC
- 3" Wool Bonnet x 1PC
- Max R.P.M : 15,000
- Backing Face :  
Velcro Available

## QB-974K12

2" & 3" Surface Sanding Kit

2" Max : 30,000 R.P.M

3" Max : 20,000 R.P.M

For QP-212 / QP-213 / QP-223 / QB-625



Blister+Card

### SHANK TYPE

- QB-974K12A : 6mm
- QB-974K12B : 1/4"

### CONTENTS :

- Shank x 2 PC (A or B)
- 2" Rollon Holder x 1PC
- 3" Rollon Holder x 1PC
- 2" Sanding Disc x 4PCS
- 3" Sanding Disc x 4PCS

## QB-9743K20

3" Surface Sanding Kit

MAX : 20,000 R.P.M

For QP-212 / QP-213 / QP-223 / QB-625



Blister+Card

### SHANK TYPE

- QB-9743K20A : 6mm
- QB-9743K20B : 1/4"

### CONTENTS :

- Shank x 1 PC (A or B)
- 3" Rollon Holder x 1PC
- 3" Pad Die x 15PCS
- 3" Sanding Disc x 3PCS

## QB-9933V

Velcro Triangular Sandpaper Set



## SANDING PAPER SERIES

Velcro / Self-Adhesive  
Six hole / Non-Vacuum

5 pcs or 10 pcs / 1 SET



### Self-Adhesive

| ITEM NO.        | Size | PS.       | Velcro / Self-AD | For M7 Item NO. | Holes | pcs / set |
|-----------------|------|-----------|------------------|-----------------|-------|-----------|
| 0QB-9913S-08K10 | 3"   | Grit:#80  | Self-Adhesive    | QP-113          | Non   | 10        |
| 0QB-9913S-15K10 |      | Grit:#150 |                  |                 |       |           |
| 0QB-9913S-18K10 |      | Grit:#180 |                  |                 |       |           |
| 0QB-9913S-32K10 |      | Grit:#320 |                  |                 |       |           |
| 0QB-9913S-40K10 |      | Grit:#400 |                  |                 |       |           |
| 0QB-9915S-08K5  | 5"   | Grit:#80  |                  | QB-41           |       |           |
| 0QB-9915S-15K5  |      | Grit:#150 |                  |                 |       |           |
| 0QB-9915S-18K5  |      | Grit:#180 |                  |                 |       |           |
| 0QB-9915S-32K5  |      | Grit:#320 |                  |                 |       |           |
| 0QB-9915S-40K5  |      | Grit:#400 |                  |                 |       |           |
| 0QB-9916S-08K5  | 6"   | Grit:#80  | QB-42            |                 |       |           |
| 0QB-9916S-15K5  |      | Grit:#150 |                  |                 |       |           |
| 0QB-9916S-18K5  |      | Grit:#180 |                  |                 |       |           |
| 0QB-9916S-32K5  |      | Grit:#320 |                  |                 |       |           |
| 0QB-9916S-40K5  |      | Grit:#400 |                  |                 |       |           |
| 0QB-9905S-08K5  | 5"   | Grit:#80  | QB-43            | 6               | 5     |           |
| 0QB-9905S-15K5  |      | Grit:#150 |                  |                 |       |           |
| 0QB-9905S-18K5  |      | Grit:#180 |                  |                 |       |           |
| 0QB-9905S-32K5  |      | Grit:#320 |                  |                 |       |           |
| 0QB-9905S-40K5  |      | Grit:#400 |                  |                 |       |           |
| 0QB-9906S-08K5  | 6"   | Grit:#80  | QB-45            | 6               | 5     |           |
| 0QB-9906S-15K5  |      | Grit:#150 |                  |                 |       |           |
| 0QB-9906S-18K5  |      | Grit:#180 |                  |                 |       |           |
| 0QB-9906S-32K5  |      | Grit:#320 |                  |                 |       |           |
| 0QB-9906S-40K5  |      | Grit:#400 |                  |                 |       |           |

### Velcro

| ITEM NO.        | Size | PS.       | Velcro / Self-AD | For M7 Item NO. | Holes | pcs / set |
|-----------------|------|-----------|------------------|-----------------|-------|-----------|
| 0QB-9913V-08K10 | 3"   | Grit:#80  | Velcro           | QP-113          | Non   | 10        |
| 0QB-9913V-15K10 |      | Grit:#150 |                  |                 |       |           |
| 0QB-9913V-18K10 |      | Grit:#180 |                  |                 |       |           |
| 0QB-9913V-32K10 |      | Grit:#320 |                  |                 |       |           |
| 0QB-9913V-40K10 |      | Grit:#400 |                  |                 |       |           |
| 0QB-9915V-08K5  | 5"   | Grit:#80  |                  | QB-41           |       |           |
| 0QB-9915V-15K5  |      | Grit:#150 |                  |                 |       |           |
| 0QB-9915V-18K5  |      | Grit:#180 |                  |                 |       |           |
| 0QB-9915V-32K5  |      | Grit:#320 |                  |                 |       |           |
| 0QB-9915V-40K5  |      | Grit:#400 |                  |                 |       |           |
| 0QB-9916V-08K5  | 6"   | Grit:#80  | QB-42            |                 |       |           |
| 0QB-9916V-15K5  |      | Grit:#150 |                  |                 |       |           |
| 0QB-9916V-18K5  |      | Grit:#180 |                  |                 |       |           |
| 0QB-9916V-32K5  |      | Grit:#320 |                  |                 |       |           |
| 0QB-9916V-40K5  |      | Grit:#400 |                  |                 |       |           |
| 0QB-9905V-08K5  | 5"   | Grit:#80  | QB-43            | 6               | 5     |           |
| 0QB-9905V-15K5  |      | Grit:#150 |                  |                 |       |           |
| 0QB-9905V-18K5  |      | Grit:#180 |                  |                 |       |           |
| 0QB-9905V-32K5  |      | Grit:#320 |                  |                 |       |           |
| 0QB-9905V-40K5  |      | Grit:#400 |                  |                 |       |           |
| 0QB-9906V-08K5  | 6"   | Grit:#80  | QB-45            | 6               | 5     |           |
| 0QB-9906V-15K5  |      | Grit:#150 |                  |                 |       |           |
| 0QB-9906V-18K5  |      | Grit:#180 |                  |                 |       |           |
| 0QB-9906V-32K5  |      | Grit:#320 |                  |                 |       |           |
| 0QB-9906V-40K5  |      | Grit:#400 |                  |                 |       |           |



# AIR ADAPTOR QUICK COUPLINGS

AIR ADAPTOR QUICK COUPLINGS

## SY-2001M

360° Rotatable Adaptor  
Air Inlet 1/4"



## SY-2002M

Air Regulator & 360° Rotatable Adaptor  
Air Inlet 1/4"



## SY-2011M

360° Rotatable Adaptor  
Air Inlet 1/4"

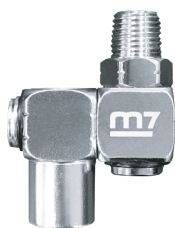

Blister+Card

### SY-M SY-F Air Adaptor / Quick Couplings

| Item No.           | Thread Type    | Thread Size        | Type   | Picture |  |
|--------------------|----------------|--------------------|--------|---------|--|
| SY-211M<br>SY-211F | Male<br>Female | 1/4" PT            | Europe |         |  |
| SY-221M<br>SY-321M | Male           | 1/4" PT<br>3/8" PT | Japan  |         |  |
| SY-221F<br>SY-321F | Female         | 1/4" PT<br>3/8" PT |        |         |  |
| SY-231M<br>SY-231F | Male<br>Female | 1/4" NPT           | U.S.A. |         |  |
| SY-251M<br>SY-351M | Male           | 1/4" PT<br>3/8" PT | France |         |  |
| SY-251F<br>SY-351F | Female         | 1/4" PT<br>3/8" PT |        |         |  |

| Item No.           | Thread Type    | Thread Size        | Type   | Picture |  |
|--------------------|----------------|--------------------|--------|---------|--|
| SY-210M<br>SY-210F | Male<br>Female | 1/4" PT            | Europe |         |  |
| SY-220M<br>SY-320M | Male           | 1/4" PT<br>3/8" PT | Japan  |         |  |
| SY-220F<br>SY-320F | Female         | 1/4" PT<br>3/8" PT |        |         |  |
| SY-230M<br>SY-230F | Male<br>Female | 1/4" NPT           | U.S.A. |         |  |



Blister+Card

## Composite Quick Coupling

| Item No.                         | Thread Type | Thread Size                   | Type            | Picture |
|----------------------------------|-------------|-------------------------------|-----------------|---------|
| SY-0213M<br>SY-0313M<br>SY-0413M | Male        | 1/4" PT<br>3/8" PT<br>1/2" PT | Europe          |         |
| SY-0223M<br>SY-0323M<br>SY-0423M | Male        | 1/4" PT<br>3/8" PT<br>1/2" PT | Japan           |         |
| SY-0233M<br>SY-0333M<br>SY-0433M | Male        | 1/4" PT<br>3/8" PT<br>1/2" PT | U.S.A<br>France |         |

| Item No.                         | Thread Type | Thread Size                   | Type            | Picture |
|----------------------------------|-------------|-------------------------------|-----------------|---------|
| SY-1213F<br>SY-1313F<br>SY-1413F | Female      | 1/4" PT<br>3/8" PT<br>1/2" PT | Europe          |         |
| SY-1223F<br>SY-1323F<br>SY-1423F | Female      | 1/4" PT<br>3/8" PT<br>1/2" PT | Japan           |         |
| SY-1233F<br>SY-1333F<br>SY-1433F | Female      | 1/4" PT<br>3/8" PT<br>1/2" PT | U.S.A<br>France |         |

| Item No.                         | Thread Type | Thread Size                    | Type            | Picture |
|----------------------------------|-------------|--------------------------------|-----------------|---------|
| SY-2213P<br>SY-2313P<br>SY-2413P | ---         | 5x8 mm<br>6.5x10 mm<br>8x12 mm | Europe          |         |
| SY-2223P<br>SY-2323P<br>SY-2423P | ---         | 5x8 mm<br>6.5x10 mm<br>8x12 mm | Japan           |         |
| SY-2233P<br>SY-2333P<br>SY-2433P | ---         | 5x8 mm<br>6.5x10 mm<br>8x12 mm | U.S.A<br>France |         |

| Item No.                                     | Thread Type | Thread Size                                       | Type            | Picture |
|--|-------------|---|-----------------|---------|
| SY-3113H<br>SY-3213H<br>SY-3313H<br>SY-3413H | ---         | 10SH 1/4"<br>20SH 5/16"<br>30SH 3/8"<br>40SH 1/2" | Europe          |         |
| SY-3123H<br>SY-3223H<br>SY-3323H<br>SY-3423H | ---         | 10SH 1/4"<br>20SH 5/16"<br>30SH 3/8"<br>40SH 1/2" | Japan           |         |
| SY-3133H<br>SY-3233H<br>SY-3333H<br>SY-3433H | ---         | 10SH 1/4"<br>20SH 5/16"<br>30SH 3/8"<br>40SH 1/2" | U.S.A<br>France |         |

# POWER BIT

## 1/4" POWER BIT (PHILLIPS HEAD)

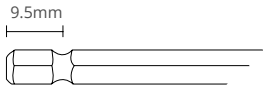

| "OVERALL LENGTH(mm)" | SIZE | ITEM NO.   | ØD(mm) |
|----------------------|------|------------|--------|
| 25                   | 2    | MD50125P2A | 6      |
|                      | 2    | MD50125P2R | 6      |
| 50                   | 0    | MD10150P0A | 3      |
|                      | 1    | MD10150P1A | 4.5    |
|                      | 2    | MD10150P2A | 6      |
|                      | 3    | MD10150P3A | 6      |
| 70                   | 1    | MD10170P1A | 4.5    |
|                      | 2    | MD10170P2A | 6      |
|                      | 3    | MD10170P3A | 6      |

## 1/4" POWER BIT (POZIDRIV HEAD)

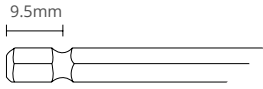

| "OVERALL LENGTH(mm)" | SIZE | ITEM NO.   | ØD(mm) |
|----------------------|------|------------|--------|
| 25                   | 2    | MD50125Z2A | 6      |
| 50                   | 0    | MD10150Z0A | 3      |
|                      | 1    | MD10150Z1A | 4.5    |
|                      | 2    | MD10150Z2A | 6      |
| 70                   | 3    | MD10150Z3A | 6      |
|                      | 1    | MD10170Z1A | 4.5    |
|                      | 2    | MD10170Z2A | 6      |
|                      | 3    | MD10170Z3A | 6      |

## 1/4" POWER BIT (STAR TAMPER HEAD)

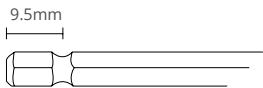

| "OVERALL LENGTH(mm)" | SIZE | ITEM NO.     | ØD(mm) |
|----------------------|------|--------------|--------|
| 90                   | 10   | MD10190TT10A | 4      |
|                      | 15   | MD10190TT15A | 4      |
|                      | 20   | MD10190TT20A | 4.8    |
|                      | 25   | MD10190TT25A | 4.8    |
|                      | 30   | MD10190TT30A | 6      |

| "OVERALL LENGTH(mm)" | SIZE | ITEM NO.     | ØD(mm) |
|----------------------|------|--------------|--------|
| 50                   | 6    | MD10150TT06A | 3.2    |
|                      | 7    | MD10150TT07A | 3.2    |
|                      | 8    | MD10150TT08A | 3.2    |
|                      | 9    | MD10150TT09A | 3.2    |
|                      | 10   | MD10150TT10A | 4      |
|                      | 15   | MD10150TT15A | 4      |
|                      | 20   | MD10150TT20A | 4.8    |
|                      | 25   | MD10150TT25A | 4.8    |
|                      | 27   | MD10150TT27A | 6      |
|                      | 30   | MD10150TT30A | 6      |
| 70                   | 40   | MD10150TT40A | 6.3    |
|                      | 6    | MD10170TT06A | 3.2    |
|                      | 7    | MD10170TT07A | 3.2    |
|                      | 8    | MD10170TT08A | 3.2    |
|                      | 9    | MD10170TT09A | 3.2    |
|                      | 10   | MD10170TT10A | 4      |
|                      | 15   | MD10170TT15A | 4      |
|                      | 20   | MD10170TT20A | 4.8    |
|                      | 25   | MD10170TT25A | 4.8    |
|                      | 27   | MD10170TT27A | 6      |
| 70                   | 30   | MD10170TT30A | 6      |
|                      | 40   | MD10170TT40F | 6.3    |
|                      | 45   | MD10170TT45E | 8      |
|                      | 50   | MD05170TT50E | 9.1    |

# 1/4" POWER BIT

(DOUBLE PHILLIPS HEAD)

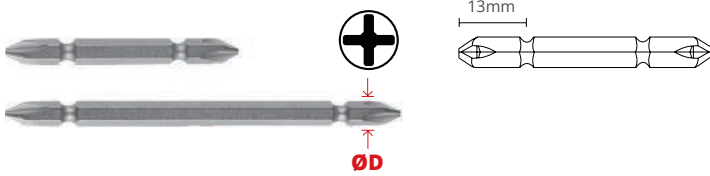

| "OVERALL LENGTH(mm)" | SIZE | ITEM NO.      |
|----------------------|------|---------------|
| 65                   | 1    | MD10165P1P1A  |
|                      | 2    | MD10165P2P2A  |
|                      | 3    | MD10165P3P3A  |
| 110                  | 1    | MD101110P1P1A |
|                      | 2    | MD101110P2P2A |
|                      | 3    | MD101110P3P3A |

# 1/4" POWER BIT

(HEX HEAD)

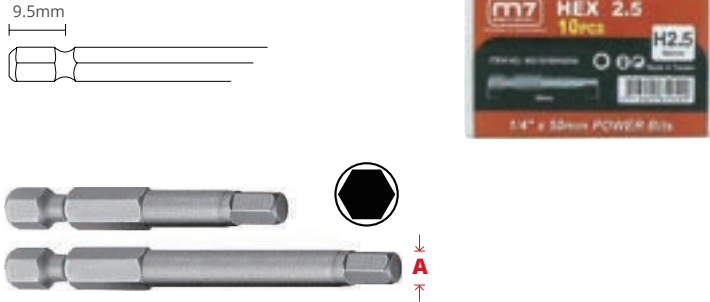

| "OVERALL LENGTH(mm)" | A(mm) | ITEM NO.      |
|----------------------|-------|---------------|
| 150                  | 2.5   | MD101150H025A |
|                      | 3     | MD101150H030A |
|                      | 4     | MD101150H040A |
|                      | 5     | MD101150H050A |
|                      | 6     | MD101150H060A |

| "OVERALL LENGTH(mm)" | A(mm) | ITEM NO.     |
|----------------------|-------|--------------|
| 50                   | 1.5   | MD10150H015A |
|                      | 2     | MD10150H020A |
|                      | 2.5   | MD10150H025A |
|                      | 3     | MD10150H030A |
|                      | 4     | MD10150H040A |
|                      | 5     | MD10150H050A |
|                      | 6     | MD10150H060F |
|                      | 7     | MD10150H070E |
|                      | 8     | MD10150H080E |
|                      | 10    | MD10150H100E |
| 70                   | 1.5   | MD10170H015A |
|                      | 2     | MD10170H020A |
|                      | 2.5   | MD10170H025A |
|                      | 3     | MD10170H030A |
|                      | 4     | MD10170H040A |
|                      | 5     | MD10170H050A |
|                      | 6     | MD10170H060F |
|                      | 7     | MD10170H070E |
|                      | 8     | MD10170H080E |
|                      | 10    | MD05170H100E |

# 1/4" POWER BIT

(STAR HEAD)

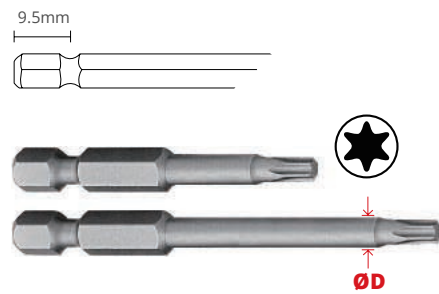

| "OVERALL LENGTH(mm)" | SIZE | ITEM NO.    | ØD(mm) |
|----------------------|------|-------------|--------|
| 25                   | 20   | MD10125T20A | 4.8    |

| "OVERALL LENGTH(mm)" | SIZE        | ITEM NO.    | ØD(mm) |
|----------------------|-------------|-------------|--------|
| 50                   | 6           | MD10150T06A | 3.2    |
|                      | 7           | MD10150T07A | 3.2    |
|                      | 8           | MD10150T08A | 3.2    |
|                      | 9           | MD10150T09A | 3.2    |
|                      | 10          | MD10150T10A | 4      |
|                      | 15          | MD10150T15A | 4      |
|                      | 20          | MD10150T20A | 4.8    |
|                      | 25          | MD10150T25A | 4.8    |
|                      | 27          | MD10150T27A | 6      |
|                      | 30          | MD10150T30A | 6      |
|                      | 40          | MD10150T40F | 7      |
|                      | 45          | MD10150T45E | 8      |
|                      | 50          | MD05150T50E | 9.1    |
| 70                   | 6           | MD10170T06A | 3.2    |
|                      | 7           | MD10170T07A | 3.2    |
|                      | 8           | MD10170T08A | 3.2    |
|                      | 9           | MD10170T09A | 3.2    |
|                      | 10          | MD10170T10A | 4      |
|                      | 15          | MD10170T15A | 4      |
|                      | 20          | MD10170T20A | 4.8    |
|                      | 25          | MD10170T25A | 4.8    |
|                      | 27          | MD10170T27A | 6      |
|                      | 30          | MD10170T30A | 6      |
|                      | 40          | MD10170T40F | 7      |
|                      | 45          | MD10170T45E | 8      |
|                      | 50          | MD10170T50E | 9.1    |
| 45                   | MD08170T45E | 8           |        |
| 50                   | MD05170T50E | 9.1         |        |

# MERCHANDISE

## ZC-201R T-SHIRT



|      |     |     |    |    |     |
|------|-----|-----|----|----|-----|
| SIZE | S   | M   | L  | XL | 2XL |
|      | 3XL | 4XL | 3L | 4L | 5L  |

## ZC-201B T-SHIRT



|      |     |     |    |    |     |
|------|-----|-----|----|----|-----|
| SIZE | S   | M   | L  | XL | 2XL |
|      | 3XL | 4XL | 3L | 4L | 5L  |

## ZC-501 T-SHIRT



|      |     |     |    |    |     |
|------|-----|-----|----|----|-----|
| SIZE | S   | M   | L  | XL | 2XL |
|      | 3XL | 4XL | 3L | 4L | 5L  |

## ZB-812 ANTI-VIBRATION GLOVE

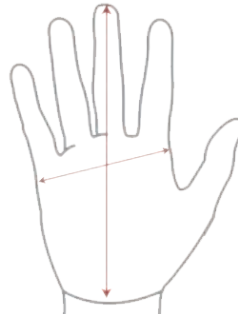

- Palm length :
- Distance between middle finger to bottom of the palm
- Palm width :
- Distance between left side and right side of the palm
- CE EN388 2121X

## ZB-814 HALF FINGER BLADE CUT RESISTANCE GLOVE



| Item Description | length(cm) | wide(cm) |
|------------------|------------|----------|
| M                | 21.3       | 10.5     |
| L                | 22         | 11       |
| XL               | 22.7       | 11.5     |
| XXL              | 23.4       | 12       |

## ZC-202-1 BASEBALL CAP



## ZC-9156 LED PEN LIGHT

- LED x 4pcs
- No. 4 battery x 3pcs included



## ZB-307 PEN



## ZB-306 PEN(STYLUS)

- Pen with touch function



## ZC-111

TOOL BAG

• 37 x 24 x 23cm



## ZC-112

TOOL BAG(RUBBER BASE)

• 40 x 22 x 30cm



## ZC-108

BAG



## ZF-02

WING PROTECTOR COVER



## ZF-01

WING PROTECTOR COVER



## ZE-03

KNEELING PAD



## ZC-301

STICKERS

• 100 x 112mm



## ZB-211

MUG



## ZM-101

27" AUTOMATIC UMBRELLA



## ZC-302

STICKERS

• 200 x 110mm



## ZC-303

STICKERS

• 199 x 106mm



## ZC-304

STICKERS

• 288 x 156mm



## ZH-104

MINI USB LED FLASHLIGHT



## YA-0303

QUICK ASSEMBLY TENT

• Size : 3.3m  
• Area : 9m<sup>2</sup>  
• Weight : 22.5kg  
• Top high : 3.5m



## SE-1001

LED SLIM LIGHT



## User's Manual of Air Impact Wrench

### Working environment:

- Using these tools in any potentially explosive environment is strictly prohibited.
- It is always recommended that these types of tools must be operated when standing on a solid or firm location.
- Always use these tools in a well ventilated area.
- Slipping, stumbling and falling are the major causes of potential serious injury, therefore, a clean and clutter free surface in the working area before operating the tools is strongly recommended.

### Air supply and connection requirements:

- The maximum recommended air pressure during operation must not exceed 90 psi (6.3bar). Higher air pressure may create unsafe operating conditions for the tool and the user.
- The compressed air should be cooled and have a water filter installed at the outlet end of the compressor. Even with a water filter installed, some water may still condense in the piping or hose and will enter the tool mechanism causing premature damage to the tool. Therefore, it is recommended to install an air filter-lubricator device somewhere between the tool and the compressor.
- Always use an air compressor of the proper capacity to operate each tool.
- Clean the hose with a blast of compressed air before connecting the hose to the air tool. This will prevent both moisture and dust inside the hose from entering the tool and causing possible rust or malfunction.

## Air Tool Repair Kits



M7 provides specialized repairing tools for your after market need

## Ideal system connection

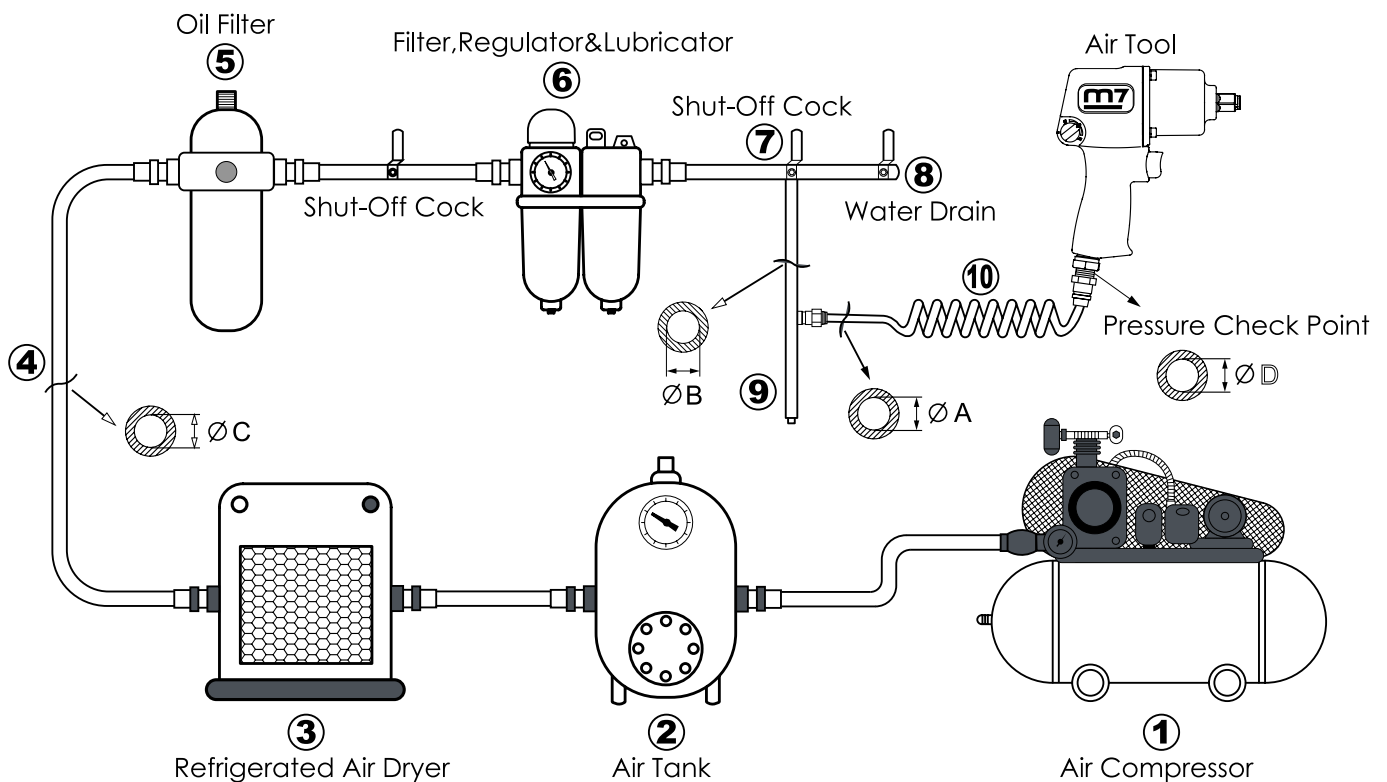

## Piping diameters and length requirement:

- The diameter  $\Phi A$  required for the inlet pipe (10) is recommended on the specification table.
- The diameter  $\Phi B$  required for the branch pipe (from 7 to 9) should be 2 times as large as  $\Phi A$ .  $\Phi B = 2 \times \Phi A$
- The diameter  $\Phi C$  required for the primary air supply (from 1 to 8) should be 3 times as large as  $\Phi A$ .  $\Phi C = 3 \times \Phi A$
- The length for the inlet pipe (10) should be less than 15 feet (4.5m).

## Impact Wrench

| Problem (phenomenon)   | Possible Cause  | Recommended solution   |
|--|---|--|
| <ol style="list-style-type: none"> <li>1. The tool runs automatically or tool will not shut off.</li> <li>2. Torque decreases slightly.</li> <li>3. Sound of air leaking.</li> </ol> | <ol style="list-style-type: none"> <li>1. Dust jam.</li> </ol>  | <ol style="list-style-type: none"> <li>1. Clean and remove the dust from the air inlet.</li> <li>2. Clean the throttle valve.</li> <li>3. Apply a few drops of recommended pneumatic oil into the air inlet.</li> <li>4. Pull the trigger and run for several seconds to get rid of the dust.</li> </ol> |
| <ol style="list-style-type: none"> <li>1. Severe torque loss, but will still run at full free speed,</li> <li>2. Tool will not run.</li> </ol>                                       | <ol style="list-style-type: none"> <li>1. The rotor blades may be damaged,</li> <li>2. The screws may be loose.</li> <li>3. The reverse button (knob) may be out off position.</li> <li>4. Some component(s) in motor housing or hammer housing may be worn off.</li> </ol> | <ol style="list-style-type: none"> <li>1. Check and replace new ones, if necessary.</li> <li>2. Tighten all loose screws.</li> <li>3. Adjust the button.</li> <li>4. Check and replace them, if necessary.</li> </ol>  |
| <ol style="list-style-type: none"> <li>1. Air leaks from hammer housing or rear cover.</li> </ol>  | <ol style="list-style-type: none"> <li>1. The screws may be loose.</li> <li>2. The gasket seal may be broken.</li> </ol>  | <ol style="list-style-type: none"> <li>1. Tighten all loose screws.</li> <li>2. Replace it.</li> </ol>   |

**Note:** The consumable parts are the rotor blades, anvil and hammer.

## Ratchet Wrench

| Problem (phenomenon)   | Possible Cause  | Recommended solution   |
|--|---|--|
| <ol style="list-style-type: none"> <li>1. The tool runs automatically or tool will not shut off.</li> <li>2. Torque decreases slightly.</li> <li>3. Sound of air leaking.</li> </ol> | <ol style="list-style-type: none"> <li>1. Dust jam.</li> </ol>  | <ol style="list-style-type: none"> <li>1. Clean and remove the dust from the air inlet.</li> <li>2. Clean the throttle valve.</li> <li>3. Apply a few drops of recommended pneumatic oil into the air inlet.</li> <li>4. Pull the trigger and run for several seconds to get rid of the dust.</li> </ol> |
| <ol style="list-style-type: none"> <li>1. Severe torque loss, but will still run at full free speed,</li> <li>2. Tool will not run.</li> </ol>                                       | <ol style="list-style-type: none"> <li>1. The rotor blades may be damaged,</li> <li>2. The screws may be loose.</li> <li>3. The reverse button (knob) may be out off position.</li> <li>4. Some component(s) in motor housing or hammer housing may be worn off.</li> </ol> | <ol style="list-style-type: none"> <li>1. Check and replace new ones, if necessary.</li> <li>2. Tighten all loose screws.</li> <li>3. Adjust the button.</li> <li>4. Check and replace them, if necessary.</li> </ol>  |

**Note:** The consumable parts are the rotor blades, gears and ratchet anvil.

## Die Grinder

| Problem (phenomenon)   | Possible Cause  | Recommended solution  |
|--|---|---|
| <ol style="list-style-type: none"> <li>1. The tool runs automatically or tool will not shut off.</li> <li>2. Torque decreases slightly.</li> <li>3. Sound of air leaking.</li> </ol> | <ol style="list-style-type: none"> <li>1. Dust jam.</li> <li>2. Trigger may be damaged!</li> </ol>  | <ol style="list-style-type: none"> <li>1. Clean to remove the dust from the air inlet.</li> <li>2. Clean the throttle valve.</li> <li>3. Apply a few drops of recommended pneumatic oil into the air inlet.</li> <li>4. Push trigger and run for several seconds to get rid of the dust.</li> <li>5. Inspect the trigger, correct or replace the related component when necessary.</li> </ol> |
| <ol style="list-style-type: none"> <li>1. Severe torque loss, but will still run at full free speed,</li> <li>2. Tool will not run.</li> </ol>                                       | <ol style="list-style-type: none"> <li>1. The rotor blades may be damaged,</li> <li>2. The screws may be loose.</li> <li>3. The Air Regulator may not be in correct position.</li> <li>4. The Collet Nut may be loose.</li> </ol> | <ol style="list-style-type: none"> <li>1. Check and replace with new ones, if necessary.</li> <li>2. Tighten all loose screws.</li> <li>3. Check and correct.</li> <li>4. Check and tighten.</li> </ol>   |

**Note:** The consumable parts are the rotor blades, bearings and collet.



## Air Cutting Off Tool

| Problem (phenomenon)   | Possible Cause   | Recommended solution   |
|--|--|--|
| <ol style="list-style-type: none"> <li>1. The tool runs automatically or tool will not shut off.</li> <li>2. Torque decreases slightly.</li> <li>3. Sound of air leaking.</li> </ol> | <ol style="list-style-type: none"> <li>1. Dust jam.</li> <li>2. Trigger may be damaged!</li> </ol>   | <ol style="list-style-type: none"> <li>1. Clean and remove the dust from the air inlet.</li> <li>2. Clean the throttle valve.</li> <li>3. Apply a few drops of recommended pneumatic oil into the air inlet.</li> <li>4. Push trigger and run for several seconds to get rid of the dust.</li> <li>5. Inspect the trigger, correct or replace the related component when necessary.</li> </ol> |
| <ol style="list-style-type: none"> <li>1. Severe torque loss, but will still run at full free speed.</li> <li>2. Tool will not run.</li> </ol>                                       | <ol style="list-style-type: none"> <li>1. The rotor blades may be damaged.</li> <li>2. The screws may be loose.</li> <li>3. The Air Regulator may not be in correct position.</li> </ol> | <ol style="list-style-type: none"> <li>1. Check and replace with new ones, if necessary.</li> <li>2. Tighten all loose screws.</li> <li>3. Check and correct.</li> </ol>   |

Note: The consumable parts are the rotor blades and bearings.

## Air angle Grinder

| Problem (phenomenon)   | Possible Cause  | Recommended solution   |
|--|---|--|
| <ol style="list-style-type: none"> <li>1. The tool runs automatically or tool will not shut off.</li> <li>2. Torque decreases slightly.</li> <li>3. Sound of air leaking.</li> </ol> | <ol style="list-style-type: none"> <li>1. Dust jam.</li> <li>2. Trigger may be damaged!</li> </ol>  | <ol style="list-style-type: none"> <li>1. Clean and remove the dust from the air inlet.</li> <li>2. Clean the throttle valve.</li> <li>3. Apply a few drops of recommended pneumatic oil into the air inlet.</li> <li>4. Push trigger and run for several seconds to get rid of the dust.</li> <li>5. Inspect the trigger, correct or replace the related component when necessary.</li> </ol> |
| <ol style="list-style-type: none"> <li>1. Severe torque loss, but will still run at full free speed.</li> <li>2. Tool will not run.</li> </ol>                                       | <ol style="list-style-type: none"> <li>1. The rotor blades may be damaged.</li> <li>2. The screws may be loose.</li> <li>3. The bevel gears may not have enough grease.</li> <li>4. The bevel gears may be worn off.</li> </ol> | <ol style="list-style-type: none"> <li>1. Check and replace new ones, if necessary.</li> <li>2. Tighten all loose screws.</li> <li>3. Apply some multiple-purpose grease.</li> <li>4. Replace them.</li> </ol>   |

Note: The consumable parts are the rotor blades and bearings.

## Belt Sander

| Problem (phenomenon)   | Possible Cause  | Recommended solution   |
|--|---|--|
| <ol style="list-style-type: none"> <li>1. The tool runs automatically or tool will not shut off.</li> <li>2. Torque decreases slightly.</li> <li>3. Sound of air leaking.</li> </ol> | <ol style="list-style-type: none"> <li>1. Dust jam.</li> </ol>  | <ol style="list-style-type: none"> <li>1. Clean and remove the dust from the air inlet.</li> <li>2. Clean the throttle valve.</li> <li>3. Apply a few drops of recommended pneumatic oil into the air inlet.</li> <li>4. Pull the trigger and run for several seconds to get rid of the dust.</li> </ol> |
| <ol style="list-style-type: none"> <li>1. Severe torque loss, but will still run at full free speed.</li> <li>2. Tool will not run.</li> </ol>                                       | <ol style="list-style-type: none"> <li>1. The rotor blades may be damaged.</li> <li>2. The screws may be loose.</li> <li>3. The belt may not be seated correctly.</li> <li>4. The bearings may be damaged.</li> </ol> | <ol style="list-style-type: none"> <li>1. Check and replace with new ones, if necessary.</li> <li>2. Tighten all loose screws.</li> <li>3. Adjust it.</li> <li>4. Replace them.</li> </ol>   |

Note: The consumable parts are the rotor blades and bearings.

## Air Sander

| Problem (phenomenon)   | Possible Cause   | Recommended solution   |
|--|--|--|
| <ol style="list-style-type: none"> <li>1. The tool runs automatically or tool will not shut off.</li> <li>2. Torque decreases slightly.</li> <li>3. Sound of air leaking.</li> </ol> | <ol style="list-style-type: none"> <li>1. Dust jam.</li> <li>2. Trigger may be damaged!</li> </ol>   | <ol style="list-style-type: none"> <li>1. Clean and remove the dust from the air inlet.</li> <li>2. Clean the throttle valve.</li> <li>3. Apply a few drops of recommended pneumatic oil into the air inlet.</li> <li>4. Pull the trigger and run for several seconds to get rid of the dust.</li> </ol> |
| <ol style="list-style-type: none"> <li>1. Severe torque loss, but will still run at full free speed.</li> <li>2. Tool will not run.</li> </ol>                                       | <ol style="list-style-type: none"> <li>1. The rotor blades may be damaged,</li> <li>2. The pad may not be correct.</li> <li>3. The screws may be loose.</li> </ol> | <ol style="list-style-type: none"> <li>1. Check and replace with new ones, if necessary.</li> <li>2. Check and replace with the correct one.</li> <li>3. Tighten all loose screws.</li> </ol>  |

**Note:** The consumable parts are the rotor blades and bearings.

## Air Shear

| Problem (phenomenon)   | Possible Cause  | Recommended solution   |
|--|---|--|
| <ol style="list-style-type: none"> <li>1. The tool runs automatically or tool will not shut off.</li> <li>2. Torque decreases slightly.</li> <li>3. Sound of air leaking.</li> </ol> | <ol style="list-style-type: none"> <li>1. Dust jam.</li> </ol>  | <ol style="list-style-type: none"> <li>1. Clean and remove the dust from the air inlet.</li> <li>2. Clean the throttle valve.</li> <li>3. Apply a few drops of recommended pneumatic oil into the air inlet.</li> <li>4. Pull the trigger and run for several seconds to get rid of the dust.</li> </ol> |
| <ol style="list-style-type: none"> <li>1. Severe torque loss, but will still run at full free speed,</li> <li>2. Tool will not run.</li> </ol>                                       | <ol style="list-style-type: none"> <li>1. The rotor blades may be damaged,</li> <li>2. The cutting blades may not be sharp enough.</li> <li>3. The cutting blades may not be in the correct position.</li> <li>4. The lock screws for cutting blades may be loose.</li> </ol> | <ol style="list-style-type: none"> <li>1. Check and replace with new ones, if necessary.</li> <li>2. Check and replace with new ones, if necessary.</li> <li>3. Check and adjust them.</li> <li>4. Check and tighten.</li> </ol>   |

**Note:** The consumable parts are the rotor blades and bearings.

## Air Saw

| Problem (phenomenon)   | Possible Cause   | Recommended solution   |
|--|--|--|
| <ol style="list-style-type: none"> <li>1. The tool runs automatically or tool will not shut off.</li> <li>2. Torque decreases slightly.</li> <li>3. Sound of air leaking.</li> </ol> | <ol style="list-style-type: none"> <li>1. Dust jam.</li> <li>2. Trigger may be damaged!</li> </ol> | <ol style="list-style-type: none"> <li>1. Clean and remove the dust from the air inlet.</li> <li>2. Clean the throttle valve.</li> <li>3. Apply a few drops of recommended pneumatic oil into the air inlet.</li> <li>4. Pull the trigger and run for several seconds to get rid of the dust.</li> </ol> |
| <ol style="list-style-type: none"> <li>1. Severe torque loss, but will still run at full free speed.</li> <li>2. Tool will not run.</li> </ol>                                       | <ol style="list-style-type: none"> <li>1. The rotor blades may be damaged.</li> </ol>              | <ol style="list-style-type: none"> <li>1. Check and replace with new ones, if necessary.</li> </ol>  |
| <ol style="list-style-type: none"> <li>1. Severe decrease in reciprocating speed.</li> </ol>   | <ol style="list-style-type: none"> <li>1. The drive motor may be dirty.</li> </ol>                 | <ol style="list-style-type: none"> <li>1. Cleaning required.</li> </ol>  |

**Note:** The consumable parts are the rotor blades and bearings.

| Problem (phenomenon)  | Possible Cause  | Recommended solution   |
|---|---|--|
| <p><b>Air Drill</b></p> <ol style="list-style-type: none"> <li>1. The tool runs automatically or tool will not shut off.</li> <li>2. Torque decreases slightly.</li> <li>3. Sound of air leaking.</li> </ol>        | <ol style="list-style-type: none"> <li>1. Dust jam.</li> </ol>  | <ol style="list-style-type: none"> <li>1. Clean and remove the dust from the air inlet.</li> <li>2. Clean the throttle valve.</li> <li>3. Apply a few drops of recommended pneumatic oil into the air inlet.</li> <li>4. Pull the trigger and run for several seconds to get rid of the dust.</li> </ol> |
| <ol style="list-style-type: none"> <li>1. Severe torque loss, but will still run at full free speed.</li> <li>2. Tool will not run.</li> </ol>  | <ol style="list-style-type: none"> <li>1. The rotor blades may be damaged,</li> <li>2. The keyless chuck may be damaged.</li> </ol>   | <ol style="list-style-type: none"> <li>1. Check both possibilities and replace with new ones, if necessary.</li> </ol>   |
| <p><b>Note: The consumable parts are the rotor blades and bearings.</b></p>   |   |  |
| <p><b>Air Screwdriver</b></p> <ol style="list-style-type: none"> <li>1. The tool runs automatically or tool will not shut off.</li> <li>2. Torque decreases slightly.</li> <li>3. Sound of air leaking.</li> </ol>  | <ol style="list-style-type: none"> <li>1. Dust jam.</li> </ol>  | <ol style="list-style-type: none"> <li>1. Clean and remove the dust from the air inlet.</li> <li>2. Clean the throttle valve.</li> <li>3. Apply a few drops of recommended pneumatic oil into the air inlet.</li> <li>4. Pull the trigger and run for several seconds to get rid of the dust.</li> </ol> |
| <ol style="list-style-type: none"> <li>1. Severe torque loss, but will still run at full free speed,</li> <li>2. Tool will not run.</li> </ol>  | <ol style="list-style-type: none"> <li>1. The rotor blades may be damaged,</li> <li>2. The screws may be loose.</li> <li>3. The Reverse Knob may be damaged or not in the right position.</li> <li>4. The impact mechanism may be damaged.</li> </ol> | <ol style="list-style-type: none"> <li>1. Check both possibilities and replace with new ones, if necessary.</li> <li>2. Tighten all the loose screws.</li> <li>3. Check and adjust, or replace with a new one if necessary.</li> <li>4. Check and replace with a new set, if necessary.</li> </ol>       |
| <p><b>Note: The consumable parts are the rotor blades and bearings.</b></p>   |   |  |
| <p><b>Air Hammer</b></p> <ol style="list-style-type: none"> <li>1. The tool runs automatically or tool will not shut off.</li> <li>2. Torque decreases slightly.</li> <li>3. Sound of air leaking.</li> </ol>       | <ol style="list-style-type: none"> <li>1. Dust jam.</li> </ol>  | <ol style="list-style-type: none"> <li>1. Clean and remove the dust from the air inlet.</li> <li>2. Clean the throttle valve.</li> <li>3. Apply a few drops of recommended pneumatic oil into the air inlet.</li> <li>4. Pull the trigger and run for several seconds to get rid of the dust.</li> </ol> |
| <ol style="list-style-type: none"> <li>1. The tool doesn't work</li> </ol>  | <ol style="list-style-type: none"> <li>1. The piston may be jammed or damaged.</li> <li>2. The size of chisel may not be correct.</li> </ol>  | <ol style="list-style-type: none"> <li>1. Check and replace the related component when necessary.</li> <li>2. Check and replace with the correct one.</li> </ol>   |
| <p><b>Note: The consumable parts are the throttle valve and piston.</b></p>   |   |  |
| <p><b>Hydraulic Riveter</b></p> <ol style="list-style-type: none"> <li>1. The tool runs automatically or tool will not shut off.</li> <li>2. Power decreases slightly.</li> <li>3. Sound of air leaking.</li> </ol> | <ol style="list-style-type: none"> <li>1. Dust jam.</li> </ol>  | <ol style="list-style-type: none"> <li>1. Clean and remove the dust from the air inlet.</li> <li>2. Clean the throttle valve.</li> <li>3. Apply a few drops of recommended pneumatic oil into the air inlet.</li> <li>4. Pull the trigger and run for several seconds to get rid of the dust.</li> </ol> |
| <ol style="list-style-type: none"> <li>1. The tool doesn't work</li> </ol>  | <ol style="list-style-type: none"> <li>1. The size of rivet may not be suitable.</li> <li>2. The size of rivet nose may not be correct.</li> </ol>  | <ol style="list-style-type: none"> <li>1. Check and use the correct ones.</li> <li>2. Check and replace with the correct one!</li> </ol>   |
| <p><b>Note: The consumable parts are the rivet nose, jaw housing, front housing and spring.</b></p>   |   |  |

**Note:**

For more details about the above recommended solutions, please refer to the use'r Manual attached along with each product.

# ALPHABETIC INDEX

## A

|             |     |
|-------------|-----|
| AD-101      | 103 |
| AD-201      | 103 |
| AD-22/23/24 | 96  |
| AD-303-41   | 102 |
| AD-305-41   | 102 |
| AD-306      | 103 |
| AD-306DB    | 103 |
| AD-307      | 102 |
| AD-308      | 102 |
| AD-309      | 102 |
| AD-35       | 101 |
| AD-351      | 102 |
| AD-3511P    | 101 |
| AD-3511T    | 101 |
| AD-36       | 101 |
| AD-361      | 102 |
| AD-431      | 103 |

## D

|               |     |
|---------------|-----|
| DB-1825       | 139 |
| DB-1850P      | 139 |
| DC-18A        | 139 |
| DCS-101       | 135 |
| DCS-101A      | 135 |
| DD-101        | 134 |
| DD-101A       | 134 |
| DFL-101       | 137 |
| DG-501        | 136 |
| DG-501A       | 136 |
| DG-585        | 136 |
| DG-585502A    | 136 |
| DGG-102       | 131 |
| DH-101        | 134 |
| DH-101A       | 134 |
| DHG-101       | 131 |
| DJS-101       | 135 |
| DJS-101A      | 135 |
| DOM-101       | 130 |
| DOS-501       | 136 |
| DOS-501A      | 136 |
| DPW-101       | 131 |
| DR-102        | 130 |
| DRH-101       | 130 |
| DRS-101       | 135 |
| DRS-101A      | 135 |
| DRS-102       | 135 |
| DRS-102A      | 135 |
| DS-10202      | 137 |
| DS-201        | 137 |
| DS-201A       | 137 |
| DW-1840       | 138 |
| DW-18502A KIT | 138 |
| DW-401        | 133 |
| DW-401A       | 133 |
| DW-402        | 133 |
| DW-402A       | 133 |
| DW-404        | 132 |
| DW-406        | 132 |
| DW-601        | 133 |
| DW-601A       | 133 |

## G

|            |    |
|------------|----|
| GMH-203006 | 80 |
| GMH-207015 | 80 |
| GMH-212025 | 80 |
| GMI-206006 | 80 |
| GMI-215015 | 80 |
| GMI-225025 | 80 |
| GMS-203006 | 80 |
| GMS-207015 | 80 |
| GMS-212025 | 80 |
| GTA-201030 | 79 |
| GTA-306135 | 79 |
| GTA-406135 | 79 |
| GTA-410200 | 79 |
| GTA-417340 | 79 |
| GTA-606060 | 79 |
| GTA-610100 | 79 |
| GTA-810100 | 79 |
| GTA-930    | 81 |
| GTA-940    | 81 |
| GTA-941    | 81 |
| GTB-201030 | 79 |
| GTB-306135 | 79 |
| GTB-410200 | 80 |
| GTB-417340 | 80 |
| GTF-203030 | 79 |
| GTF-313135 | 79 |
| GTF-420200 | 79 |
| GTF-434340 | 79 |
| GTW-201030 | 81 |
| GTW-306135 | 81 |
| GTW-406135 | 81 |
| GTW-410200 | 81 |
| GTW-417340 | 81 |
| GTW-606060 | 81 |
| GTW-610100 | 81 |
| GTW-810100 | 81 |
| GTW-930    | 81 |
| GTW-940    | 81 |
| GTW-941    | 81 |

## J

|              |    |
|--------------|----|
| JC-0415[SET] | 64 |
| JC-0424[SET] | 64 |
| JC-202       | 64 |
| JC-405       | 64 |
| JC-410       | 64 |
| JC-412       | 64 |
| JC-424       | 64 |
| JC-435       | 64 |
| JC-491       | 64 |
| JC-602       | 64 |
| JC-640       | 64 |
| JC-641       | 64 |
| JC-680       | 64 |

## M

|             |     |
|-------------|-----|
| MA211M      | 86  |
| MA211S      | 86  |
| MA231M      | 87  |
| MA231S      | 87  |
| MA311M      | 87  |
| MA311S      | 87  |
| MA331M      | 88  |
| MA331S      | 88  |
| MA401M      | 88  |
| MA401S      | 88  |
| MA4030      | 84  |
| MA4031M85   | 84  |
| MA411M      | 88  |
| MA411S      | 88  |
| MA-412M1719 | 108 |
| MA-412M2122 | 108 |
| MA-412S2426 | 108 |
| MA42006M    | 84  |
| MA42006S    | 84  |
| MA42011S    | 85  |
| MA42015M    | 84  |
| MA42026     | 84  |
| MA431M      | 90  |
| MA431S      | 90  |
| MA4550M50   | 82  |
| MA611M      | 91  |
| MA611S      | 91  |
| MA631M      | 92  |
| MA631S      | 92  |
| MA641M      | 97  |
| MA641S      | 97  |
| MA643M      | 97  |
| MA8050      | 84  |
| MA811M      | 93  |
| MA811S      | 93  |
| MA831M      | 94  |
| MA831S      | 94  |
| MA841M      | 97  |
| MA841S      | 97  |
| MA843M      | 97  |
| MA911M      | 95  |
| MA911S      | 95  |
| MA931M      | 96  |
| MA931S      | 96  |
| MB34012S    | 82  |
| MB34013M    | 82  |
| MB35012S    | 82  |
| MB35013M    | 82  |
| MB371S      | 96  |
| MB42011M    | 85  |
| MB43015M    | 82  |
| MB44008M    | 82  |
| MB44008S    | 82  |
| MB44013S    | 82  |
| MB44014M    | 82  |
| MB45010M    | 82  |
| MB45013S    | 82  |
| MB45014M    | 83  |
| MB46008R    | 83  |
| MB46010R    | 83  |
| MB47010M    | 85  |
| MB61008M    | 85  |
| MB61016M    | 85  |
| MB63008M    | 85  |
| MB63008S    | 85  |

## M

|                   |     |
|-------------------|-----|
| MB64008M          | 83  |
| MB64008M1         | 83  |
| MB64008S          | 83  |
| MB64008SP         | 83  |
| MB65008M          | 83  |
| MB65008M1         | 83  |
| MB65008S          | 83  |
| MB65008S1         | 83  |
| MB66006M          | 83  |
| MB66006S          | 83  |
| MB67006M          | 85  |
| MB81009M          | 85  |
| MB85008M          | 85  |
| MD10150H Series   | 115 |
| MD10150P Series   | 114 |
| MD10150T Series   | 115 |
| MD10150TT Series  | 114 |
| MD10165P1P Series | 115 |
| MD50125P2A        | 114 |
| MD50125P2R        | 114 |
| MD50125Z2A        | 114 |
| ME011N            | 84  |
| ME221             | 98  |
| ME2711            | 98  |
| ME271M08-7        | 98  |
| ME271M10-7        | 98  |
| ME321             | 98  |
| ME3711            | 98  |
| ME371M            | 99  |
| ME371S            | 99  |
| ME371T            | 99  |
| ME382             | 98  |
| ME384             | 98  |
| ME4050            | 100 |
| ME421             | 99  |
| ME422             | 100 |
| ME4711            | 98  |
| ME471M            | 99  |
| ME471S            | 99  |
| ME471T            | 99  |
| ME472S            | 98  |
| ME483             | 98  |
| ME486             | 98  |
| ME486H            | 98  |
| ME621             | 99  |
| ME6711            | 98  |
| ME6711H           | 98  |
| ME671M            | 100 |
| ME671S            | 100 |
| ME684             | 98  |
| ME684H            | 98  |
| ME688             | 98  |
| ME688H            | 98  |
| ME821             | 99  |
| ME8711            | 98  |
| ME8711H           | 98  |
| ME871M            | 100 |
| ME886             | 98  |
| ME886H            | 98  |
| ME889             | 98  |
| ME904             | 100 |
| ME906             | 100 |
| ME908             | 100 |
| ME9711            | 98  |

# ALPHABETIC INDEX

## N

|                      |    |
|----------------------|----|
| NC-0208[SET]         | 65 |
| NC-0415 KIT          | 18 |
| NC-0425 KIT          | 18 |
| NC-0615 KIT          | 18 |
| NC-2210N[SET]        | 65 |
| NC-3210              | 10 |
| NC-3231Q             | 10 |
| NC-3410              | 10 |
| NC-3610Q             | 10 |
| NC-3810              | 10 |
| NC-3812              | 10 |
| NC-3831              | 10 |
| NC-3910              | 10 |
| NC-3911              | 11 |
| NC-398               | 11 |
| NC-4117              | 11 |
| NC-4130              | 11 |
| NC-4210              | 11 |
| NC-4210N             | 11 |
| NC-4213/4223         | 11 |
| NC-4217              | 11 |
| NC-4230              | 11 |
| NC-4230Q             | 11 |
| NC-4232Q             | 12 |
| NC-4232Q KIT         | 18 |
| NC-4233Q             | 12 |
| NC-4233Q KIT         | 18 |
| NC-4233QH            | 12 |
| NC-4233TL            | 12 |
| NC-4236              | 12 |
| NC-4236Q             | 12 |
| NC-4240              | 11 |
| NC-4255PVC           | 12 |
| NC-4255Q             | 12 |
| NC-4255Q KIT         | 18 |
| NC-4255Q-41KIT       | 18 |
| NC-4255Q-41KIT / A05 | 18 |
| NC-4255QH            | 12 |
| NC-4255QP            | 12 |
| NC-4256              | 12 |
| NC-4256Q             | 12 |
| NC-4256Q-2           | 12 |
| NC-4258              | 13 |
| NC-4265Q             | 19 |
| NC-4277Q             | 13 |
| NC-4299Q             | 13 |
| NC-4600              | 13 |
| NC-4600-14Kit        | 19 |
| NC-4600-KIT          | 19 |
| NC-4610              | 13 |
| NC-4610N             | 13 |
| NC-4610Q             | 13 |
| NC-4630              | 13 |
| NC-4630Q             | 13 |
| NC-4650              | 13 |
| NC-4650 KIT          | 19 |
| NC-4650H             | 13 |
| NC-4670Q             | 19 |
| NC-4811              | 13 |
| NC-498               | 13 |
| NC-6113/6123         | 14 |
| NC-6201              | 14 |
| NC-6210Q             | 14 |
| NC-6215/6225         | 14 |
| NC-6216/6226         | 14 |
| NC-6217              | 14 |

## N

|                      |     |
|----------------------|-----|
| NC-6218              | 14  |
| NC-6218-6            | 14  |
| NC-6233Q             | 14  |
| NC-6236              | 15  |
| NC-6236 KIT          | 19  |
| NC-6236Q             | 15  |
| NC-6236Q KIT         | 19  |
| NC-6255Q             | 15  |
| NC-6255Q KIT         | 19  |
| NC-6255QH            | 15  |
| NC-6256Q             | 15  |
| NC-6266              | 15  |
| NC-6266-6            | 15  |
| NC-6266H             | 15  |
| NC-8211/8221         | 15  |
| NC-8212              | 15  |
| NC-8216/8226         | 15  |
| NC-8217              | 16  |
| NC-8219              | 16  |
| NC-8226Q             | 15  |
| NC-8232              | 16  |
| NC-8237/NC-8237-6    | 16  |
| NC-8242/NC-8242-8    | 16  |
| NC-8252/8262         | 16  |
| NC-8260              | 16  |
| NC-8260-6            | 16  |
| NC-8266P             | 16  |
| NC-8266P-6           | 16  |
| NC-8266S             | 16  |
| NC-8266S-6           | 16  |
| NC-8266S-8           | 16  |
| NC-8311/8351         | 16  |
| NC-8322/8342         | 16  |
| NC-8331              | 16  |
| NC-8331-6            | 16  |
| NC-8332X             | 17  |
| NC-8332X-6           | 17  |
| NC-8343              | 17  |
| NC-8343-8            | 17  |
| NC-8362/8372         | 17  |
| NC-8382/NC-8382-8    | 17  |
| NC-9223/9243         | 17  |
| NC-REPAIR KIT        | 109 |
| NE-0357              | 23  |
| NE-0405 KIT          | 23  |
| NE-0413/NE-0413S KIT | 23  |
| NE-251               | 20  |
| NE-251R              | 20  |
| NE-261               | 20  |
| NE-2803              | 20  |
| NE-2900              | 23  |
| NE-2905              | 20  |
| NE-321               | 20  |
| NE-3305              | 20  |
| NE-3310              | 20  |
| NE-332               | 20  |
| NE-332T              | 20  |
| NE-343               | 20  |
| NE-351               | 20  |
| NE-351R              | 20  |
| NE-352               | 21  |
| NE-361               | 20  |
| NE-362               | 21  |
| NE-3803              | 20  |
| NE-3808              | 21  |
| NE-383               | 21  |

## N

|               |     |
|---------------|-----|
| NE-3900       | 23  |
| NE-3901       | 21  |
| NE-399        | 22  |
| NE-421        | 20  |
| NE-4305       | 20  |
| NE-4310       | 20  |
| NE-432        | 20  |
| NE-432T       | 20  |
| NE-443        | 20  |
| NE-451        | 20  |
| NE-451R       | 20  |
| NE-462        | 22  |
| NE-462T       | 22  |
| NE-4808       | 21  |
| NE-4815       | 22  |
| NE-483        | 21  |
| NE-488        | 22  |
| NE-4901       | 21  |
| NE-499        | 22  |
| NE-499N       | 22  |
| NE-REPAIR KIT | 109 |

## P

|           |    |
|-----------|----|
| PA-111    | 58 |
| PA-201    | 58 |
| PA-201V   | 58 |
| PA-203N   | 58 |
| PA-211    | 58 |
| PA-211TS  | 59 |
| PA-301    | 58 |
| PA-301D   | 58 |
| PA-301L   | 58 |
| PA-301V   | 58 |
| PA-312V   | 58 |
| PA-321    | 58 |
| PA48PB06T | 60 |
| PA-9048   | 60 |
| PA-9048P  | 60 |
| PA-9048PT | 60 |
| PA-9064   | 60 |
| PA-9064P  | 60 |
| PA-MC     | 58 |
| PB-1305   | 59 |
| PB-1308   | 59 |
| PB-1310   | 59 |
| PB-1312   | 59 |
| PB-2402   | 59 |
| PB-2601   | 59 |
| PB-9006   | 60 |
| PB-9006P  | 60 |
| PB-9006PT | 60 |
| PB-9010   | 60 |
| PB-9010P  | 60 |
| PC-2010   | 41 |
| PC-901    | 41 |
| PE-MC     | 58 |
| PN-150    | 41 |
| PN-180    | 41 |
| PN-250    | 41 |
| PN-280    | 41 |

## Q

|                     |    |
|---------------------|----|
| QA-0115 A/B[SET]    | 27 |
| QA-0207 A/B[SET]    | 27 |
| QA-0215 A/B[SET]    | 27 |
| QA-0615 A/B[SET]    | 27 |
| QA-101 A/B          | 24 |
| QA-110 A/B          | 24 |
| QA-111 A/B          | 24 |
| QA-116 A/B          | 24 |
| QA-1211/QA-1221 A/B | 24 |
| QA-131 A/B          | 24 |
| QA-141 A/B          | 24 |
| QA-141L A/B         | 24 |
| QA-143 A/B          | 24 |
| QA-151 A/B          | 24 |
| QA-163 A/B          | 24 |
| QA-163L A/B         | 24 |
| QA-1710 A/B         | 25 |
| QA-210 A/B          | 25 |
| QA-211 A/B          | 25 |
| QA-2211/QA-2221 A/B | 24 |
| QA-231Q A/B         | 25 |
| QA-241 A/B          | 25 |
| QA-311 A/B          | 26 |
| QA-313 A/B          | 26 |
| QA-315 A/B          | 26 |
| QA-412              | 28 |
| QA-421              | 28 |
| QA-431              | 28 |
| QA-432              | 28 |
| QA-441              | 28 |
| QA-4507             | 28 |
| QA-511              | 28 |
| QA-611 A/B          | 26 |
| QA-6205 A/B         | 26 |
| QA-632Q A/B         | 26 |
| QA-633Q A/B         | 26 |
| QA-651N[SET]        | 65 |
| QA-681 A/B          | 26 |
| QA-688              | 27 |
| QB-0618[SET]        | 65 |
| QB-0808             | 68 |
| QB-0808U            | 68 |
| QB-1004             | 29 |
| QB-104X/QB-105X     | 29 |
| QB-114X/QB-115X     | 29 |
| QB-117              | 29 |
| QB-124/125          | 29 |
| QB-134X             | 29 |
| QB-135X             | 29 |
| QB-144X             | 29 |
| QB-145X             | 29 |
| QB-154X             | 29 |
| QB-155X             | 29 |
| QB-164X             | 29 |
| QB-165X             | 29 |
| QB-177              | 29 |
| QB-179              | 29 |
| QB-185              | 30 |
| QB-187              | 30 |
| QB-192/QB-192L      | 30 |
| QB-193/QB-193L      | 30 |
| QB-194              | 30 |
| QB-194CN            | 30 |
| QB-194L             | 30 |
| QB-195-85/120       | 30 |
| QB-195CN            | 30 |

## Q

|                  |     |
|------------------|-----|
| QB-195L-85/120   | 30  |
| QB-197Q          | 30  |
| QB-199S/M        | 30  |
| QB-20203         | 34  |
| QB-2925          | 31  |
| QB-2925L         | 31  |
| QB-311           | 32  |
| QB-312           | 32  |
| QB-313           | 32  |
| QB-321           | 32  |
| QB-322           | 32  |
| QB-322C          | 32  |
| QB-322RC         | 32  |
| QB-324           | 32  |
| QB-325N [SET]    | 32  |
| QB-41            | 34  |
| QB-42            | 33  |
| QB-43            | 34  |
| QB-45            | 34  |
| QB-46            | 33  |
| QB-47            | 34  |
| QB-48012         | 36  |
| QB-48111         | 36  |
| QB-48112         | 36  |
| QB-48211         | 36  |
| QB-48212         | 36  |
| QB-49602         | 33  |
| QB-51602         | 34  |
| QB-51612         | 34  |
| QB-52            | 33  |
| QB-53            | 34  |
| QB-54            | 34  |
| QB-55            | 33  |
| QB-56            | 34  |
| QB-57602         | 34  |
| QB-57642         | 35  |
| QB-58502/QB58602 | 33  |
| QB-58642/58542   | 35  |
| QB-59602         | 34  |
| QB-59642         | 35  |
| QB-623           | 30  |
| QB-7114 S/M      | 31  |
| QB-7115 S/M      | 31  |
| QB-7145 S/M      | 31  |
| QB-7215M         | 31  |
| QB-7245M         | 31  |
| QB-7315 S/M      | 31  |
| QB-801/9401      | 105 |
| QB-802           | 68  |
| QB-802T          | 68  |
| QB-802TU         | 68  |
| QB-802U          | 68  |
| QB-812           | 68  |
| QB-812T          | 68  |
| QB-812TU         | 68  |
| QB-812U          | 68  |
| QB-904           | 107 |
| QB-905           | 107 |
| QB-907           | 107 |
| QB-911[SET]      | 106 |
| QB-912[SET]      | 106 |
| QB-913           | 107 |
| QB-914           | 107 |
| QB-9211A/B[SET]  | 106 |
| QB-9213A/B[SET]  | 106 |
| QB-922/QB-923    | 104 |

## Q

|                   |     |
|-------------------|-----|
| QB-9302/QB-9303   | 104 |
| QB-9305/QB-9306   | 104 |
| QB-9303K04        | 111 |
| QB-9315/QB-9355   | 104 |
| QB-9316/QB-9356   | 104 |
| QB-9320           | 106 |
| QB-9323           | 106 |
| QB-9327/QB-9366   | 104 |
| QB-9337M/QB-9337S | 105 |
| QB-9345/QB-9346   | 104 |
| QB-94 Series      | 106 |
| QB-9400           | 68  |
| QB-9411           | 68  |
| QB-9412           | 68  |
| QB-9414           | 68  |
| QB-9415           | 68  |
| QB-9434           | 105 |
| QB-9434U          | 105 |
| QB-9444           | 105 |
| QB-9444U          | 105 |
| QB-9507           | 106 |
| QB-95 Series      | 106 |
| QB-9702           | 105 |
| QB-9703           | 105 |
| QB-9712K          | 104 |
| QB-9713K          | 104 |
| QB-9742K12        | 110 |
| QB-9742K20        | 110 |
| QB-9743K12        | 110 |
| QB-9743K20        | 111 |
| QB-974K12         | 111 |
| QB-9752K07        | 110 |
| QB-9762K07        | 110 |
| QB-9773K19        | 110 |
| QB-9802           | 104 |
| QB-9803           | 104 |
| QB-9933V          | 111 |
| QC-213            | 38  |
| QC-213T           | 38  |
| QC-234            | 38  |
| QC-234T           | 38  |
| QC-253            | 38  |
| QC-254            | 38  |
| QC-264            | 38  |
| QC-333            | 38  |
| QC-512            | 37  |
| QD-221            | 39  |
| QD-230            | 39  |
| QD-242            | 39  |
| QD-260            | 39  |
| QD-291N           | 39  |
| QD-321            | 39  |
| QD-501            | 39  |
| QD-905P           | 107 |
| QD-906P           | 107 |
| QD-924P           | 107 |
| QD-932P           | 107 |
| QE-2130           | 42  |
| QE-2133           | 42  |
| QE-2137           | 42  |
| QE-2143           | 42  |
| QE-231            | 41  |
| QE-323N           | 66  |
| QE-324            | 42  |
| QE-331            | 42  |
| QE-332            | 42  |

## Q

|                  |     |
|------------------|-----|
| QE-333           | 42  |
| QE-334           | 42  |
| QE-341           | 44  |
| QE-342           | 44  |
| QE-343           | 44  |
| QE-344           | 44  |
| QE-431           | 42  |
| QE-432           | 42  |
| QE-433           | 42  |
| QE-434           | 42  |
| QE-441           | 44  |
| QE-442           | 44  |
| QE-443           | 44  |
| QE-532           | 42  |
| QE-533           | 43  |
| QE-542           | 44  |
| QE-543           | 44  |
| QE-6010/QE-6010L | 46  |
| QE-6011/QE-6011L | 47  |
| QE-6012/QE-6012L | 47  |
| QE-6020/QE-6020L | 46  |
| QE-6021/QE-6021L | 47  |
| QE-6022/QE-6022L | 47  |
| QE-6030/QE-6030L | 46  |
| QE-6110/QE-6110L | 46  |
| QE-6111/QE-6111L | 47  |
| QE-6112/QE-6112L | 47  |
| QE-6120/QE-6120L | 46  |
| QE-6121/QE-6121L | 47  |
| QE-6122/QE-6122L | 47  |
| QE-6130/QE-6130L | 46  |
| QE-624           | 45  |
| QE-624QA[SET]    | 45  |
| QE-633           | 43  |
| QE-634           | 43  |
| QE-831           | 43  |
| QE-833           | 43  |
| QE-841           | 44  |
| QE-843           | 44  |
| QE-845           | 44  |
| QE-924           | 45  |
| QE-933           | 43  |
| QE-935           | 43  |
| QE-936           | 43  |
| QG-102           | 40  |
| QG-103           | 40  |
| QG-202           | 40  |
| QK-111           | 40  |
| QK-111T          | 40  |
| QK-112 / QK-112N | 40  |
| QK-121           | 40  |
| QK-131           | 40  |
| QK-901           | 40  |
| QK-902           | 40  |
| QK-903           | 40  |
| QK-904           | 40  |
| QK-SERIES        | 109 |
| QM-1125          | 69  |
| QM-901           | 107 |
| QP-111           | 37  |
| QP-113           | 37  |
| QP-123           | 37  |
| QP-123QP         | 37  |
| QP-212N[SET]     | 66  |
| QP-213N[SET]     | 66  |
| QP-215           | 37  |

## Q

|            |    |
|------------|----|
| QP-223N    | 66 |
| QP-307 S/M | 67 |
| QP-317     | 67 |
| QP-327 S/M | 67 |
| QP-335     | 67 |
| QP-415     | 67 |
| QT-102     | 66 |
| QT-103     | 67 |
| QT-112T    | 37 |
| QT-203/113 | 37 |
| QT-203T    | 37 |
| QT-303     | 37 |

## R

|             |    |
|-------------|----|
| RA-101/101C | 49 |
| RA-102      | 49 |
| RA-105      | 49 |
| RA-110      | 49 |
| RA-111      | 11 |
| RA-1131     | 49 |
| RA-1132     | 51 |
| RA-1141     | 49 |
| RA-1142     | 51 |
| RA-1151     | 49 |
| RA-1162     | 51 |
| RA-1232     | 49 |
| RA-1242     | 49 |
| RA-1272     | 50 |
| RA-201      | 50 |
| RA-2161     | 49 |
| RA-2242     | 50 |
| RA-2272     | 50 |
| RA-301      | 51 |
| RA-30SERIES | 52 |
| RA-302      | 51 |
| RA-31SERIES | 52 |
| RA-40SERIES | 52 |
| RA-402      | 52 |
| RA-41SERIES | 52 |
| RA-50SERIES | 52 |
| RA-505N     | 67 |
| RA-51SERIES | 52 |
| RA-606      | 50 |
| RA-608      | 50 |
| RA-801      | 51 |
| RA-801ET    | 49 |
| RA-802      | 51 |
| RA-811      | 52 |

# ALPHABETIC INDEX

## S

|                 |     |
|-----------------|-----|
| SA-2015         | 75  |
| SA-3215/SA-3315 | 75  |
| SA-4320         | 75  |
| SB-201          | 69  |
| SB-2031         | 69  |
| SB-2131         | 69  |
| SB-215          | 69  |
| SB-3030         | 69  |
| SB-3038         | 69  |
| SB-3130         | 69  |
| SB-4031         | 69  |
| SB-4151         | 69  |
| SB-422          | 69  |
| SB-423          | 69  |
| SB-501          | 69  |
| SB-710          | 69  |
| SB-902          | 108 |
| SB-912          | 108 |
| SC-005          | 70  |
| SC-0320         | 71  |
| SC-05C[SET]     | 54  |
| SC-06C[SET]     | 54  |
| SC-211C         | 54  |
| SC-221C         | 54  |
| SC-212C         | 54  |
| SC-222C         | 54  |
| SC-2A/2B        | 108 |
| SC-331C         | 54  |
| SC-332C         | 54  |
| SC-33C/34C      | 54  |
| SC-341C         | 54  |
| SC-342C         | 54  |
| SC-371          | 54  |
| SC-371C         | 54  |
| SC-415P/SC-425P | 110 |
| SD-22           | 75  |
| SD-23           | 75  |
| SD-24           | 75  |
| SE-1001         | 117 |
| SE-1025         | 71  |
| SE-1101         | 71  |
| SE-2012         | 71  |
| SE-3001         | 71  |
| SF-306          | 103 |
| SF-604          | 103 |
| SF-605          | 103 |
| SG-101          | 109 |
| SG-400/500      | 63  |
| SG-400C         | 63  |
| SG-401/501      | 63  |
| SG-405          | 63  |
| SG-407          | 63  |
| SG-902          | 63  |
| SG-910          | 63  |
| SG-910S         | 63  |
| SG-911          | 63  |
| SG-912          | 63  |
| SG-912L         | 63  |
| SH-1001         | 103 |
| SJ-1650T        | 61  |
| SJ-1830F        | 61  |
| SJ-1850F        | 61  |
| SJ-BNF1664      | 61  |
| SJ-C1830F       | 61  |
| SJ-CN55         | 62  |
| SJ-CN57         | 62  |

## S

|               |     |
|---------------|-----|
| SJ-CN65       | 62  |
| SJ-CN70       | 62  |
| SJ-CN90       | 62  |
| SJ-FN90E      | 61  |
| SJ-TN64       | 61  |
| SK-1010       | 67  |
| SK-1131       | 67  |
| SM-0503       | 70  |
| SM-0813       | 70  |
| SM-0901/02/03 | 70  |
| SM-111R       | 68  |
| SN-1032       | 54  |
| SN-124/SN-268 | 109 |
| SN-128/SN-288 | 109 |
| SN-1268       | 56  |
| SN-1288       | 56  |
| SN-1368       | 56  |
| SN-2110       | 56  |
| SN-2124       | 56  |
| SN-2128       | 56  |
| SN-31 series  | 55  |
| SN-32 series  | 55  |
| SN-9101       | 54  |
| SN-9103       | 54  |
| SN-9201       | 54  |
| SN-9203       | 54  |
| SO-10         | 109 |
| SO-10T        | 109 |
| SP-101        | 53  |
| SP-102        | 53  |
| SP-103        | 53  |
| SP-104        | 53  |
| SP-105        | 53  |
| SP-111        | 53  |
| SP-112        | 53  |
| SP-113        | 53  |
| SP-212        | 53  |
| SP-213        | 53  |
| SP-3050       | 53  |
| SP-3070       | 53  |
| SP-3090       | 53  |
| SP-31050      | 53  |
| SP-31200      | 53  |
| SP-3150       | 53  |
| SP-3220       | 53  |
| SP-3300       | 53  |
| SP-3400       | 53  |
| SP-3500       | 53  |
| SP-3600       | 53  |
| SP-3700       | 53  |
| SP-3900       | 53  |
| SQ-0217       | 71  |
| SR-2001-KIT   | 70  |
| SR-2101       | 70  |
| ST-10C521     | 102 |
| ST-10C522S    | 102 |
| SU-8016       | 61  |
| SU-9025       | 61  |
| SU-9040       | 61  |
| SU-A3218S     | 62  |
| SU-A3222S     | 62  |
| SU-A3518S     | 62  |
| SU-A3522S     | 62  |
| SU-C1022J     | 61  |
| SU-C422J      | 61  |
| SU-H3218S     | 62  |

## S

|              |     |
|--------------|-----|
| SU-H3222S    | 62  |
| SU-H3518S    | 62  |
| SU-H3522S    | 62  |
| SV-1240      | 73  |
| SV-1260      | 73  |
| SV-1360      | 73  |
| SV-1460      | 73  |
| SV-1660      | 73  |
| SV-1860      | 73  |
| SV-2220      | 73  |
| SV-2260/2280 | 73  |
| SV-2360/2380 | 73  |
| SV-2431      | 73  |
| SV-2460      | 74  |
| SV-2660/2860 | 74  |
| SV-3260/3360 | 74  |
| SV-3460      | 74  |
| SV-3660/3860 | 74  |
| SW-12        | 74  |
| SW-13        | 74  |
| SX-1201      | 72  |
| SX-1615      | 72  |
| SX-1618      | 72  |
| SX-2101      | 72  |
| SX-3101      | 72  |
| SX-3102      | 72  |
| SX-3103      | 72  |
| SX-3111      | 72  |
| SX-3112      | 72  |
| SX-3202      | 72  |
| SX-3203      | 72  |
| SX-3301      | 72  |
| SX-4101      | 72  |
| SY-0213M     | 113 |
| SY-0223M     | 113 |
| SY-0233M     | 113 |
| SY-0313M     | 113 |
| SY-0323M     | 113 |
| SY-0333M     | 113 |
| SY-0413M     | 113 |
| SY-0423M     | 113 |
| SY-0433M     | 113 |
| SY-1213F     | 113 |
| SY-1223F     | 113 |
| SY-1233F     | 113 |
| SY-1313F     | 113 |
| SY-1323F     | 113 |
| SY-1333F     | 113 |
| SY-1413F     | 113 |
| SY-1423F     | 113 |
| SY-1433F     | 113 |
| SY-2001M     | 112 |
| SY-2002M     | 112 |
| SY-2011M     | 112 |
| SY-210F      | 112 |
| SY-210M      | 112 |
| SY-211F      | 112 |
| SY-211M      | 112 |
| SY-220F      | 112 |
| SY-220M      | 112 |
| SY-2213P     | 113 |
| SY-221F      | 112 |
| SY-221M      | 112 |
| SY-2223P     | 113 |
| SY-2233P     | 113 |
| SY-230F      | 112 |

## S

|          |     |
|----------|-----|
| SY-230M  | 112 |
| SY-2313P | 113 |
| SY-231F  | 112 |
| SY-231M  | 112 |
| SY-2323P | 113 |
| SY-2333P | 113 |
| SY-2413P | 113 |
| SY-2423P | 113 |
| SY-2433P | 113 |
| SY-251F  | 112 |
| SY-251M  | 112 |
| SY-3113H | 113 |
| SY-3123H | 113 |
| SY-3133H | 113 |
| SY-320F  | 112 |
| SY-320M  | 112 |
| SY-3213H | 113 |
| SY-321F  | 112 |
| SY-321M  | 112 |
| SY-3223H | 113 |
| SY-3233H | 113 |
| SY-3313H | 113 |
| SY-3323H | 113 |
| SY-3333H | 113 |
| SY-3413H | 113 |
| SY-3423H | 113 |
| SY-3433H | 113 |
| SY-351F  | 112 |
| SY-351M  | 112 |
| SZ-212A  | 109 |

## T

|            |    |
|------------|----|
| TB-205025N | 77 |
| TB-305025N | 77 |
| TB-320110N | 77 |
| TB-420210N | 77 |
| TB-450350N | 77 |
| TB-610060N | 77 |
| TB-615080N | 77 |
| TB-620100N | 77 |
| TD-202025  | 77 |
| TD-305050  | 77 |
| TD-410100  | 77 |
| TD-420200  | 77 |
| TD-610060  | 77 |
| TE-205025N | 76 |
| TE-225250N | 76 |
| TE-305025N | 76 |
| TE-320110N | 76 |
| TE-428210N | 76 |
| TE-442210N | 76 |
| TE-450350N | 76 |
| TE-81N     | 76 |
| TE-82N     | 76 |
| TE-83N     | 76 |
| TE-84N     | 76 |
| TE-85N     | 76 |
| TF-310080N | 78 |
| TF-430250N | 78 |
| TM-0416    | 76 |
| TM-0418    | 76 |

T

|            |    |
|------------|----|
| TM-0428-1  | 76 |
| TM-0428-2  | 76 |
| TM-0618    | 76 |
| TS-320100N | 78 |
| TS-440250N | 78 |
| TW-210222  | 76 |
| TW-310552  | 76 |
| TW-411102  | 76 |
| TW-412202  | 76 |
| TW-611602  | 77 |
| TW-611802  | 77 |
| TW-612102  | 77 |

W

|         |    |
|---------|----|
| WG-202N | 70 |
|---------|----|

Y

|         |     |
|---------|-----|
| YA-0303 | 117 |
|---------|-----|

Z

|         |     |
|---------|-----|
| ZB-211  | 117 |
| ZB-306  | 116 |
| ZB-307  | 116 |
| ZB-812  | 116 |
| ZB-814  | 116 |
| ZC-9156 | 116 |
| ZC-108  | 117 |
| ZC-111  | 117 |

Z

|          |     |
|----------|-----|
| ZC-112   | 117 |
| ZC-201R  | 116 |
| ZC-201B  | 116 |
| ZC-501   | 116 |
| ZC-202-1 | 116 |
| ZC-301   | 117 |
| ZC-302   | 117 |
| ZC-303   | 117 |
| ZC-304   | 117 |
| ZE-03    | 117 |
| ZF-01    | 117 |
| ZF-02    | 117 |
| ZH-104   | 117 |
| ZT-13-1  | 117 |
| ZT-13-2  | 103 |
| ZT-13-3  | 103 |
| ZT-31    | 52  |





**CORDLESS TOOLS**

# **CORDLESS TOOLS**



**CORDLESS TOOLS**

***SMALL . LIGHT . POWERFUL!***

# CORDLESS TOOLS

## NEW PRODUCT

### DRH-101 CORDLESS ROTARY HAMMER

5 pieces in one carton



Motor  
**BRUSHLESS**

### DRH-101A CORDLESS ROTARY HAMMER

2 pieces in one carton



Motor  
**BRUSHLESS**



| Item No. | Chuck Type | Impact Energy | Free Speed | Blows Per Minute | Max. Drilling Capacity |       |          | Net Weight |     |
|----------|------------|---------------|------------|------------------|------------------------|-------|----------|------------|-----|
|          |            |               | R.P.M      | B.P.M            | Wood                   | steel | Concrete | LBS        | kg  |
| DRH-101  | SDS Plus   | 2.6           | 1150       | 5100             | 30                     | 13    | 26       | 6.17       | 2.8 |

### DOM-101 CORDLESS OSCILLATING MULTIT-TOOL

6 pieces in one carton



Motor  
**BRUSHLESS**

### DOM-101A CORDLESS OSCILLATING MULTIT-TOOL

3 pieces in one carton



Motor  
**BRUSHLESS**



| Item No. | Minimum Oscillations | Maximum Oscillations | Oscillation Angle | Tool Length | Net Weight |      |
|----------|----------------------|----------------------|-------------------|-------------|------------|------|
|          | per minute           | per minute           | B.P.M             | mm          | LBS        | kg   |
| DOM-101  | 11000                | 18000                | 1.8°              | 320         | 2.29       | 1.04 |

### DR-102 CORDLESS RIVET GUN

10 pieces in one carton



Motor  
**BRUSHLESS**

### DR-102A CORDLESS RIVET GUN

3 pieces in one carton



Motor  
**BRUSHLESS**



| Item No. | Traction Power | Stroke Length | Capacity | Battery   | Rating Voltage | Completely Charged | Tool Length | Weight |
|----------|----------------|---------------|----------|-----------|----------------|--------------------|-------------|--------|
|          | lb-f / kg-f    | mm            | mm       | Li-ion Ah | V              | V                  | mm          | kg     |
| DR-102   | 4496 / 2040    | 27            | 2.4-6.4  | 5.0       | 18             | 20                 | 320         | 1.63   |

## DGG-102

### CORDLESS GREASE GUN

6 pieces in one carton



## DGG-102A

### CORDLESS GREASE GUN

3 pieces in one carton



| Item No. | Working Pressure | Grease Output | Capacity | Battery   | Rating voltage | Completely charged | Net Weight |     |
|----------|------------------|---------------|----------|-----------|----------------|--------------------|------------|-----|
|          | PSI              | ml            | g        | Li-ion Ah | V              | V                  | LBS        | kg  |
| DGG-102  | 7000             | 94.6          | 400      | 5.0       | 18             | 20                 | 5.3        | 2.4 |

## DHG-101

### CORDLESS HEAT GUN

8 pieces in one carton



| Item No. | Max Temperature | Airflow | Battery   | Rating voltage | Completely charged | Net Weight |      |
|----------|-----------------|---------|-----------|----------------|--------------------|------------|------|
|          | °c              | L/min   | Li-ion Ah | V              | V                  | LBS        | kg   |
| DHG-101  | 550 °c          | 200     | 5.0       | 18             | 20                 | 1.38       | 0.63 |

## DPW-101

### CORDLESS PRESSURE WASHER GUN

4 pieces in one carton



| Item No. | Flow Rate | Hose Length | Maximum Pressure | Tool Length | Rating voltage | Completely charged | Net Weight |
|----------|-----------|-------------|------------------|-------------|----------------|--------------------|------------|
|          | L/min     | m           | PSI(bar)         | mm          | V              | V                  | kg         |
| DPW-101  | 2.8       | 4           | 360(25)          | 876         | 18             | 20                 | 1.72       |

# CORDLESS TOOLS

## DW-404

CORDLESS IMPACT WRENCH

10 pieces in one carton



Motor  
**BRUSHLESS**



## DW-404A/DW-404K

CORDLESS IMPACT WRENCH

4 pieces in one carton



Motor  
**BRUSHLESS**



DW-404A



DW-404K



| Item No. | Square Drive | Bolt Capacity | Max Torque |     | No Load Speed              |                             | Impact Rate | Rating Voltage | Completely Charged | Net Weight |
|----------|--------------|---------------|------------|-----|----------------------------|-----------------------------|-------------|----------------|--------------------|------------|
|          | Inch (mm)    |               | FT-LB      | Nm  | R.P.M                      |                             | V           | V              | kg                 |            |
| DW-404   | 1/2"(12.7)   | M6-M16        | 660        | 900 | 0-900/0-1400/0-1800/0-2200 | 0-1150/0-1700/0-2300/0-2500 | 18          | 20             | 1.16               |            |

## DW-406

CORDLESS IMPACT WRENCH

6 pieces in one carton



Motor  
**BRUSHLESS**



## DW-406A

CORDLESS IMPACT WRENCH

3 pieces in one carton



Motor  
**BRUSHLESS**



| Item No. | Square Drive | Bolt Capacity | Max Torque |      | No Load Speed        |                      | Impact Rate | Rating Voltage | Completely Charged | Net Weight |
|----------|--------------|---------------|------------|------|----------------------|----------------------|-------------|----------------|--------------------|------------|
|          | Inch (mm)    |               | FT-LB      | Nm   | R.P.M                |                      | V           | V              | kg                 |            |
| DW-406   | 1/2"(12.7)   | M10-M25       | 1200       | 1600 | 0-1400/0-1900/0-2400 | 0-1800/0-2200/0-2800 | 18          | 20             | 2.0                |            |

**DW-601**  
CORDLESS IMPACT WRENCH  
3 pieces in one carton

**1900 Nm**

**Patented**  
Shock Absorption Body



**DW-601A[KIT]**  
CORDLESS IMPACT WRENCH  
2 pieces in one carton

- Contents :
- Accessory : 2pcs 5.0Ah Li-ion battery + 1pc charger



**DW-401**  
CORDLESS IMPACT WRENCH  
4 pieces in one carton

**3 AUTO STOP MODE**



**DW-401A[KIT]**  
CORDLESS IMPACT WRENCH  
3 pieces in one carton

- Contents :
- Accessory : 2pcs 5.0Ah Li-ion battery + 1pc charger



**DW-402**  
CORDLESS IMPACT WRENCH  
3 pieces in one carton



**DW-402A[KIT]**  
CORDLESS IMPACT WRENCH  
2 pieces in one carton

- Contents :
- Accessory : 2pcs 5.0Ah Li-ion battery+ 1pc charger
- Package : BMC



| Item No. | Square Drive | Bolt Capacity | Max Torque |      | No Load Speed        | Impact Rate          | Net Weight |      |
|----------|--------------|---------------|------------|------|----------------------|----------------------|------------|------|
|          | Inch (mm)    |               | FT-LB      | Nm   | R.P.M                | ipm                  | LBS        | kg   |
| DW-601   | 3/4"(19)     | M10-M27       | 1400       | 1900 | 0-900/0-1000/0-1800  | 0-1800/0-2000/0-2200 | 7.4        | 3.37 |
| DW-401   | 1/2"(12.7)   | M6-M16        | 600        | 813  | 0-1100/0-1600/0-2200 | 0-1500/0-2500/0-3000 | 3.3        | 1.48 |
| DW-402   | 1/2"(12.7)   | M10-M24       | 1250       | 1700 | 0-900/0-1000/0-1700  | 0-1800/0-2000/0-2200 | 7.27       | 3.33 |

# CORDLESS TOOLS

CORDLESS TOOLS



## DD-101 CORDLESS DRILL DRIVER

3 pieces in one carton

Note : This tool is attached an auxiliary handle



Motor  
**BRUSHLESS**

## DD-101A CORDLESS DRILL DRIVER

2 pieces in one carton

- Contents :
- 2pcs 18V 5.0 Ah Lithium-ion
- 1pc Lithium-ion Battery Charger
- 1pc Auxiliary Handle



Motor  
**BRUSHLESS**



## DH-101 CORDLESS HAMMER DRILL DRIVER

3 pieces in one carton



Motor  
**BRUSHLESS**

## DH-101A CORDLESS HAMMER DRILL DRIVER

2 pieces in one carton

- Contents :
- 2pcs 18V 5.0 Ah Lithium-ion
- 1pc Lithium-ion Battery Charger



Motor  
**BRUSHLESS**

| Item No. | Chuck Size | Max Torque | No Load Speed         | Impact Rate    | Torque Setting | Max Drill Capacity |              | Net Weight |      |
|----------|------------|------------|-----------------------|----------------|----------------|--------------------|--------------|------------|------|
|          | mm         | Nm         | R.P.M                 | ipm            | —              | Wood               | Steel        | LBS        | kg   |
|          |            |            |                       |                |                | <b>Wood</b>        | <b>steel</b> |            |      |
| DD-101   | 1/2"(13)   | 90         | Low 0-500/High 0-2000 | ---            | 23+1           | 50                 | 13           | 3.02       | 1.37 |
| DH-101   | 1/2"(13)   | 90         | Low 0-500/High 0-2000 | 0-8000/0-32000 | 23+1+1         | 60                 | 13           | 3.19       | 1.45 |

## DRS-101

### CORDLESS RECIPROCATING SAW

3 pieces in one carton



## DRS-102

### CORDLESS RECIPROCATING SAW

3 pieces in one carton



## DJS-101

### CORDLESS JIG SAW

3 pieces in one carton



SUITABLE FOR BOTH T & U SHANK

## DRS-101A[KIT]

### CORDLESS RECIPROCATING SAW

3 pieces in one carton



## DRS-102A[KIT]

### CORDLESS RECIPROCATING SAW

3 pieces in one carton



## DJS-101A[KIT]

### CORDLESS JIG SAW

3 pieces in one carton



| Item No. | Stroke Length | Stroke Per min. | Overall Length | Cut Capacity |                 |              | Net Weight |      |
|----------|---------------|-----------------|----------------|--------------|-----------------|--------------|------------|------|
|          | mm            | S.P.M           | inch(mm)       | mm           | mm              | mm           | LBS        | kg   |
|          |               | <b>S.P.M</b>    |                | <b>Wood</b>  | <b>aluminum</b> | <b>steel</b> |            |      |
| DRS-101  | 29            | 3100            | 16-1/7"(410)   | 200          | ---             | 20           | 5.95       | 2.7  |
| DRS-102  | 25            | 3100            | 13-3/13"(335)  | 160          | ---             | 16           | 3.92       | 1.78 |
| DJS-101  | 25            | 2200            | 16-1/7"(410)   | 2-1/2"(63)   | 3/8"(9.53)      | 1/4"(6)      | 5.9        | 2.7  |

## DCS-101

### CORDLESS CIRCULAR SAW

2 pieces in one carton



## DCS-101A[KIT]

### CORDLESS CIRCULAR SAW

2 pieces in one carton



| Item No. | Blade Arbor Size | Blade Dia   | No Load Speed | Cutting Capacity |            | Bevel Capacity | Overall Length | Net Weight |      |
|----------|------------------|-------------|---------------|------------------|------------|----------------|----------------|------------|------|
|          | Inch(mm)         | Inch(mm)    | R.P.M         | Inch(mm)         | Inch(mm)   | Degree         | Inch(mm)       | LBS        | kg   |
|          |                  |             |               | <b>90°</b>       | <b>45°</b> |                |                |            |      |
| DCS-101  | 16               | 7-1/4"(185) | 4500          | 2-3/8"(60.5)     | 1-3/4"(46) | 0-65°          | 13-3/8"(340)   | 7.51       | 3.41 |



# CORDLESS TOOLS

## DG-501 CORDLESS ANGLE GRINDER

6 pieces in one carton

Note : The grinding wheel is not supplied along with the tool



## DG-585 CORDLESS ANGLE GRINDER

10 pieces in one carton

Note : The grinding wheel is not supplied along with the tool



## DG-501A[KIT] CORDLESS ANGLE GRINDER

2 pieces in one carton

- Contents :
- 2pcs 18V 5.0 Ah Lithium-ion
- 1pc Lithium-ion Battery Charger
- Note : The grinding wheel is not supplied along with the tool



## DG-585502A[KIT] CORDLESS ANGLE GRINDER

2 pieces in one carton

- Accessories :
- 5.0Ah battery x 2pcs
- Charger x 1pc
- Guard spanner x 1pc
- Aux handle x 1pc
- Note : The grinding wheel is not supplied along with the tool



## DOS-501 CORDLESS RANDOM ORBITAL SANDER

2 pieces in one carton



## DOS-501A[KIT] CORDLESS RANDOM ORBITAL SANDER

2 pieces in one carton

- Contents :
- 2pcs 18V 5.0 Ah Lithium-ion
- 1pc Lithium-ion Battery Charger
- Packaging : Color Box



| Item No. | Stroke Size | Pad Dia  | Orbit | Free Speed | Overall Length | Net Weight |      |
|----------|-------------|----------|-------|------------|----------------|------------|------|
|          |             | inch(mm) |       | R.P.M      | inch(mm)       | LBS        | kg   |
|          |             |          |       |            |                |            |      |
| DG-501   | M14 x P2.0  | 5"(125)  | ---   | 8000       | 12-9/16"(320)  | 3.25       | 1.48 |
| DG-585   | M14 x P2.0  | 5"(125)  | ---   | 8000       | 11-7/32"(285)  | 4.8        | 2.2  |
| DOS-501  | ---         | 5"(125)  | 3.0   | 7000-11000 | 11-13/16"(300) | 2.7        | 1.23 |



## DS-10202A

### CORDLESS IMPACT DRIVER

5 pieces in one carton



- Max. torque 100 NM
- Quick charge-up in 30 minutes
- Battery x 2pcs included for a longer period of usage
- LED lamp to light up the working area
- Battery applicable to all m7 10.8V cordless models



## DS-201

### CORDLESS IMPACT DRIVER

4 pieces in one carton

**3** AUTO STOP MODE



Motor **BRUSHLESS**

## DS-201A[KIT]

### CORDLESS IMPACT DRIVER

3 pieces in one carton

- Contents :
- 2pcs 18V 5.0 Ah Lithium-ion
- 1pc Lithium-ion Battery Charger



Motor **BRUSHLESS**



| Item No. | Chuck Size | Bolt Capacity | Max Torque |     | No Load Speed        | Impact Rate          | Battery   | Net Weight |      |
|----------|------------|---------------|------------|-----|----------------------|----------------------|-----------|------------|------|
|          | Inch (mm)  |               | FT-LB      | Nm  | R.P.M                | ipm                  | Li-ion Ah | LBS        | kg   |
| DS-10202 | 1/4"(6.35) | M4-M12        | 74         | 100 | 0-2200               | 0-3000               | 2.0       | 2.2        | 1.0  |
| DS-201   | 1/4"(6.35) | M12           | 150        | 203 | 0-1100/0-1900/0-2800 | 0-1200/0-2350/0-3300 | 5.0       | 2.8        | 1.28 |

# CORDLESS TOOLS

# CORDLESS TOOLS



## DW-1840 CORDLESS IMPACT WRENCH

5 pieces in one carton



## DW-18502A[KIT] CORDLESS IMPACT WRENCH

3 pieces in one carton

- Contents :
- 2pcs 18V 5.0 Ah Lithium-ion
- 1pc Lithium-ion Battery Charger



| Item No. | Square Drive | Bolt Capacity | Max Torque |      | No Load Speed | Impact Rate | Battery   | Net Weight |     |
|----------|--------------|---------------|------------|------|---------------|-------------|-----------|------------|-----|
|          | Inch (mm)    |               | FT-LB      | Nm   | R.P.M         |             | Li-ion Ah | LBS        | kg  |
| DW-1840  | 1/2"(12.7)   | M6-M24        | 900        | 1220 | 0-1900        | 0-2200      | 5.0       | 7.0        | 3.2 |



**DFL-101**  
CORDLESS LED FLOOD LIGHT

4 pieces in one carton

- Key Spec :
- Bulb Type : LED
- Lumens : 180° 450 LM / 360° - Low 550 LM / 360° - High 850 LM
- Runtime : 180° 18 Hrs / 360° - Low 20 Hrs / 360° - High 10 Hrs



**DB-1850P**  
18V 5.0AH LI-ION BATTERY

20 pieces in one carton



**DB-1825**  
18V 2.5AH LI-ION BATTERY

20 pieces in one carton



**DC-18A**  
CORDLESS 18V BATTERY CHARGER

10 pieces in one carton

- 18V Li-ion Battery Charger
- ( For DB-1825/DB-1850/DB-1850P )





**CORDLESS TOOLS**

# **CORDLESS TOOLS**

*M7 Cordless 18V Battery Li-ion 5.0 Ah*



2024  
2025

**Cordless | Pneumatic Solutions**

CONSTRUCTION | CARPENTRY | AUTO MAINTENANCE | METAL WORK

